



## Access to energy

Solutions to simplify and secure  
electrical distribution

Catalogue  
Energy controlling

**MICHAUD**



# 60 YEARS EXPERTISE

**M**ICHAUD is a French industrial group specialised in energy distribution networks for more than 60 years.

MICHAUD Export, subsidiary dedicated to international markets, develops and sells solutions according to applicable standards thanks to its know-how as well as its relationships with local users.

-  60 Million €
-  + 70 countries
-  70 protected innovations yearly
-  10 locations
-  + 250 employees
-  + 8 000 references
-  10 million € stock value
-  20 million products leaving factories yearly

## PRESCRIPTION & DIAGNOSIS

A strong market understanding and a recognised technical knowledge to serve your projects in order to propose suitable solutions.

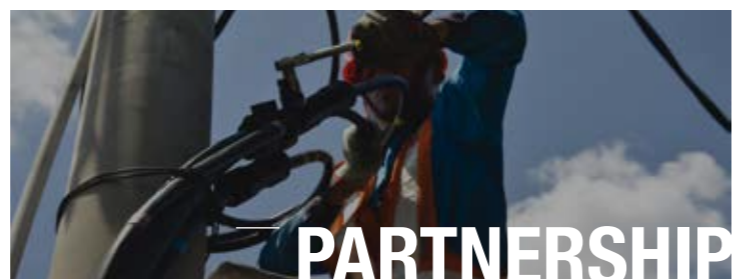

## INNOVATION & QUALITY

Investing near 8% of the turnover in R&D, we develop tomorrow's solutions and guarantee quality and reliability of products thanks to a COFRAC and ASEFA accredited and independent test laboratory (accreditation n°1-0579 / www.cofrac.fr).



## FITTERS TRAINING

As preferred technical partner, we encourage learning and knowledge transmission together with product commercialisation.



According to the international standards, Michaud Export designs and develops energy distribution solutions. The product range is focused on two fields of expertise:

- **Low Voltage Network:** to connect and protect the overhead and underground electrical lines ;
- **Energy Controlling:** to manage and offer easy access to electricity.



MICHAUD benefits from a privileged collaboration with many partners around the world. Thanks to an engineering Department dedicated to international business, MICHAUD provides support to Power Utilities in their grid expansion projects.

Besides, MICHAUD supports and works in partnership with power sector organizations.

## PRODUCTS BRANDS

**MICHAUD**  
HABITAT ET RÉSEAU ÉLECTRIQUE

**MIPROTEC**  
PROTECTION ET INSTALLATION





## Management

In Kenya, 85% of household customers account for 25% of energy sales. In these conditions, an economical and autonomous management system can improve profitability and encourage access to energy.

The **energy flat fee** invoicing simplifies customers management by lowering operating and maintenance costs.

For Income Generating Activities (IGAs), a solution with simplified metering enables to reduce purchase costs for the operator.

## Distribution

**Optimising** cable cross-sections for actual consumption is an effective way to lower the costs of a project.

With a 2x6mm<sup>2</sup> cable cross-section, 30A intensity and a reach of 40m, voltage drop is below 2%.

The 2x6mm<sup>2</sup> cable and corresponding accessories ensure implementation savings up to 30% for the operator.

## Protection

In a context where maintenance costs are very high on electrical networks, materials protection is one of the main way to guarantee the equipment **sustainability**.

The network head-end is a key point of a LV infrastructure. Michaud Export proposes an economical alternative technology using fuses. Their high breaking capacity guarantees the installation security.

In addition, electrical networks must be protected with earth systems for people and goods safety.

## Simplified management of the consumption

# SOLUTIONS FOR THE ENERGY MANAGEMENT

### Issues ?



In developing countries and more particularly in Sub-Saharan Africa the electrical network according to its infrastructure usually only reaches 20% of localities. This deficiency does not enable an **economic, and social development** of those territories.



Knowing about this context and being focused into electricity distribution toward the end customer, Michaud designed **innovative solutions to optimize connection and business management.**



Operating and selling difficulties of the electrical service in rural areas, sometimes isolated, have been integrated into a global thinking. That is why Michaud's innovations take into account **every components of the connection, from cable to customer interface**, through **solutions for consumption management.**

### Benefits ?

- + Support for economic development
- + Minimize implementation, maintenance operating costs
- + Simplify customers' management



## How does the flat fee invoicing system work ?

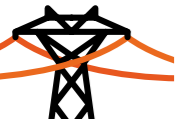

Operator:

- + Reliable and profitable business plan
- + Planned and regular incomes
- + Incomes collected before production
- + Anticipation of energy production
- + Automatic consumption management
- + Cancelled of meter reading costs
- + Easy to recover



End customer:

- + Monthly fixed cost
- + Flexible payments in agreement with the operator
- + Flat fee limited by time or energy quantity
- + Daily consumption management
- + Progressive awareness to energy management

## How does the payment operate ?

In the rural electrification context, end customer's payment management is one of the major difficulties. The flat fee system brings some **flexibility to the operator** by offering various possibilities for payments. According to the economic and social environment of connected villages, customers can pay:

- through **mobile banking solutions**
- through **money transfer solutions**
- with **fiduciary money**

Depending on the end customers number, payments can be settled using a classic IT spreadsheet, easy to manage.

## An adapted solution to rural electrification projects

With the **energy manager**, Michaud Export designed a solution which answers to this invoicing system. The energy manager can be set up according to the end customer contract and so frame the consumption.

The flat fee invoicing system remains the most suitable way for tiny consumptions.



The flat fee invoicing system allows the operator to collect incomes **before** engendering production costs.

- + Cash flows optimised
- + Limited recovery faults
- + Easy going investments and financing

## Financial advantage: better cash flows management

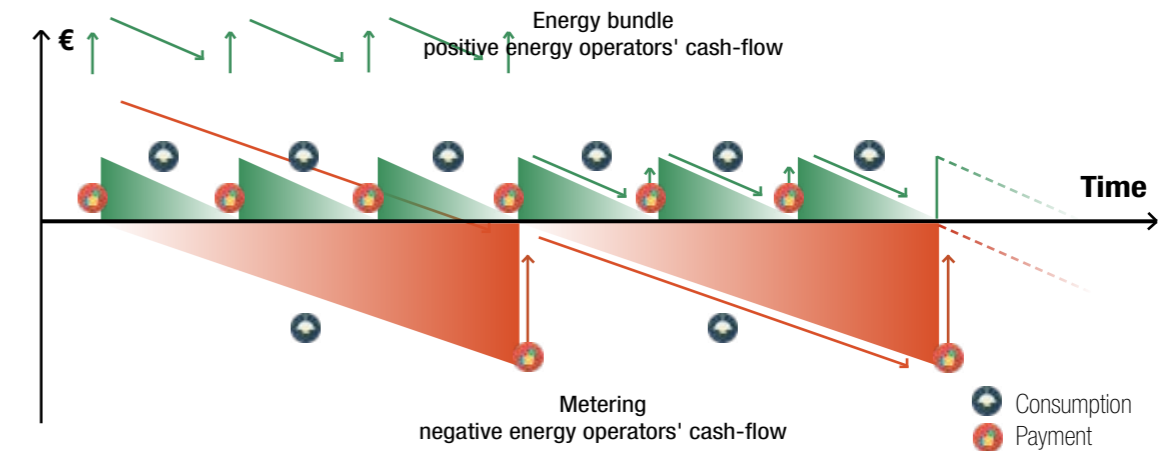

## Structural advantage: energy production anticipated

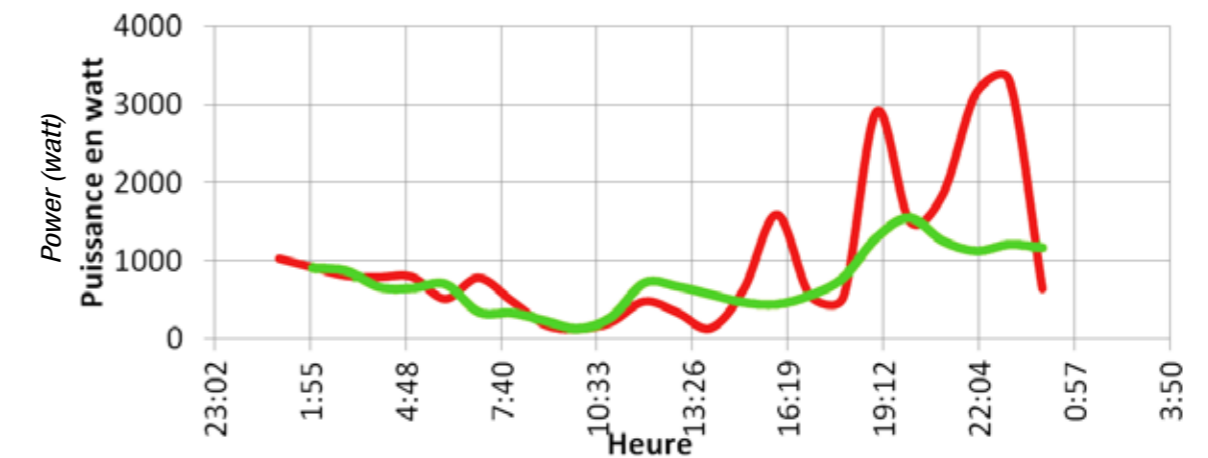

Daily consumption of a rural area village

— Before the energy managers installation — After the energy managers installation

Thanks to an electricity consumption ceiling, the flat fee system enables to know the end customers' maximum consumption. The operator **anticipates production needs** avoiding network failures and demand peaks.

The flat fee invoicing system tends to standardize inhabitants consumptions. It is a **didactic system**, perfectly suitable for end customers electrified for the first time.

## Energy manager



**K497**  
cabinet version



**K498**  
module version

### Application

The energy manager is provided with an electronic regulator, controlling power and managing energy automatically without user/operator intervention. It is perfectly suitable for flat fee energy invoicing. It replaces the meter and cancels the requirement of consumption reading. The cabinet can be installed outside thanks to the UV resistant IP34 property. It is designed for a single phase connection.

### Description

The energy manager is programmable according to the criterias chosen by the operator :

#### MANAGEMENT MODE



#### Time

Allocated time quantity is adjustable down to the last hour

#### Energy



Allocated energy quantity is adjustable down to the last watt

OR

#### SETTINGS



The energy manager setting can be performed on site

#### Power

Maximum instant power allowed (1500W.)

#### Transfer

Possibility to transfer the remaining time or energy quantity to the next period (1 period maximum)



#### Observation period

Period while allocated time or energy quantity is defined. This gives a daily or weekly control of the used energy (1 day to 1 week)



#### Shut down time after overage

Time during which energy is shutting down due to a power overage (up to 3600 seconds)



#### Accepted overage time

Time during which the maximum authorized instant power can be overcome (up to 60 seconds)

The energy manager is provided with 4 LED allowing to see the consumption progress through:

- an intuitive tracking method of colors
- the blinking LED speed

The settings can be modified according to flat fee contract set up by the operator, following households evolution.

Code	Designation	Weight (kg)	Sales unit
K497	PROGRAMMABLE ENERGY MANAGER CABINET 20 - 1 500W	0.360	1
K498	PROGRAMMABLE ENERGY MANAGER MODULE 20 - 1 500W	0.150	1

SEE SHEET  
Modular cabinets: make up your own solution



## Energy manager accessories

### Configuration

#### PC kit

The kit comprises an USB key containing the configuration software and an USB cable to connect energy manager to PC.

It is the best solution for the operator to set the energy manager at the office before the installation. Moreover, it allows to program the different flat fees levels offered by the operators.



K499



#### Application

The energy manager configuration is performed through a software available on PC or tablet.  
The last ten settings are kept in memory for a better subscriber follow up.

#### Tablet kit

The tablet kit includes a safe bluetooth system (dongle) and a digital tablet.

It allows an easy access to the energy manager on site.



K488



#### Option :

The EM (K487) bluetooth extension is available.  
Please enquire.



Code	Designation	Weight (kg)	Sales unit
K499	PC ENERGY MANAGER KIT	0.710	1
K488	PROGRAMMABLE ENERGY MANAGER BLUETOOTH DONGLE + TABLET	1.150	1

The connectors allow a safe phase and neutral connection thanks to a cutout function, protecting in this way the energy manager.

### Connection

#### Application

To afford the connection of a single customer as part of a new installation, the energy manager can be associated to connectors.

#### Description



K223



K232

	Fuse IPC (K223)	IPC (K232)
<b>Function</b>	It is designed to offer safe phase connection and protect both of the electrical installation and the energy manager against electrical faults.	It is designed to offer a watertight and safe connection of the neutral conductor.
<b>Technical specifications</b>	<ul style="list-style-type: none"> <li>- Cable sections: 16-95 / 1.5-16mm<sup>2</sup>.</li> <li>- Insulation piercing technology.</li> <li>- Simultaneous tightening.</li> <li>- Potential free shear head screw.</li> <li>- Very good resistance to harsh weather (humidity, heat...).</li> <li>- IP2x during implementation</li> <li>- IP33 after installation.</li> <li>- Integrated and sealable cutout.</li> <li>- Fuse: size 10.3x38mm gG.</li> </ul>	<ul style="list-style-type: none"> <li>- Cable sections: 16-95 / 2.5-35mm<sup>2</sup>.</li> <li>- Insulation piercing technology.</li> <li>- Simultaneous tightening.</li> <li>- Potential free shear head screw.</li> <li>- Very good resistance to harsh weather (humidity, heat...).</li> </ul>

Code	Designation	Weight (kg)	Sales unit
K223	FUSE CONNECTOR PIERCING 95/16	0.130	10
K232	CONNECTOR CBS / CT 95	0.130	30

For the fuses, **please enquire.**

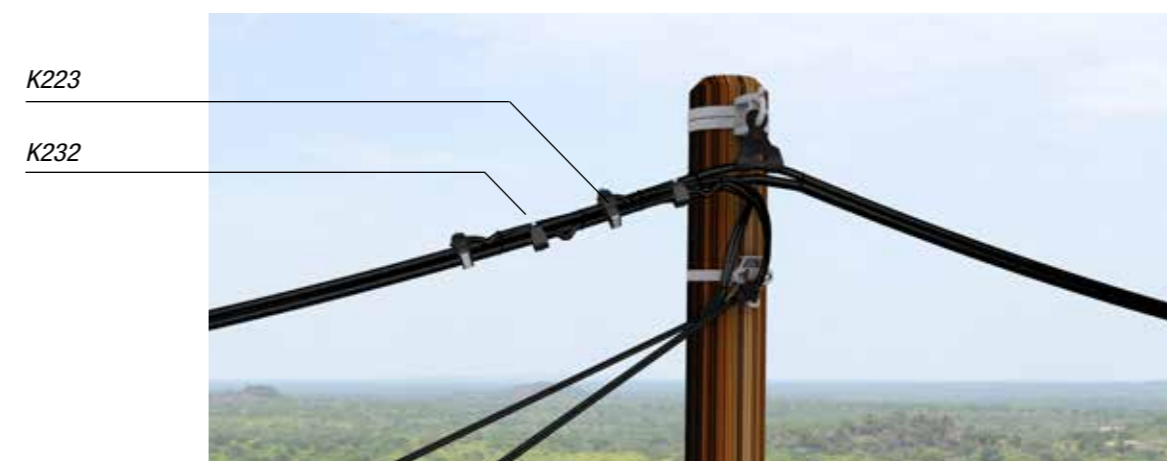

## Load limiter



Cabinet version



Module version

### Application

The load limiter is provided with an electronic regulator which controls intensity and manages power automatically without user/operator intervention.

It is perfectly suitable for flat fee invoicing. It replaces the meter and cancels the requirement of consumption reading.

The cabinet can be installed at the top of the pole or on the outside facade with the help of screws and strap. The cabinet resists to UV and to water or insect penetration (IP34D). Its cover closing can be sealed providing an excellent fraud protection.

This cabinet limiter can receive a single phase connection with 2.5-16mm<sup>2</sup> cable sections.

### Description

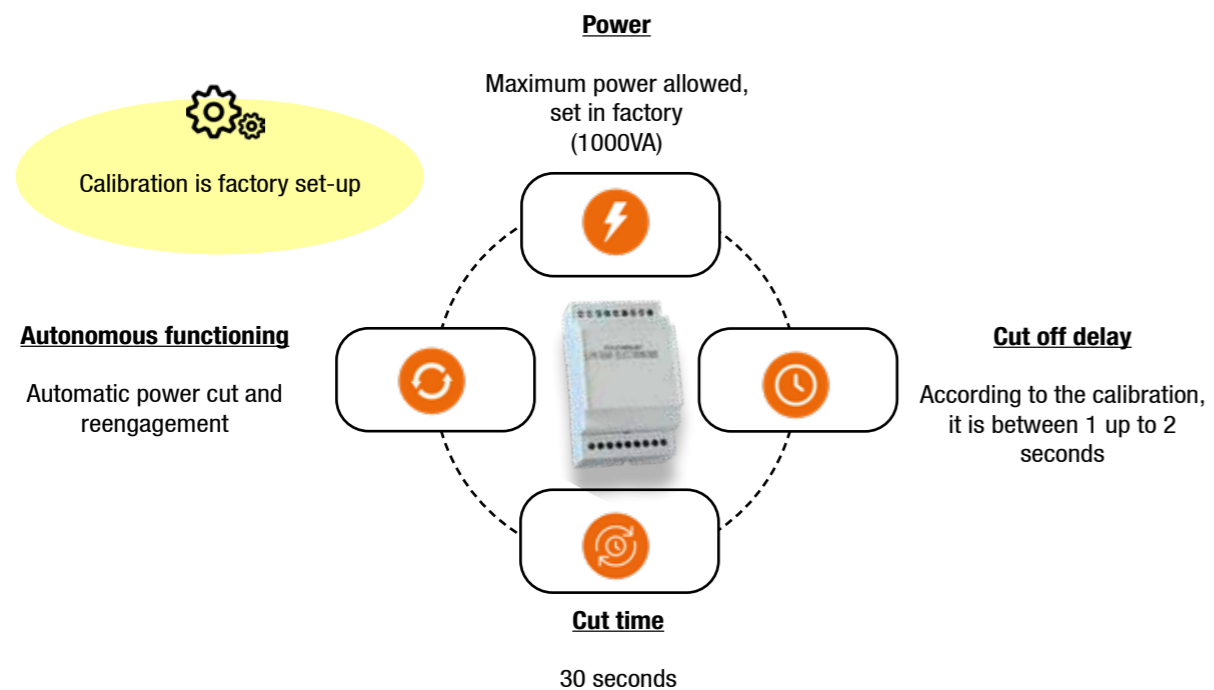

Code	Designation	Weight (kg)	Sales unit
K480	ELECTRONIC LIMITER CABINET 50-75VA	0.380	1
K481	ELECTRONIC LIMITER CABINET 75-250VA	0.380	1
K482	ELECTRONIC LIMITER CABINET 250-1000VA	0.380	1

## Integrated version into modular interface

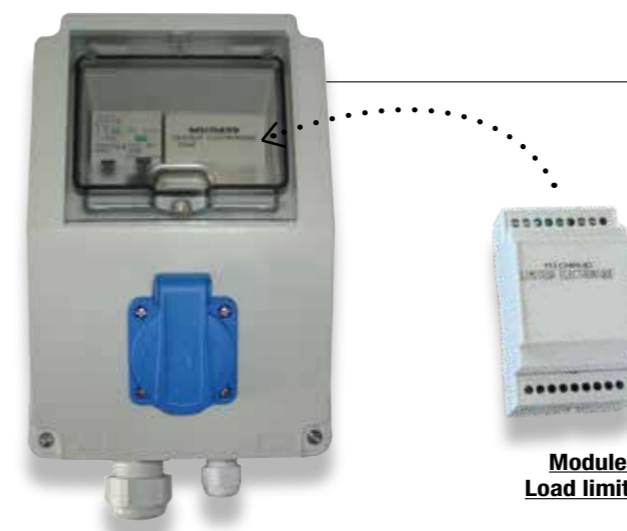

Module Load limiter

### Application

The load limiter module can be placed into an interface. It comprises a cutout and a differential circuit-breaker to ensure goods and people protection.

It is equipped with an input through a cable gland for power supply and 2 outputs :

- an electrical outlet for simple access to energy
- a second output through a cable gland and a insulating screw joint for home wiring.

The whole is pre wired and is suitable for a single-phase connection. Ideally, it can be installed inside the home or in an outdoor shelter.

### Description

#### Envelop:

- Synthetic materials.
- Dimensions (LxWxD): 220(260)x150x120mm.
- Mounted / connected: cutout 10.3x38 (hidden) / differential circuit-breaker / modular electronic load limiter / earthing terminal block / power socket and black domino terminal.
- Cable gland at the bottom used to route power cables (2x6-16mm<sup>2</sup> - diameter 13 up to 18mm).
- Movable window on the front side making the access to modular devices easier.
- First outlet with power socket having closed protection cover IP54
- Second outlet with cable gland allowing leading-out cable (2x2.5mm<sup>2</sup> - diameter 5 up to 10mm).
- IP43 device with conductors.
- Fitted with precuts at the bottom enabling the fixing of the envelope with screws, on every kind of material.
- Anti-fraud: sealing possibility preventing access to the live areas.

#### Cut out:

- Disconnection: Phase and Neutral.
- Equipped with a fuse 16A gG 10.3x38mm.
- Hidden cutout, inaccessible from the user.

#### Differential circuit-breaker:

- Nominal current: 5A.
- Nominal voltage application: 230V / 240V, 50Hz.
- Breaking capacity: I<sub>cn</sub> = 3kA.
- Differential sensitivity: I<sub>Δ</sub> = 300mA.
- Breaking curve: type C.
- Differential breaking: instantaneously.

#### Power socket:

- Bipolar plug + earthing (type NF C 61-314).
- Female type.

#### Option :

As an alternative to the electronic load limiter, another interface is available with a 1A thermal limiter. (K832)

Please enquire.



Code	Designation	Weight (kg)	Sales unit
K811	CUSTOMER BOARD 50-75VA	1.000	1
K812	CUSTOMER BOARD 75-250VA	1.000	1
K813	CUSTOMER BOARD 250-1000VA	1.000	1



SEE SHEET

Modular cabinets : make up your own solution



## Meter cabinet RE for IGA's

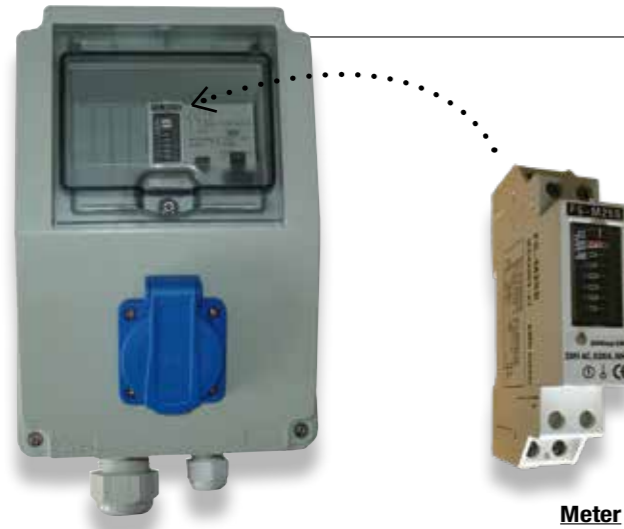

Meter

### Application

This 2 outputs meter cabinet is a solution perfectly suitable for Rural Electrification (RE) and particularly Income Generating Activities (IGA's).

It comprises an internal circuit breaker, a meter and a differential circuit breaker to ensure goods and people protection.

It is equipped with an input through a large cable gland for power supply and 2 outputs:

- An electrical outlet for simple access to energy,
- Second outlet through a smaller cable gland and black domino terminal for home wiring.

The whole set is pre-wired.

Ideally, it can be installed inside the home or below a shelter.

### Description

#### Envelop:

- Synthetic materials.
- Dimensions (L x W x D): 220(260)x150x120mm.
- Mounted / connected: cutout 10.3x38 (hidden) / meter / differential circuit-breaker / earthing terminal / power socket and terminal black domino terminal.
- Cable gland at the bottom used to route power cables (2x6-16mm<sup>2</sup> - diameter 13 up to 18mm).
- Movable window on the front side making the access to modular devices easier.
- First outlet with power socket having closed protection cover IP54.
- Second outlet with cable gland allowing leading-out cable (2x2.5mm<sup>2</sup> - diameter 5 up to 10mm).
- IP43 Device with conductors.
- Fitted with precuts at the bottom enabling the fixing of the envelope with screws, on every kind of material.
- Anti-fraud: sealing possibility preventing the access to the live areas.

#### Cut out:

- Disconnection: Phase and Neutral.
- Hidden cutout, inaccessible from the user.

#### Differential circuit-breaker:

- Nominal current: 1A, 3A, 5A, 10A or 15A.
- Nominal voltage application: 230V / 240V, 50Hz.
- Breaking capacity: I<sub>cn</sub> = 3kA.
- Differential sensitivity: I<sub>Δ</sub> = 300mA.
- Breaking curve: type C.
- Differential breaking: instantaneously.

#### Power socket:

- Bipolar plug + earthing (type NF C 61-314).
- Female type.



#### Meter:

- Single phase type meter of 1 module size (18mm width).
- Class of measure: 1.
- Voltage rate: 230VAc ±10%.
- Frequency: 50Hz.
- Maximal current: 30A.

Code	Designation	Weight (kg)	Sales unit
K851	METER CABINET 2.0 1A	1.000	1
K853	METER CABINET 2.0 3A	1.000	1
K855	METER CABINET 2.0 5A	1.000	1
K856	METER CABINET 2.0 10A	1.000	1
K857	METER CABINET 2.0 15A	1.000	1
K858	METER CABINET 2.0 32A	1.000	1

### Option:

As an alternative, the meter cabinet is proposed with one output (1.0), access to energy being possible only through the power socket on the front side.



Code	Designation	Weight (kg)	Sales unit
K841	METER CABINET 1.0 1A	1.000	1
K843	METER CABINET 1.0 3A	1.000	1
K845	METER CABINET 1.0 5A	1.000	1
K846	METER CABINET 1.0 10A	1.000	1
K847	METER CABINET 1.0 15A	1.000	1



SEE SHEET

Modular cabinets: make up your own solution



# Modular cabinets : make up your own solution

1. Choose your cabinet

## Individual cabinet

The transparent front door enables a clear readability of components like LED. Modules are fixed on DIN rail. It is implemented in a shelter or inside the premise.



## Benefits ?

- + Customized solution
- + Wide range of customers' management
- + Possibility to combine different management modules
- + Several protection technologies
- + Components implemented in serie and/or in parallel

## Collective cabinet

The cabinet enables to gather equipment to optimize costs of several connections. Modules are fixed on DIN rail. It is implemented at the top of a pole.

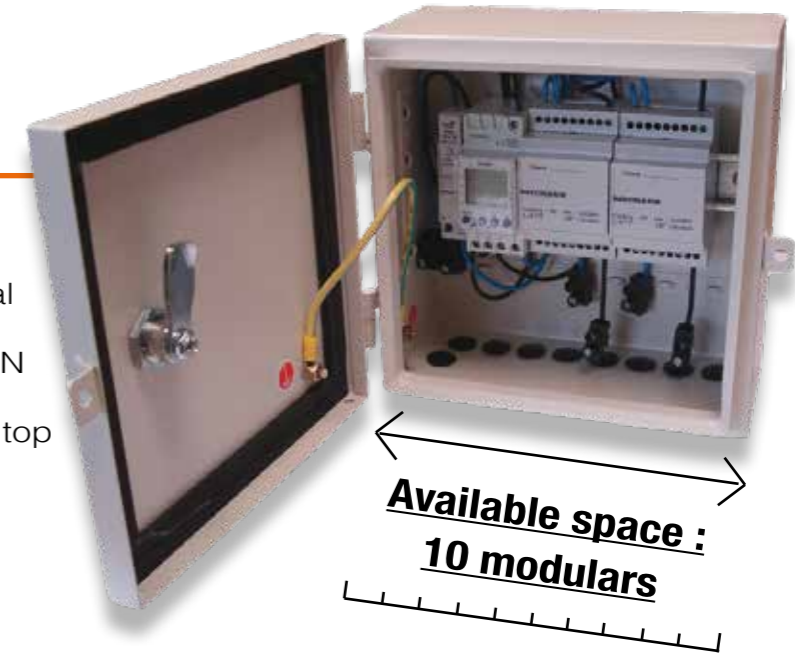

To support you in the choice of your system, consult us.

2. Select your functions

Management				Protection			
 Power Flat fee	 Power Flat fee	 Time Flat fee	 Time Flat fee OR Energy Flat fee				
 Load limiter	 Thermal limiter	 Clock	 Energy manager	 Mechanical and electronical meters	 Cut-out	 Circuit breaker	 Differential cut-out
3 MODULARS	1 MODULAR	2 MODULARS	3 MODULARS	1 MODULAR	1 MODULAR	1 MODULAR	2 MODULARS

Access to energy

Access to energy



## Reliable and optimized electricity distribution

# SOLUTIONS FOR THE ENERGY DISTRIBUTION

### Issues



As a part of rural electrification programs, **electricity distribution costs** represent a significant budget and are often undervalued. In most cases, those additional charges are due to the transposition of traditional electrification models, without taking care of the economic, social and cultural context of developing countries.



Michaud proposes simplified solutions for low voltage connections, following international standards, from the HV/LV transformer aval post to the end customer. The result is **15% to 30% saving** enabling to connect more households and villages with the allocated budget !

### Benefits

- + Costs reduction
- + Adaptation to local context
- + Optimized access to energy



## Aerial service cable

IEC 60502



**Michaud Exclusivity**  
6mm<sup>2</sup> optimized  
section

### Application

This single phase or three-phase aerial cable is used for the connection between the low voltage network and the home. It is perfectly suitable for electrification applications in rural and suburban areas thanks to its optimized 6mm<sup>2</sup> section. It is stretched to a maximum range of 40m.

### Description

- This single phase or three phase cable respectively consists of 2 or 4 twisted insulated conductors, phase(s) and neutral.
- Service voltage rate: 600V.
- Conductors core made of aluminium:
  - Conductors section: 6mm<sup>2</sup>
  - Diameter over core: 3.12mm
  - Number of strands: 7
  - Diameter of strands: 1.04mm
  - Mechanical strength of strands: 18.5daN/mm<sup>2</sup>
  - Minimum strain of strands: 1.2%
  - Step factor: 10 - 16
  - Step direction: right
- Conductors insulation made of polyethylene:
  - Nominal insulation thickness: 1.2mm
  - Minimum insulation thickness: 0.98mm
  - Diameter over insulation: 5.52mm
- Cable characteristics:
  - Phase identification: marking
  - Twist step factor: 25 - 60
  - Twist step direction: right
  - Twist weight: 75kg / km
  - Dielectric test / water: 2.5kVac / 1 min
  - Linear strength to 20°C: 4.5Ω/km
  - Maximum intensity in permanent capacity in the open air: 30A
  - Maximum temperature in service: 90°C
- This cable meets the acceptance criteria of the IEC 60502 standard.

Code	Designation	Packaging	Weight (kg)	Sales unit
U300	AERIAL SERVICE CABLE 2x6mm <sup>2</sup>	200m ring	15	1
U304	AERIAL SERVICE CABLE 4x6mm <sup>2</sup>	200m ring	30	1



Other cable sections available.

Please enquire.

## Accessories dedicated to the 6mm<sup>2</sup> cable

EN 50483 CE NF



This insulation piercing connector is used to perform a tap connection from a network from 16 up to 95mm<sup>2</sup> with the 6mm<sup>2</sup> aerial service cable.

L227



Cable ends are used to facilitate the insertion of cables into terminals like breaker. The retention of the cable is made thanks to crimping.

F62x

Code	Designation	Weight (kg)	Sales unit
L227	CONNECTOR CES/CT 95	0.060	200
F625	CABLE END FOR 6mm <sup>2</sup> (Batch of 100)	0.100	1
F627	CABLE END FOR 16mm <sup>2</sup> (Batch of 100)	0.120	1



L306

L304



U500

This accessory is used for supporting service network of type 2x6 up to 4x25mm<sup>2</sup>.

K265



This anchoring clamp is used to fix 2x6mm<sup>2</sup> service cable between the pole and the home. It can be associated with the fixing clamp (L304) for implementation on a wall or a pole, thanks to a screw M10 (L306) or strap.

Code	Designation	Weight (kg)	Sales unit
U500	ANCHORING CLAMP 2x6mm <sup>2</sup> - PA6	0.100	60
U500 4x6	ANCHORING CLAMP 4x6mm <sup>2</sup> - PA4x6	0.120	60
L304	FIXING CLAMP - PF25	0.010	100
L306	SCREW M10	0.048	50
K265	BELT SUSPENSION WITH RING	0.020	25



SEE SHEET  
ACCESS TO ENERGY / Distribution / Stainless steel strap



This tool is perfectly adapted to strip 6mm<sup>2</sup> section cables to facilitate wiring to equipment.

Code	Designation	Weight (kg)	Unit sale
F493	STRIPPING TOOL 6mm <sup>2</sup>	0.150	1

# Low voltage twisted insulated cable

## Network



U096

### Application

This cable is used for low voltage electrical distribution (0.6 / 1kV, 50Hz). The cable comprises a neutral messenger which is twisted with the rest of the conductors. One or several street light conductors are possible, consult us.

### Description

- This cable has a working temperature of -60 °C to + 50 °C.
- The minimum installation temperature is -20 °C.
- The maximum allowed conductor temperature is + 90 °C.
- The bend radius of curvature corresponds to 10 x diameter of the conductor.

Code	Designation	Diameter of the cable (mm)	Weight of the cable (kg/km)
<b>NEUTRAL MESSENGER</b>			
U096-3x16+54.6	INSULATED LOW VOLTAGE CABLE 3x16 + 54.6mm <sup>2</sup>	18	404
U096-3x25+54.6	INSULATED LOW VOLTAGE CABLE 3x25 + 54.6mm <sup>2</sup>	21	495
U096-3x35+54.6	INSULATED LOW VOLTAGE CABLE 3x35 + 54.6mm <sup>2</sup>	23	577
U096-3x50+54.6	INSULATED LOW VOLTAGE CABLE 3x50 + 54.6mm <sup>2</sup>	26	702
U096-3x70+54.6	INSULATED LOW VOLTAGE CABLE 3x70 + 54.6mm <sup>2</sup>	34	1015
U096-3x70+70	INSULATED LOW VOLTAGE CABLE 3x70 + 70mm <sup>2</sup>	36	1118
<b>NEUTRAL MESSENGER + STREET LIGHT CONDUCTOR</b>			
U096-3x25+54.6+16	INSULATED LOW VOLTAGE CABLE 3x25 + 54.6mm <sup>2</sup> + 16mm <sup>2</sup>	22	467
U096-3x35+54.6+16	INSULATED LOW VOLTAGE CABLE 3x35 + 54.6mm <sup>2</sup> + 16mm <sup>2</sup>	30	783
U096-3x50+54.6+16	INSULATED LOW VOLTAGE CABLE 3x50 + 54.6mm <sup>2</sup> + 16mm <sup>2</sup>	31	821
U096-3x70+54.6+16	INSULATED LOW VOLTAGE CABLE 3x70 + 54.6mm <sup>2</sup> + 16mm <sup>2</sup>	38	581

Others dimensions are available, [consult us](#).

## Service



U313

### Application

This cable is used for the low voltage electricity overhead distribution. The conductor core is aluminum of wired type, covered with XLPE insulation.

### Description

- The cable is delivered on wooden drums.
- The cable is available in single-phase 2x16mm<sup>2</sup> and 2 x 25mm<sup>2</sup> or three-phase 4x16mm<sup>2</sup> and 4x25mm<sup>2</sup> bundles.
- Each conductor is composed of 7 strands.

This cable meets the criteria of the **NF C 33-209** standard.

Nominal section (mm <sup>2</sup> )	Nominal insulation thickness (mm)	External diameter of the maximal conductor (mm)	Approximate weight (kg/km)	Maximum resistance at 20 °C (Ω/km)
2 x 16	1.20	5.1	130	1.91
4 x 16	1.20	5.1	280	1.91
2 x 25	1.40	9.4	205	1.20
4 x 25	1.40	9.4	512	1.20

Code	Designation	Sales unit
U305	METER OF TWISTED CABLE 2x16mm <sup>2</sup>	The minimum sales unit is 1000m and then in 100m steps.
U306	METER OF TWISTED CABLE 4x16mm <sup>2</sup>	
U312	METER OF TWISTED CABLE 2x25mm <sup>2</sup>	
U313	METER OF TWISTED CABLE 4x25mm <sup>2</sup>	

## Overhead connectors

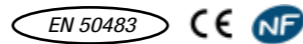

### Network

#### Application

These connectors are used to make a tap connection between aerial networks. The connection is realised by means of insulation piercing technology. Three models are available :



**L256-EC**

Network connector used to make a tap connection between aerial networks (capacities: 16-95 / 16-95mm<sup>2</sup>)



**U529**

Network connector used to make a tap connection between aerial networks (capacities : 25-150 / 25-150mm<sup>2</sup>)



**L356**

Network connector used to make a tap connection between aerial networks (capacities: 35-150 / 35-150mm<sup>2</sup>)

Code	Designation	Capacities main (mm <sup>2</sup> )	Capacities tap (mm <sup>2</sup> )	Weight (kg)	Sales unit
L256-EC	CONNECTOR CDRS / CT 95 EC	16-95	16-95	0.140	50
U529	CONNECTOR CDRS / CT 150 (25-150/25-150) EC	25-150	25-150	0.195	50
L356	CONNECTOR CDRS / CT 150	35-150	35-150	0.400	30

### Service

#### Application

These connectors are used to make a tap connection from the network to the customer. Four models are available :



**L227**

Street light connector for powering street light lamp and performing tap connections of small section cables from a network. The connection is realised by means of insulation piercing technology. (capacities: 16-95 / 1.5-10mm<sup>2</sup>)

**K232**



Service connector used to perform a tap connection from the insulated network to the customer. The connection is realised by means of insulation piercing technology. (capacities: 16 (6) -95 / 2.5 (6) -35mm<sup>2</sup>). In general, the capacities of the connector are 16-95/2.5-35 mm<sup>2</sup>. In some specific applications, these capacities can be 6-95/6-35.



**L259**

Service connector used to perform a tap connection from a aluminium or copper bare conductor to an insulated one to connect the customer. (capacities: 6-35 / 7-95mm<sup>2</sup>)

**U533**



Service connector used to perform a tap connection from the insulated network to the customer. The connection is realised by means of insulation piercing technology. (capacities : 35-150 / 6-35mm<sup>2</sup>)

Code	Designation	Capacities main (mm <sup>2</sup> )	Capacities tap (mm <sup>2</sup> )	Weight (kg)	Sales unit
<b>Insulated conductors</b>					
L227	CONNECTOR CES / CT 95	16-95	1.5-10	0.060	200
K232	CONNECTOR CBS / CT 95	16 (6) -95	2.5 (6) -35	0.130	20
U533	CONNECTOR CBS / CT 35-150 / 6-35 A	35-150	6-35	0.100	100
<b>Bare conductors</b>					
L259	CONNECTOR RDP / CN abc 6-35 / AI 7-95	7-95	6-35	0.130	20



**SEE SHEET**  
Aerial service cable / Accessories / Stainless steel strap



Installation video available on the website [www.michaud-export.com](http://www.michaud-export.com)

## Mechanical fixing

### Anchoring



#### Utilisation

The anchoring assembly is used for single or double dead-ending of A.B.C (aerial bundled conductors) with insulated neutral messenger. Two different sections of neutral messenger are available: 54.6mm<sup>2</sup> and 70mm<sup>2</sup>.

Code	Designation	Weight (kg)	Sales unit
U501	ANCHORING CLAMP 54.6mm <sup>2</sup> - PA 54.6	0.410	30
U501-70	ANCHORING CLAMP 70mm <sup>2</sup> - PA 70	0.530	25
U502	ANCHORING BRACKET 54.6mm <sup>2</sup> - CA 54.6	0.235	50
U502-70	ANCHORING BRACKET 70mm <sup>2</sup> - CA 70	0.300	60

### Suspension



#### Utilisation

The suspension assembly is used to suspend a twisted isolated network. It is available in two versions: for a 54.6 mm<sup>2</sup> section neutral or for a 70mm<sup>2</sup> section neutral. The bracket is available for 54.6 mm<sup>2</sup> carrier neutral suspension clamps.

Code	Designation	Weight (kg)	Sales unit
U503	SUSPENSION ASSEMBLY 54.6mm <sup>2</sup> - ES 54.6	0.510	20
U503-70	SUSPENSION ASSEMBLY 70mm <sup>2</sup> - ES 70	0.650	20
U504	SUSPENSION ASSEMBLY 54,6 mm <sup>2</sup> - CS 54,6	0,490	30

### Service anchoring

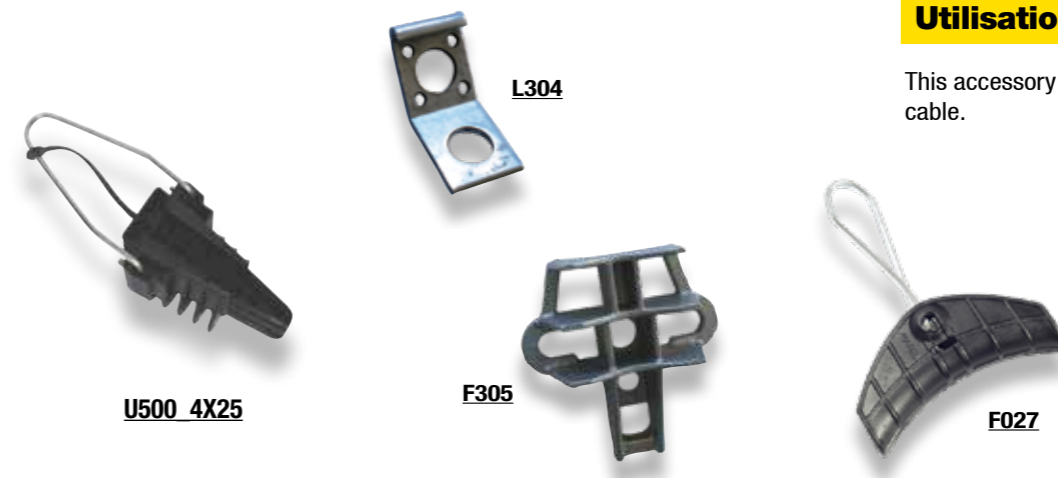

#### Utilisation

This accessory is used for anchoring service cable.

Code	Designation	Weight (kg)	Sales unit
U500_4X25	SERVICE ANCHORING CLAMP - PA 25	0.105	100
F027	ANGULAR CLAMP RA25	0.080	100
L304	FIXING CLAMP - PF25	0.010	100
F305	MULTIPLE ANCHORING BRACKET - CAM 25	0.220	100

Nota : For pole hardware (BQC) supplu, **please enquire**.

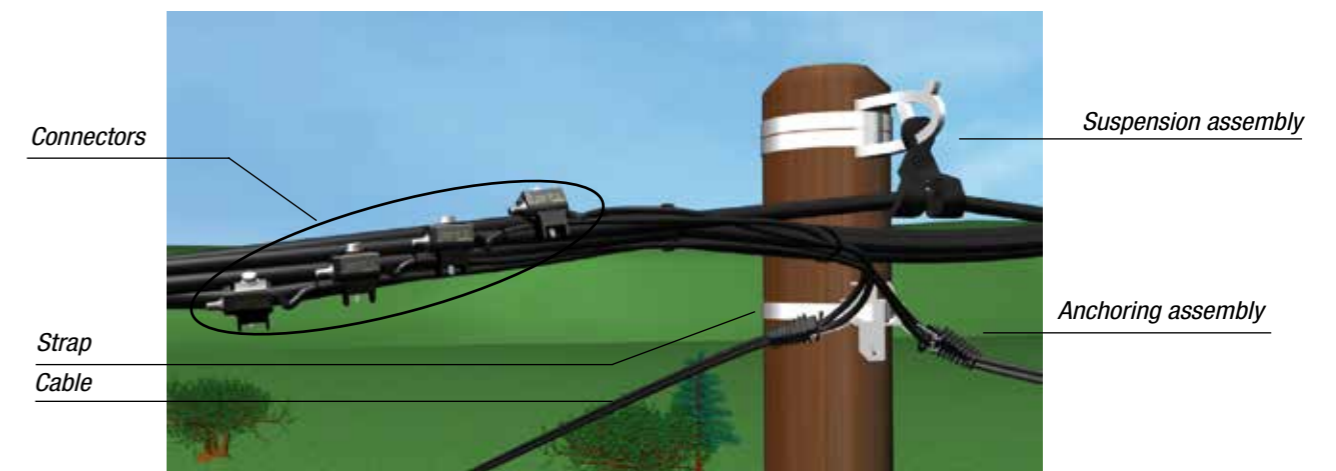

SEE SHEET  
Aerial service cable / Accessories / Stainless steel strap

## Aerial accessories

### Network junction



U507

#### Application

This preinsulated sleeve is designed for the junction of low voltage overhead insulated conductors to other ones. The junction can be established between two conductors of equal or unequal sections. All combinations of sections are possible.

#### Description

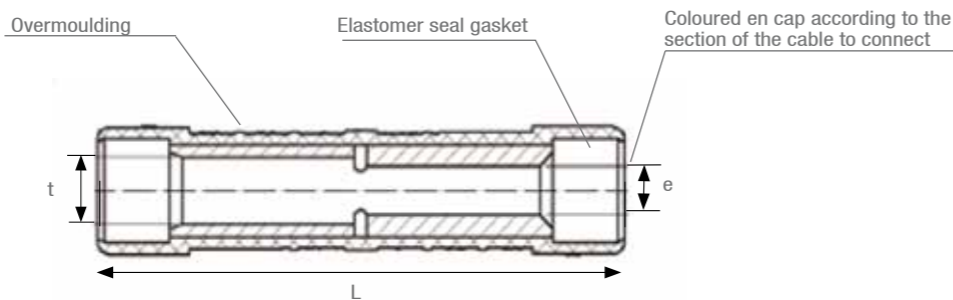

This preinsulated sleeve meets the requirements of the **NF C 33-021** and **EN 50-483** standards.

Code	Designation	Leading-in cable (mm <sup>2</sup> )	Leading-in colour	Leading-out cable (mm <sup>2</sup> )	Leading-out colour	Dimensions (mm)			Weight (kg)	Sales unit
						t	e	L		
<b>PHASE SLEEVE REQUIRING A E173 CRIMPING DIE</b>										
U507_16-16	MJPT SLEEVE 16-16	16	Blue	16	Blue	5.3	5.3		0.060	10
U507_25-25	MJPT SLEEVE 25-25	25	Orange	25	Orange	6.5	6.5		0.060	10
U507_35-25	MJPT SLEEVE 35-25	35	Red	25	Orange	7.9	6.5		0.050	10
U507_35-35	MJPT SLEEVE 35-35	35	Red	35	Red	7.9	7.9		0.060	10
U507_50-25	MJPT SLEEVE 50-25	50	Yellow	25	Orange	8.8	6.5		0.060	10
U507_50-35	MJPT SLEEVE 50-35	50	Yellow	35	Red	8.8	7.9		0.060	10
U507_50-50	MJPT SLEEVE 50-50	50	Yellow	50	Yellow	8.8	8.8		0.055	10
U507_70-25	MJPT SLEEVE 70-25	70	White	25	Orange	10.4	6.5	98.5	0.050	10
U507_70-35	MJPT SLEEVE 70-35	70	White	35	Red	10.4	7.9		0.050	10
U507_70-50	MJPT SLEEVE 70-50	70	White	50	Yellow	10.4	8.8		0.050	10
U507_70-70	MJPT SLEEVE 70-70	70	White	70	White	10.4	10.4		0.050	10
U507_95-35	MJPT SLEEVE 95-35	95	Grey	35	Red	12.2	7.9		0.050	10
U507_95-50	MJPT SLEEVE 95-50	95	Grey	50	Yellow	12.2	8.8		0.050	10
U507_95-70	MJPT SLEEVE 95-70	95	Grey	70	White	12.2	10.4		0.050	10
U507_95-95	MJPT SLEEVE 95-95	95	Grey	95	Grey	12.2	12.2		0.050	10
<b>NEUTRAL SLEEVE REQUIRING A E173 CRIMPING DIE</b>										
U507_54N-54N	MJPTN SLEEVE 54-54	54.6	Black	54.6	Black	10.2	10.2		0.090	10
U507_54N-70N	MJPTN SLEEVE 54-70	54.6	Black	70	White	10.2	10.6	173.5	0.090	10
U507_70N-70N	MJPTN SLEEVE 70-70	70	White	70	White	10.2	10.6		0.080	10
<b>NEUTRAL SLEEVE REQUIRING A E215 CRIMPING DIE</b>										
U507_95N-95N	MJPTN SLEEVE 95-95	95	Grey	95	Grey	10.2	13.4	175.5	0.150	10

### Service junction



U509

#### Description

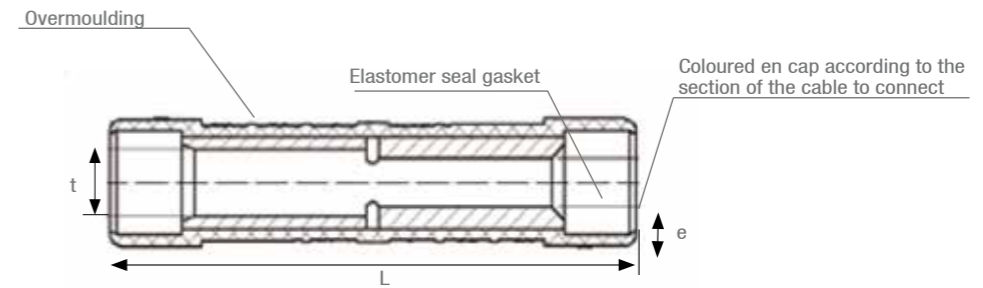

This preinsulated lug meets the requirements of the **NF C 33-021** and **EN 50-483** standards.

Code	Designation	Leading-in cable (mm <sup>2</sup> )	Leading-in colour	Leading-out cable (mm <sup>2</sup> )	Leading-out colour	Dimensions (mm)			Weight (kg)	Sales unit
						t	e	L		
<b>SERVICE SLEEVE E140</b>										
U509_4-4	MJPB SLEEVE 4-4	4	Ivory	4	Ivory	2.9	2.9		0.050	150
U509_4-6	MJPB SLEEVE 4-6	4	Ivory	6	Brown	3.3	2.9		0.050	150
U509_4-10	MJPB SLEEVE 4-10	4	Ivory	10	Green	4.3	2.9		0.050	150
U509_4-16	MJPB SLEEVE 4-16	4	Ivory	16	Blue	5.3	2.9		0.050	150
U509_4-25	MJPB SLEEVE 4-25	4	Ivory	25	Orange	6.5	2.9		0.050	150
U509_6-6	MJPB SLEEVE 6-6	6	Brown	6	Brown	3.3	3.3		0.050	150
U509_6-10	MJPB SLEEVE 6-10	6	Brown	10	Green	4.3	3.3		0.050	150
U509_6-16	MJPB SLEEVE 6-16	6	Brown	16	Blue	5.3	3.3		0.050	150
U509_6-25	MJPB SLEEVE 6-25	6	Brown	25	Orange	6.5	3.3		0.050	150
U509_6-35	MJPB SLEEVE 6-35	6	Brown	35	Red	7.9	3.3		0.050	150
U509_10-10	MJPB SLEEVE 10-10	10	Green	10	Green	4.3	4.3		0.050	150
U509_10-16	MJPB SLEEVE 10-16	10	Green	16	Blue	5.3	4.3	74	0.050	150
U509_10-25	MJPB SLEEVE 10-25	10	Green	25	Orange	6.5	4.3		0.050	150
U509_10-35	MJPB SLEEVE 10-35	10	Green	35	Red	7.9	4.3		0.050	150
U509_16-16	MJPB SLEEVE 16-16	16	Blue	16	Blue	5.3	5.3		0.050	150
U509_16-25	MJPB SLEEVE 16-25	16	Blue	25	Orange	6.5	5.3		0.050	150
U509_16-35	MJPB SLEEVE 16-35	16	Blue	35	Red	7.9	5.3		0.050	150
U509_16-50	MJPB SLEEVE 16-50	16	Blue	50	Yellow	8.8	5.3		0.050	150
U509_25-25	MJPB SLEEVE 25-25	25	Orange	25	Orange	6.5	6.5		0.050	150
U509_25-35	MJPB SLEEVE 25-35	25	Orange	35	Red	7.9	6.5		0.050	150
U509_25-50	MJPB SLEEVE 25-50	25	Orange	50	Yellow	8.8	6.5		0.050	150
U509_35-35	MJPB SLEEVE 35-35	35	Red	35	Red	7.9	7.9		0.050	150
U509_35-50	MJPB SLEEVE 35-50	35	Red	50	Yellow	8.8	7.9		0.050	150

SEE SHEET  
ACCESS TO ENERGY / Distribution / Aerial accessories / Tooling



## Aerial accessories

### Ending fitting



U506

#### Application

This spin-welded preinsulated lug is designed to connect low voltage overhead insulated conductors to copper equipment terminals. The cable sections range that the lug can receive goes from 16 to 150mm<sup>2</sup>.

#### Description

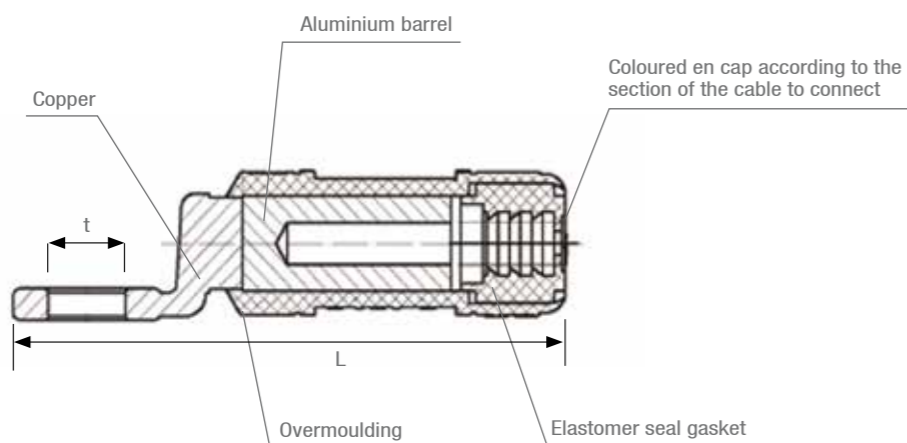

This preinsulated lug meets the requirements of the **NF C 33-021** and **EN 50-483** standards.

Code	Designation	Insulated Al-Cu cable (mm <sup>2</sup> )	Dimensions (mm)		Weight (kg)	Sales unit
			t	L		
<b>SPIN-WELDED PREINSULATED LUG REQUIRING A E140 CRIMPING DIE</b>						
U506_16-10	CPTAU SPIN-WELDED LUG 16mm <sup>2</sup> - DIAM 10	16	10.3	75	0.040	10
<b>SPIN-WELDED PREINSULATED LUG REQUIRING A E173 CRIMPING DIE</b>						
U506_25-10	CPTAU SPIN-WELDED LUG 25mm <sup>2</sup> - DIAM 10	25	10.3	100	0.040	10
U506_35-13	CPTAU SPIN-WELDED LUG 35mm <sup>2</sup> - DIAM 13	35	13	100	0.070	10
U506_50-13	CPTAU SPIN-WELDED LUG 50mm <sup>2</sup> - DIAM 13	50	13	100	0.070	10
U506_54-13	CPTAU SPIN-WELDED LUG 54.6mm <sup>2</sup> - DIAM 13	54.6	13	100	0.070	10
U506_70-13	CPTAU SPIN-WELDED LUG 70mm <sup>2</sup> - DIAM 13	70	13	100	0.070	10
U506_95-13	CPTAU SPIN-WELDED LUG 95mm <sup>2</sup> - DIAM 13	95	13	100	0.070	10
<b>SPIN-WELDED PREINSULATED LUG REQUIRING A E215 CRIMPING DIE</b>						
U506_120-13	CPTAU SPIN-WELDED LUG 120mm <sup>2</sup> - DIAM 13	120	13	118	0.220	10
U506_150-13	CPTAU SPIN-WELDED LUG 150mm <sup>2</sup> - DIAM 13	150	13	118	0.220	10

### Tooling



F460



F445



K007



K005



U813-2



F400



F420 - F421 - F422

#### Application

These tools are used for the installation of pre-insulated connectors, sleeves and lugs.

Code	Designation	Weight (kg)	Sales unit
<b>TOOLING FOR CONNECTORS INSTALLATION</b>			
F445	INSULATED RATCHET WRENCH HEXAGONAL 13/17mm	0.380	1
F460	INSULATED CROSS SPANNER 8-10-13-17mm	0.400	1
K005	INSULATED WEDGE SEPARATOR	0.360	5
K007	INSULATED WEDGE SEPARATOR 200x15x9mm	0.050	100
<b>TOOLING FOR SPIN-WELDED AND SLEEVE</b>			
F400	50kN HYDRAULIC CRIMPING TOOL	2.350	1
F420	HEXAGONAL DIE TYPE E140	0.115	1
F421	HEXAGONAL DIE TYPE E173	0.115	1
F422	HEXAGONAL DIE TYPE E215	0.115	1
<b>MEASURING DEVICE</b>			
U813-2	CLAMP AMMETER	0.520	1

## Stainless steel strap



### Application

This stainless steel strap is mainly used to fix the suspension or anchoring clamp brackets on all types of poles (wooden, metal or concrete).

### Description

- This strap packaged in a 50m or 25m winder is available in four dimensions:
  - 10 x 0.4mm - 3/8"
  - 10 x 0.7mm - 3/8"
  - 20 x 0.4mm - 3/4"
  - 20 x 0.7mm - 3/4"
- The strap is made of stainless steel. The strap edges are deburred.
- The strap delivered in a roll inside a strengthened cardboard winder.

Code	Designation	Winder length (m)	AISI	Weight (kg)	Sales unit
<b>Dimensions 10x0.4 - 3/8"</b>					
K920	50m CARDBOARD WINDER STAINLESS STEEL STRAP 10x0.4mm - 3/8" - AISI 201	50	201	1.740	5
K920-304	50m CARDBOARD WINDER STAINLESS STEEL STRAP 10x0.4mm - 3/8" - AISI 304	50	304	1.740	5
K940	50m CARDBOARD WINDER STAINLESS STEEL STRAP EC 10x0.4mm - 3/8" - AISI 430	50	430	1.740	5
<b>Dimensions 10x0.7 - 3/8"</b>					
K919	25m CARDBOARD WINDER STAINLESS STEEL STRAP 10x0.7mm - 3/8" - AISI 201	25	201	1.500	5
K921	50m CARDBOARD WINDER STAINLESS STEEL STRAP 10x0.7mm - 3/8" - AISI 201	50	201	2.840	5
K924	25m CARDBOARD WINDER STAINLESS STEEL STRAP EC 10x0.7mm - 3/8" - AISI 430	25	430	1.500	5
K941	50m CARDBOARD WINDER STAINLESS STEEL STRAP EC 10x0.7mm - 3/8" - AISI 430	50	430	2.840	5
<b>Dimensions 20x0.4 - 3/4"</b>					
K922	50m CARDBOARD WINDER STAINLESS STEEL STRAP 20x0.4mm - 3/4" - AISI 201	50	201	3.340	5
K942	50m CARDBOARD WINDER STAINLESS STEEL STRAP EC 20x0.4mm - 3/4" - AISI 430	50	430	3.340	5
<b>Dimensions 20x0.7 - 3/4"</b>					
K918	25m CARDBOARD WINDER STAINLESS STEEL STRAP 20x0.7mm - 3/4" - AISI 201	25	201	2.980	5
K923	50m CARDBOARD WINDER STAINLESS STEEL STRAP 20x0.7mm - 3/4" - AISI 201	50	201	5.690	5
K936	25m CARDBOARD WINDER STAINLESS STEEL STRAP EC 20x0.7mm - 3/4" - AISI 430	25	430	2.980	5
K943	50m CARDBOARD WINDER STAINLESS STEEL STRAP EC 20x0.7mm - 3/4" - AISI 430	50	430	5.690	5

### Tools



### Description

The carrying case with ergonomic inside trim is made of synthetic material. It includes a cutting tool, binding tool ratchet type and buckles (to be ordered separately).

### Implementation

- Cut the required length of strap using the cutting tool.
- Fix the strap around the pole and bracket using a binding tool and attach a buckle.
- Keep the cutting tool and binding tool in the suitable carrying case.

Code	Designation	Weight (kg)	Sales unit
L950	YOKES EC FOR 10mm STRAP (x100)	0.320	1
L951	YOKES EC FOR 20mm STRAP (x100)	0.610	1
K960	BINDING TOOL RATCHET TYPE FOR STRAP	1.950	1
K961	CUTTING TOOL FOR STRAP	0.550	1
K963	CARRYING CASE FOR STRAP TOOLS	0.550	1

### Anti-climbing buckles



### Application

These stainless steel buckles are fixed onto the strap to prevent climbing on the pole and the fraud attempt.

Code	Designation	Weight (kg)	Sales unit
K956	SET OF 25 ANTI-CLIMBING STAINLESS STEEL BUCKLES	0.580	1



Video implementation available on the website [www.michaud-export.com](http://www.michaud-export.com)



## Source, network and safety protection

# SOLUTIONS FOR THE NETWORK PROTECTION

### Issues ?



Harsh climates of many developing countries create regularly disruptions on the lines. In order to protect people, the electrical production sources and networks, Michaud offers some **economical and enduring alternatives** to traditionnal solutions.



Mostly used in Europe, the thermal image circuit-breaker, installed at the top of the pole, causes inopportune power cuts in case of phases imbalance on the network. To avoid this inconvenience, Michaud has designed a very **economical fuse switch disconnecter equipped with fuses of high breaking capacity (HBC)**. This system has the advantage to add protection and breaking points, making easier the network operating and maintenance.



Michaud also proposes **earth system solutions** for people and installations protection.

### Benefits ?

- + Safe and sustainable installations
- + Medium and long term profitability
- + Easier networks operating and maintenance



## Reduced urban panel



F751



F752

### Application

These reduced urban panels TUR are used to protect low voltage distribution networks. They can be installed into the distribution station.

### Description

- The reduced urban panel TUR is made of a three-poles switch with abrupt interlock and trigger, an aluminium set of bars (Phase 1 -2 - 3 and neutral).
- The whole set is installed on a metal chassis.
- The inlets can receive cables with mechanical tightening terminal lug (up to 630mm<sup>2</sup>).
- The outlet is ensured by a 400A monobloc feeder including: 3 circuit breakers, 1 cutout blade for neutral, 3 bars of feeder (Phases 1-2-3) and 1 bar of neutral outlet.
- The switch circuit breaker has a breaking capacity of 400A under load with a tension of 250V and a Cos φ of 0.9.
- It is made to receive size 2 fuses, 115mm. The monobloc feeder allows the connection of a unipolar cable with maximal cross-section 240mm<sup>2</sup> (aluminium or copper).
- A street light connection for the station is located before the switch (breakout bipolar fuse 10.3x38 10A with a neutral tube).
- This low voltage panel is equipped of 4 mounting brackets.

#### T4 - 800A :

- This panel can be equipped with 4 monobloc feeders which can be implemented with size 2 fuses, 115mm.
- It is equipped with a general cutting device.

#### Characteristics:

- Intensity : 800A.
- Nominal tension : 440V.
- Test tension : 50 Hz, 1 minute, 10 kV compared to earth.
- Shock wave tension : 20 kV.
- Breaking capacity of the switch with a nominal intensity on 440V cos φ = 0,9.
- Closing capacity of the switch : 16 000A effective and 32 000A peak with cos φ = 0.35.

### Description

#### T8 - 1 200A / 1 800A :

- This panel can be equipped with 8 monobloc feeders which can be implemented with size 2 fuses, 115mm.
- It is equipped with a general cutting device.

#### Characteristics:

- Intensity : 1200A / 1800A.
- Nominal tension : 440V.
- Test tension : 50 Hz, 1 minute, 10 kV compared to earth.
- Shock wave tension : 20 kV.
- Breaking capacity of the switch with a nominal intensity on 440V cos φ = 0,9.
- Closing capacity of the switch :
  - 25 000A effective et 52 000A peak with cos φ = 0.25 for T8 - 1 200A.
  - 32 000A effective et 72 000A peak with cos φ = 0.20 for T8 - 1 800A.

These reduced urban panels meet the criteria of the **HN 63-S-61** standard.

#### Insulated operation wrench:

- Hexagonal made of forged steel.
- Insulated for 10kV.

#### Closing panel for short-circuiting and test:

- This panel, made of insulated material blocks out one outlet, the three fuses being removed.
- It is lockable by means of 3 horizontal screws for each outlet.

Code	Designation	Sales unit
F750	REDUCED URBAN PANEL TUR T4 - 800	1
F749	REDUCED URBAN PANEL TUR T8 - 1200	1
F751	REDUCED URBAN PANEL TUR T8 - 1800	1
F752	MONOBLOC FEEDER	1
F753	CIRCUIT-BREAKER PROTECTOR	1
F754	INSULATED OPERATION WRENCH	1
F755	CLOSING PANEL FOR TUR T4 - 800	1

Note: Fuses are sold separately. Please consult us.

### Option : Lock key

This lock type artillery is designed to close transformation station. Each lock has the same key for easier operation.

Code	Designation	Sales unit
F770	TRIANGULAR ARTILLERY LOCK KEY	1
F771	WRENCH	1

Note: Please consult us for the reservation panel.

## LV network fuse protection Gang fuse switch disconnecter



### Application

This multi-pole fuse switch disconnecter device is installed below a transformer at the top of the pole. It provides protection up to 160A or cut-off up to 240A. It is attached to the pole and thus protects the transformer and the low-voltage network below it. It protects single phase and three phase transformers.

### Description

- The switch disconnecter is installed downstream:
  - Of the transformer 50kVA with fuses 80A,
  - Of the transformer 100kVA with fuses 160A,
  - Of the transformer 160kVA with neutral blade contacts, in order to create a breaking point on the network, each network outlet being possibly and independently protected with a disconnecter.
- This protection system is designed to secure the opening with cable energised and loaded.
- The terminals authorise a connection up to 95mm<sup>2</sup>. The connection is performed with insulation piercing technology, insuring a reliable and secured contact.

### The benefits :

- + 50 to 80% more economical than a circuit breaker
- + Strong solution, very little sensitive to charge imbalances
- + Solution available in single phase and in three phases

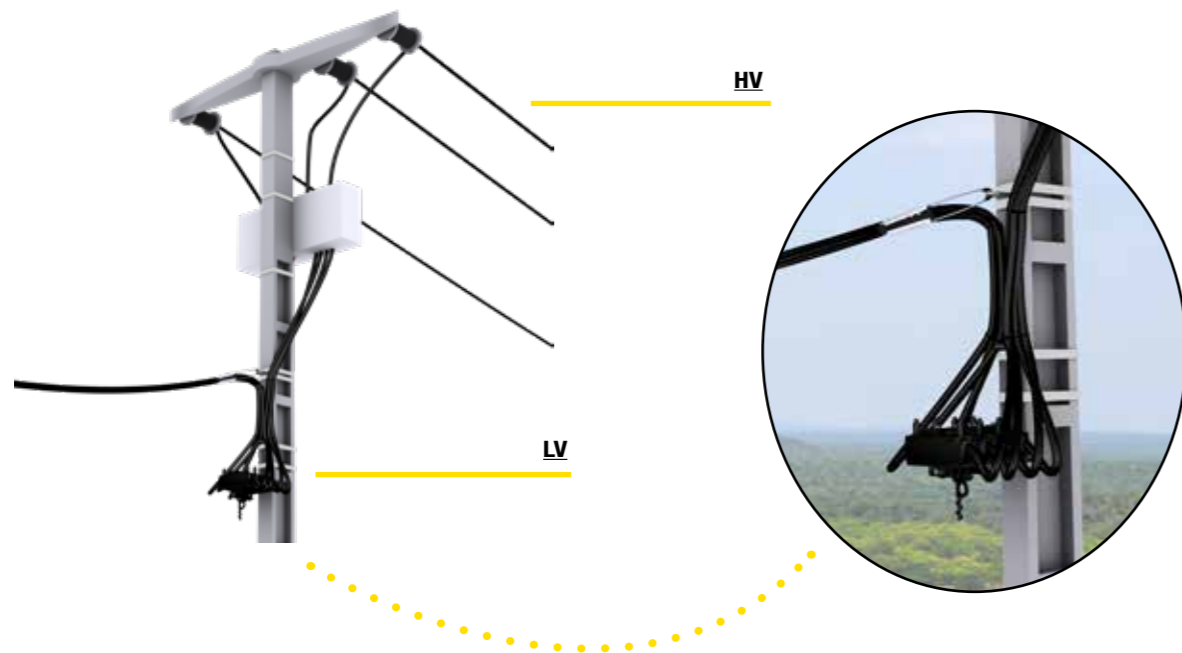

### Option : Double Departure

A double start can be achieved thanks to the two insulating perforation derivatives with a capacity of 6-35mm<sup>2</sup>.

Code	Designation	Weight (kg)	Sales unit
K298	DOUBLE POLE FUSE SWITCH DISCONNECTOR 160A (Size 00)	1.850	1
K293	TRIPLE POLE FUSE SWITCH DISCONNECTOR 160A (Size 00)	2.710	1
K294	QUADRUPLE POLE FUSE SWITCH DISCONNECTOR 160A (Size 00)	3.240	1
K098	DOUBLE TAP END CONNECTOR (6-35 mm <sup>2</sup> )	1.850	1
K098	DOUBLE TAP END CONNECTOR (6-35mm <sup>2</sup> )	0.115	12

Fixing with 2 galvanized steel screws of 10mm diameter is supplied with the disconnecter console.

SEE SHEET  
ACCESS TO ENERGY / Protection / Fuses

### Operating stick



### Utilisation

This stick when equipped with an end enables to manipulate the fuse carrier from the ground. Its length is 2.65 folded and 5m unfolded. Each model is equipped with a notched universal U-shaped terminal end.

Code	Designation	Weight (kg)	Sales unit
F203	STICK 2E - 5M (TERMINAL U)	3.000	1
F209	BORED TERMINAL END DISCONNECTOR / STICK	0.105	10



Installation video available on the website [www.michaud-export.fr](http://www.michaud-export.fr)



## Fuses

### Fuse cartridge gG

- Available in:
- 10.3x38
  - 14x51
  - 22x58



U66x

#### Application

These gG fuses cartridges are designed to protect goods. They are implemented in a cutout sheltered from outside weather conditions.

#### Description

- It is type gG HPC (High Breaking Capacity).
- It is not equipped with light indicator .

This fuse meets the criteria of the **NF/EN/IEC 60269-1**, **NF HD/IEC 60269-2**, **NF C 60200-1** et **NF C 60200-2** standards.

Code	Designation	Available models	Weight (kg)	Sales unit
U66X	FUSE CARTRIDGE 10.3x38 gG	1A to 32A	0.007	10
U66X	FUSE CARTRIDGE 14x51 gG	1A to 50A	0.021	10
U64X	FUSE CARTRIDGE 22x58 gG	2A to 32A	0.021	10

### Fuse AD

- Available in :
- 10.3x38
  - 14x51
  - 22x58



U61x

#### Utilisation

These AD fuse cartridges are used together with the circuit-breaker installed on the individual service tap connection. They perform the cutoff for high short-circuit currents and thereby extend the service life of the associated circuit-breaker, which is not overloaded up to the limit.

#### Description

- Low power loss limits heating of the device holding the fuse and extends its service life.
- It is specified for a nominal voltage of 440V in alternating current with nominal frequency of 50Hz.
- The nominal breaking capacity is 20kA.

This fuse meets the criteria of the **HN 62-S-83**, **NF/EN/IEC 60269-1**, **NF HD/IEC 60269-2** et **NF C60200-2** standards.

Code	Designation	Available models	Weight (kg)	Sales unit
<b>Size 10.3x38</b>				
U61X	FUSE CARTRIDGE 10.3x38 AD	5A - 10A	0.009	10
U620	NEUTRAL TUBE 10.3x38		0.012	10
<b>Size 14x51</b>				
U61X	FUSE CARTRIDGE 14x51 AD	15A - 30A - 45A	0.021	10
U621	NEUTRAL TUBE 14x51		0.016	10
<b>Size 22x58</b>				
U61X	FUSE CARTRIDGE 22x58 AD	15A - 30A - 45A - 60A - 90A	0.056	10
U622	NEUTRAL TUBE 22x58		0.028	10

### Fuse cartridge size 00 AD



P24x

#### Utilisation

These AD fuse cartridges are used together with the circuit-breaker installed on the individual service tap connection. They perform the cutoff for high short-circuit currents and thereby extend the service life of the associated circuit-breaker, which is not overloaded up to the limit.

#### Description

- The size of this blade fuse cartridge is 00 according to the **IEC 60269-2-1** standard.
- The fixing brackets are made of insulating synthetic materials.
- The accessible metal parts (screws), with the exception of the blades, are potential free and also have the degree of protection IP2X according to the **NF EN 60529** standard.
- Low power loss limits heating of the device holding the fuse and extends its service life.
- It is specified for a nominal voltage of 440V in alternating current with nominal frequency of 50Hz.
- The nominal breaking capacity is 20kA.

This fuse meets the criteria of the **HN62-S-83** standard.

Code	Designation	Available models	Weight (kg)	Sales unit
P24X	FUSE CARTRIDGE SIZE 00 AD	30A to 90A	0.150	10
P240	NEUTRAL BLADE CONTACT SIZE 00		0.060	10

### Fuse cartridge NH

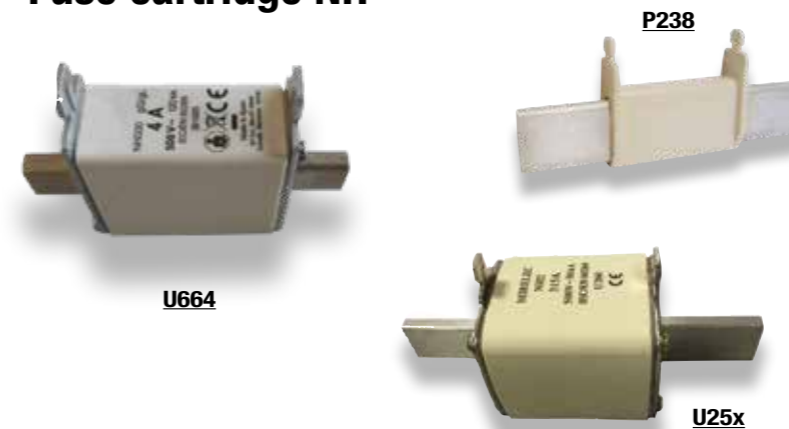

U664

P238

U25x

#### Application

These low voltage fuses cartridges NH00, NH1 or NH2 are type gG. They are used as protection unit of the low voltage public electricity supply networks and works. It is installed in:

- Low voltage switchboards of the public electricity supply substations,
- Cutout boxes, inside or outside supply switches,
- Switch cabinets for subsurface networks,
- Metering boxes and cabinets for different uses.

#### Description

- The size of this blade fuse cartridge is NH00, NH1 or NH2 according to the **IEC 269-2-1** standard.
- It is type gG HPC (High Breaking Capacity).
- It is specified for a nominal voltage of 440V in alternating current with nominal frequency of 50Hz.
- The nominal breaking capacity is 50kA minimum.

Code	Designation	Available models	Weight (kg)	Sales unit
U664	FUSE CARTRIDGE NH00 gG 500V	2A to 160A	0.180	3
U665	NEUTRAL BLADE CONTACT NH2 115mm		0.100	1
U25X	FUSE CARTRIDGE NH1 115mm	63A to 250A	0.400	5
U25X	FUSE CARTRIDGE NH2 115mm	125A to 400A	0.650	3
P238	NEUTRAL BLADE CONTACT NH2 115mm		0.210	1
P13X	FUSE CARTRIDGE NH2 160MM	125A to 400A	0.780	3
P239	NEUTRAL BLADE CONTACT NH2 160mm		0.290	1

## Earth system



U2XX ou F2XX

### Copper plated steel rod

#### Application

These earth rods are used for earth system power networks. The copper coating made by an electrolytic process gives a resistance to corrosion as well as a good conductivity. The reference Standard is **EN 50 164-2**.

Code	Designation	Nominal diameter (mm)	Real diameter (mm)	Length (m)	Weight (kg)	Sales unit
<b>50µm COPPER COATING</b>						
U203	EARTH ROD COPPER 50µm L = 1m DIAM 12.7	14	12.7	1	1.025	10
U204	EARTH ROD COPPER 50µm L = 1.5m DIAM 12.7	14	12.7	1.5	1.537	10
U205	EARTH ROD COPPER 50µm L = 2m DIAM 12.7	14	12.7	2	2.050	10
F226	EARTH ROD COPPER 50µm L = 1m DIAM 14	16	14	1	1.250	10
F244	EARTH ROD COPPER 50µm L = 1.5m DIAM 14	16	14	1.5	1.900	10
F245	EARTH ROD COPPER 50µm L = 2m DIAM 14	16	14	2	2.500	10



Other earth rod dimensions are available (from 1m to 3m) as well as other treatments and thicknesses

Please enquire.

#### Option:



Earth rod ends threading available for a potential extension with screwed sleeves.

Please enquire.

### Clamps



F234

#### Application

This clamp enables to establish a connection between the earth rod and the conductor.

Code	Designation	Nominal rod diameter (mm)	Maximal conductors section (mm²)	Screw	Weight (kg)	Sales unit
F234	CONNECTION CLAMP ROD DIAM 12.7 + 14 UNTHREADED	14 - 16	35	M8	0.050	50

### Bare copper cable



U05X



The copper cable is available:  
- in other dimensions  
- in insulated version

Please enquire

Code	Designation	Section (mm²)	Number of strands	Strand diameter (mm)	Weight (kg/km)
U051	BARE COPPER CABLE 16mm²	16	7	1.67	138
U052	BARE COPPER CABLE 25mm²	25	7	2.09	216
U053	BARE COPPER CABLE 29mm²	29	19	1.40	250
U054	BARE COPPER CABLE 35mm²	35	7	2.48	304
U055	BARE COPPER CABLE 50mm²	50	19	1.76	415

### Connectors



U00X



U02X

#### Application

These connectors establish a mechanical and electrical connection between two conductors to guarantee the equipotentiality of the system, to make a tap connection or to fix a severed conductor.

Code	Designation	Main conductor (mm²)	Secondary conductor (mm²)	Weight (kg)	Sales unit
U003	"C" SHAPE CONNECTOR 25-6	10 - 25	4 - 6	0.012	10
U004	"C" SHAPE CONNECTOR 25-10	16 - 25	4 - 10	0.012	10
U005	"C" SHAPE CONNECTOR 25-25	16 - 25	16 - 25	0.017	10
U020	JUMPER CLAMP 6-16mm²	6 - 16	6 - 16	0.028	100
U021	JUMPER CLAMP 16-50mm²	16 - 50	16 - 50	0.061	100



U031



U034



U035



U036

#### Application

This earth system disconnection kit as well as these cutting blades allow the opening of the earth circuit in order to perform an earth resistance measure.

Code	Designation	Conductor section min (mm²)	Conductor section max (mm²)	Weight (kg)	Sales unit
U030	TUBULAR LUG 25-29	25	29	0.020	50
U031	EARTH SYSTEM DISCONNECTION KIT 25-29	25	29	0.060	20
U034	"T" SHAPE GROUND CUTTING BLADE	10	35	0.180	10
U035	HIGH GROUND CUTTING BLADE	16	35	0.310	3
U036	LOW GROUND CUTTING BLADE	16	35	0.150	3

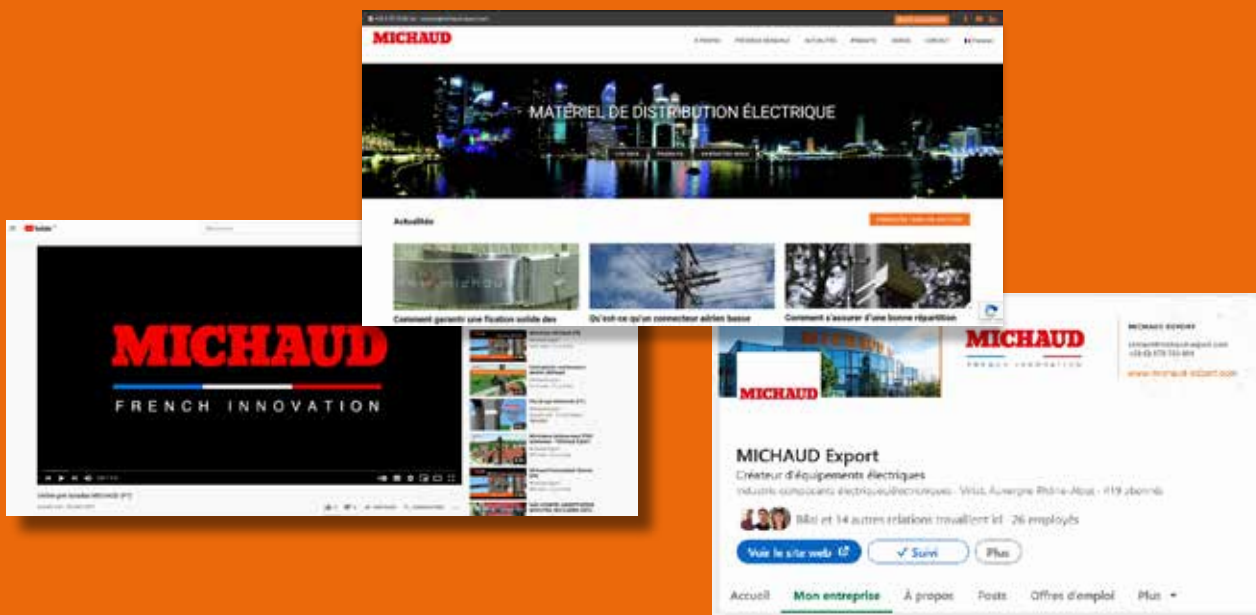

Découvrez notre site Internet  
[www.michaud-export.com](http://www.michaud-export.com)

Expert international de la distribution électrique, **MICHAUD** conçoit, développe et met en place des systèmes fiables réduisant les opérations de maintenance sur les réseaux de distribution.

En architecte de votre solution, l'entreprise s'appuie sur l'innovation perpétuelle et le savoir-faire reconnu des 250 collaborateurs du **Groupe MICHAUD**, spécialiste des appareillages électriques et éléments de raccordement.

### **MICHAUD Export**

499, Rue du Revermont  
ZAC La Cambuse  
01440 Viriat

France

Tél +33 (0)9 70 75 50 24

[contact@michaud-export.com](mailto:contact@michaud-export.com)

[www.michaud-export.fr](http://www.michaud-export.fr)

# MICHAUD