



2019/2020

Access to energy and fraud-preventing

Solutions to simplify and secure
electrical distribution

Catalogue
Energy controlling

MICHAUD
Export 



The French Group Michaud, has been designing, qualifying, producing and selling electrical equipment and connection systems for over 60 years.

According to the international standards, **Michaud Export** designs and develops energy distribution solutions. The product range is focused on two fields of expertise:

Michaud Export
in a few words:

- Reliability**
- Support**
- Adaptability
- Quality**
- Innovation
- Expertise**
- Reactivity
- Experience**
- Listening

- **Low Voltage Network:** to connect and protect the overhead and underground electrical lines ;

- **Energy Controlling:** to manage and offer easy access to electricity.



Creator of innovative solutions



Partner for access to energy

As a **technical expert in low-voltage networks**, Michaud focuses R&D on innovative solutions.

One-quarter of the world's population does not have access to energy, being a factor for economic development.

Thanks to an **engineering Department dedicated to international business**, Michaud Export provides support to Power Utilities in their grid expansion projects.

In this environment, Michaud Export offers a true **support approach** to evaluate the situation and to propose optimal electrification systems.

From protection to connections, many **innovative solutions** are already used in major Power Utilities around the world.

In order to meet the challenges of sustainable development, Michaud Export offers a complete products range dedicated to **Energy Controlling** in rural and suburban environments, enabling everyone to have access to electricity.



250
staff members



10

establishments
Europe,
North Africa,
Asia

Certified since



8 to 10%
of turnover
invested in R&D

1

Accredited
Test Laboratory



3
Engineering departments

* Accreditation n° 1-0579 available on www.cofrac.fr

From R&D to after-sales service, **Michaud Export**, as a Michaud subsidiary, has full mastery of its value chain, ensuring high-level quality and service worldwide.



MIRELEC

Mirelec is a Michaud brand, dedicated to low voltage electrical distribution equipment.

The brand offers **European quality** products and solutions at a **price matching emerging markets expectations**.



The development of electrification in Africa is essential to support the economic growth of the continent and to reduce poverty in rural and peri-urban areas. African governments are aware of it and place regularly national power companies at the heart of development strategies. The major challenges for these companies will be to meet the continent's economic and demographic challenge tomorrow, to make current and future investments profitable and thus achieve their electrification objectives.

Cost optimization



Adaptation to the local context



Sustainability of systems



Population - Sub-Saharan Africa

Evolution of the population

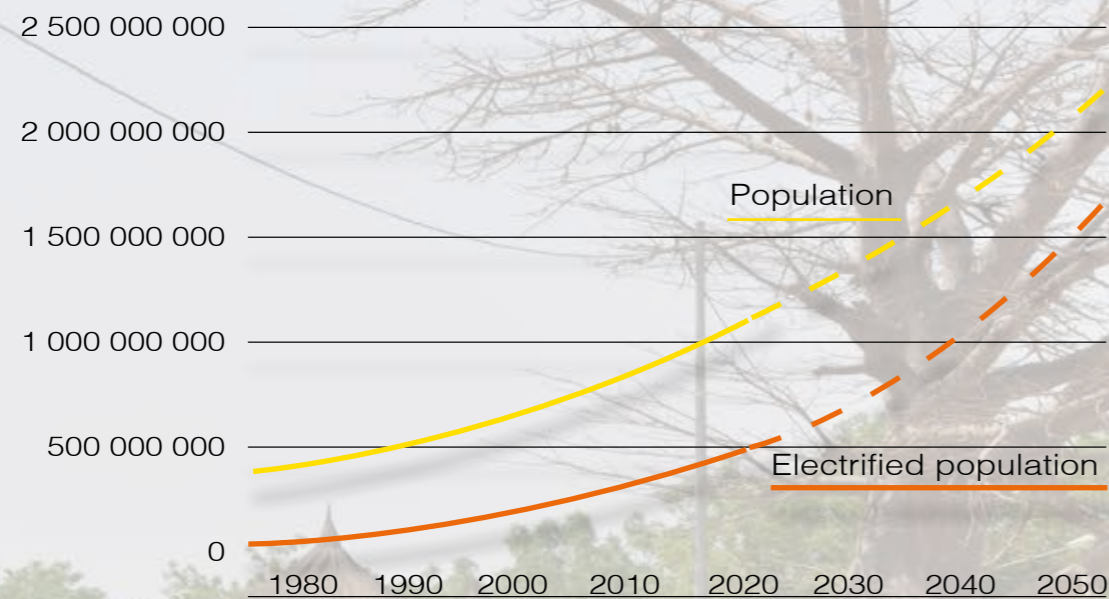

Data : World Bank and estimation trend until 2050.

In order to support population growth in matter of electrification, substantial investments will be needed for energy production, transmission and distribution. Thanks to the financial involvement of international organizations such as the World Bank, projects can be undertaken. Over the period 2014-2018, the World Bank has released \$ 5 billion for projects in energy access.

However, the current funds will not be enough to cover all needs and follow the upward trend. It is therefore necessary to support utilities with complementary solutions to help them electrify rural areas and secure revenues over the long run.

Networks safety

Michaud offers solutions to significantly significantly the levels of **non-technical losses** through the cleaning of electrical distribution networks. As a result, network security, profitability and sustainability are improved. Working on **network efficiency** is a major challenge and requires the involvement of all stakeholders, especially installers. Michaud supports its customers with training sessions dedicated to fitters in order to ensure the proper installation of equipment and avoid early damage.

Installations efficiency

Michaud Export offers solutions which adapt to **the specific context of rural electrification**, from network protection to energy management. This range of products meets local expectations while ensuring the most accurate sizing of equipment. Utilities **handle costs and resources** and ensure a reliable electrification model.

Through its solutions, Michaud Export participates in a reliable, economical and sustainable electrification model.

Summary

Extension

Rehabilitation

Management

Distribution

Protection

Extension

Rehabilitation

Management

Distribution

Protection

Fraud preventing

Network extension

Fraud preventing service cable	p.16
Accessories for fraud preventing service cable	p.18
Aerial connection box 8 outlets	p.20

Network rehabilitation

Mini switch	p.26
Aerial connection box 3 outlets	p.28
Fraud preventing system	p.30

Access to energy

Management

Energy manager	p.40
Accessories for energy manager	p.42
Load limiter	p.44
Meter cabinet RE for IGA's	p.46
Modular boxes	p.48

Distribution

Aerial service cable	p.52
LV A.B.C cable	p.54
Aerial accessories	p.56
Stainless steel strap	p.62

Protection

LV network fuse protection	p.66
Cartridges	p.68
Earth system	p.70



Fraud preventing

Fraud preventing

Network extension

Fraud preventing service cable	p.16
Accessories for fraud preventing service cable	p.18
Aerial connection box 8 outlets	p.20

Network rehabilitation

MINI-SWITCH	p.26
Aerial connection box 3 outlets	p.28
Fraud preventing system	p.30

Fraud preventing

With a growing consumption in electricity consumption in the coming years, the major challenge for utilities is **to be able to meet the increase of the demand** while maintaining an objective profitability. However, electrical networks suffer high losses, impacting the financial resources of companies.

To compensate this lack of bailout resources, public bailouts and price increases are sometimes applied. These very unpopular decisions tend to encourage the development of fraud and thus fuel the vicious circle of non-technical losses. **Securing facilities is a better strategy for achieving a positive financial impact.**

Michaud Export's solutions

To create a control and cut-off spot outside the premise



To remove illegal connections on the lines



Use theft-proof products



Case of the Sub-Saharan Africa

Evolution of electricity production

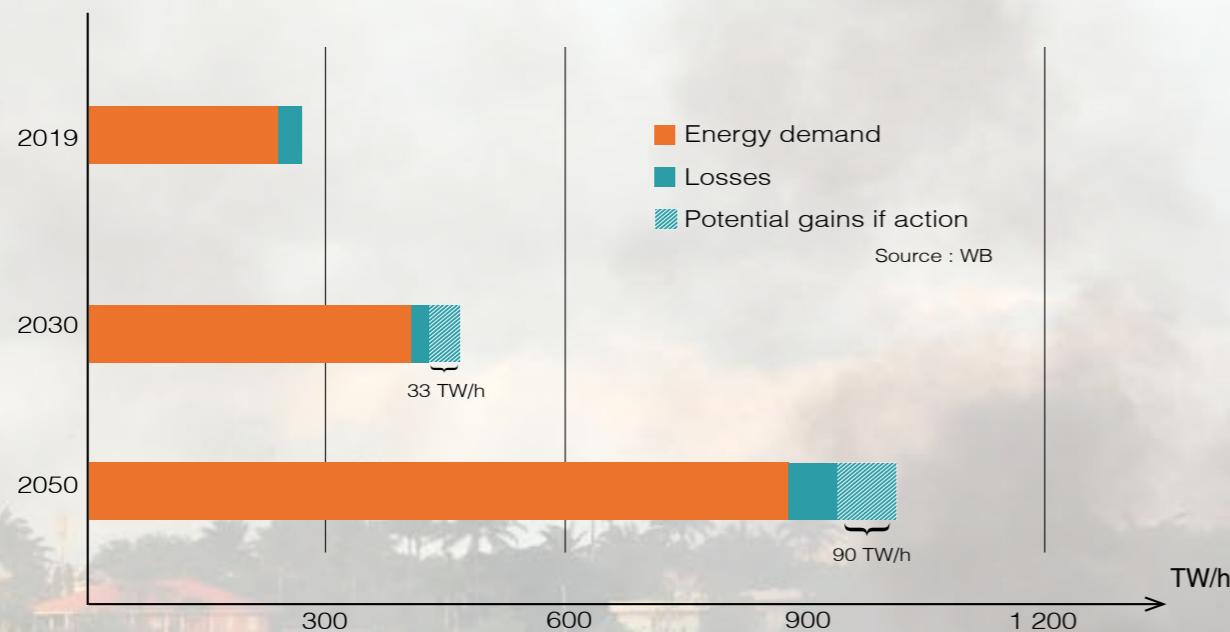

On this graph enlightens that in 2018, about 260 TWh were generated by the various electricity companies in the region. Of this amount, more than 33 TWh were lost during the production, transmission and distribution of energy, or 12.7% of the loss. Following current trends, by 2050, no less than 160 TWh should be produced in pure financial loss. This is the equivalent of 23 nuclear reactors. By optimizing transmission and distribution networks, over a 30-year period, **the annual gains could be close to 90 TWh, or 13 nuclear reactors.**

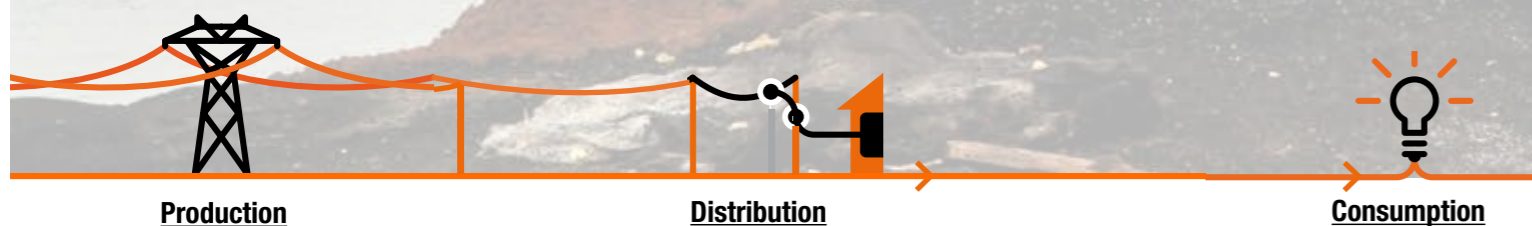

Technical losses

Any electrical network is subjected to a normal operating loss rate, due to the transformer efficiency rate or line losses on the cable. If reducing these phenomenon is difficult, **work on the proper use** of the equipment can help eliminate malfunctions:

- Material not adapted to the expected use
- Aging and deficient material

With better training of teams on the field, as well as a proper use of the product adapted to the environment, utilities could extend the service life of the facilities. **Improving the quality of the network** is the first step to realise savings.

Non-technical losses

The second cause very expensive for power companies, is the fraud on the electrical networks at the level of the connections. Through its experience and thanks to a close collaboration with the utilities, Michaud has identified **four sources to non-technical losses**:

- Subscriber's manipulation on the meter and circuit breaker
- Pricking out upstream from the meter
- Illegal connection
- Equipment theft

With equipment designed to reduce this phenomenon, savings can be made very quickly and allow companies to become profitable and thus enter **a virtuous circle of development.**

« It is 3 times less expensive to save 1 kWh of electricity by improving the electricity grid efficiency rather than to invest in new production means for the same 1 kWh. »



Zoom on pre-payment

Protecting the facilities against fraud becomes essential especially in a context where prepaid meters are more and more present. This efficient payment solution for the power company makes it difficult to manipulate the meter, and **tends to deport fraudulent operations on the service cable**. It is therefore necessary to support the expansion of pre-payment with equipment to prevent non-technical losses.

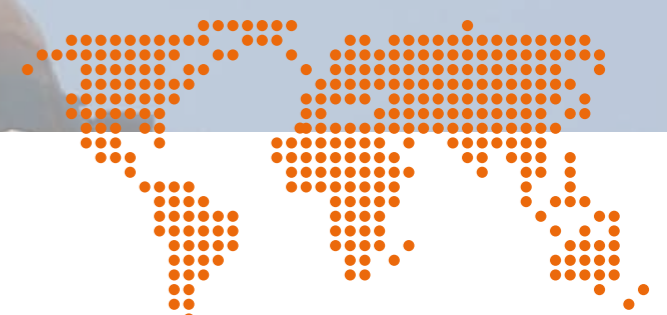
**Secure
new connections****Issues ?**

In the case of new electrification projects, electricity companies must be able to anticipate the installations security in order to prevent non-technical losses. By integrating the **fight against fraud** as soon as the specifications are defined, utilities opt for reliable solutions which are difficult to bypass and facilitate installation and maintenance.

Working in collaboration with African and Asian national power companies, Michaud has identified several key points to protect on new installations, from the network to the meter. The use of innovative technologies, to make connections, paired with automatic control systems ensure a **tamper-proof connection**.

Benefits ?

- + Meters shunt limited
- + Pirate connections restricted
- + Connectors theft for selling avoided
- + Fraudulent manipulations of the circuit breaker reduced

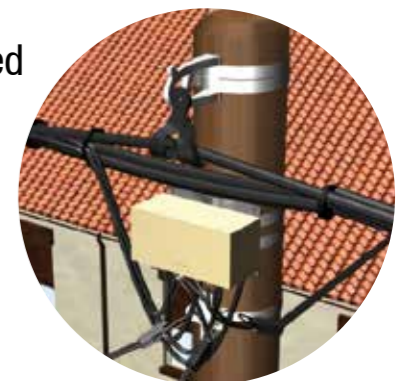

Solution for network extension

To **secure the network**, an **overhead service box** limits the use of connectors. Thus, the network is cleaner, more readable and frauds become easily detectable.

To **secure the connections**, the use of a **peripheral neutral cable** from the service connection box to the meter box, prevents illegal connections. In case of attempted fraud on this cable, a short circuit is created.

The fuse located in the **cutout sleeve** ensures the safety of the installation.

Located at the top of the pole, the cutout sleeve also creates a cutoff point. In needed, the customer can be disconnected from the network without modification of the connection and without tools.

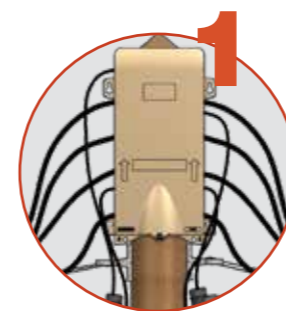
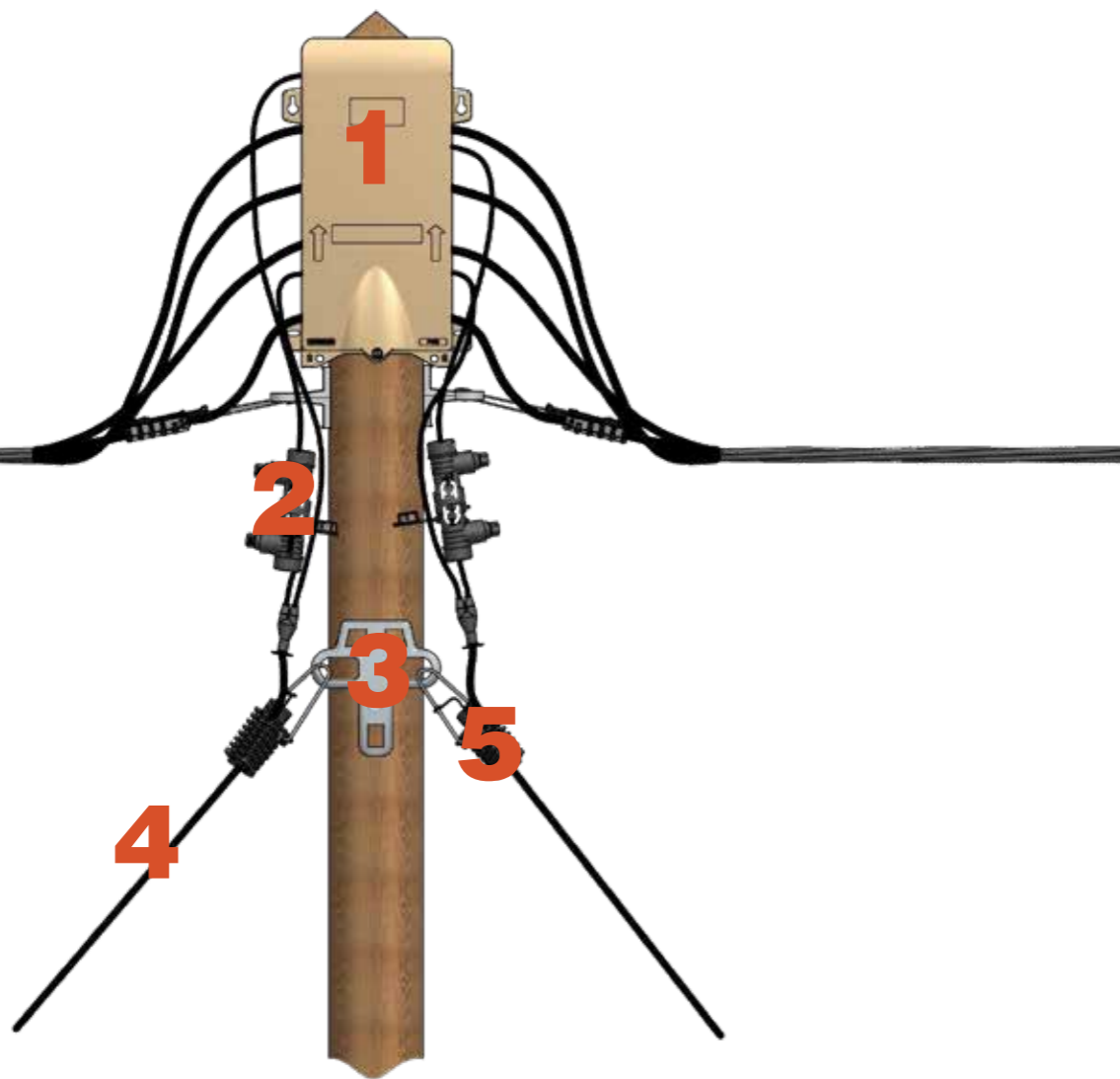

Service distribution box 8 outlets

The box allows to create a false cut and to tap up to 8 connections.

- + Connections protected from weather
- + Suppression the connectors and therefore less stress on the cable
- + Network readability

VOIR FICHE
FRAUD PREVENTING/ Extension/ Aerial connection box 8 outletsp20



Cutout sleeve + fuse cartridge

The cutout sleeve makes it possible to secure the connection by creating a break point at the top of the pole in case of a short circuit due to illegal tap connections.

- + Cut-off spot and protection at the top of the pole

VOIR FICHE
FRAUD PREVENTING/ Extension/ Accessories for fraud preventing aerial cablep18



6-points anchoring bracket

A 6-points bracket makes it possible to limit the fixing points on the pole.

- + Network readability
- + Mutualization of equipment

VOIR FICHE
FRAUD PREVENTING/ Extension/ Fulfilment kitp17



Peripheral neutral cable

Protects against illegal connections with an inaccessible phase, surrounded by a peripheral neutral.

- + Protection against illegal connections
- + Decrease of non-technical losses

VOIR FICHE
FRAUD PREVENTING / Extension/ Fraud preventing service cablep16

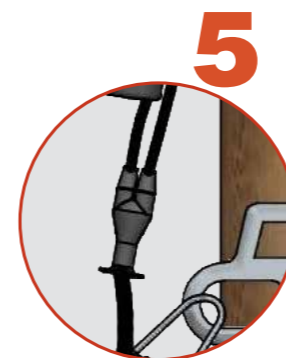

Fraud preventing cable fulfilment kit

Restores the neutral and the phase to make the connection to the network and to the meter.

- + Ensured watertightness

VOIR FICHE
FRAUD PREVENTING/ Extension/ Mechanical fixingp19

Fraud preventing service cable

MIRELEC

Application

The concentric insulated service cable is used for the connection between the low-voltage network and the premise. It is designed to limit fraud and thus to reduce non-technical losses thanks to a peripheral-neutral cable. Any unauthorised connection to this cable will create a short-circuit and will automatically cut off electricity supply. It is stretched overhead to a maximum range of 40m.



Description

- The single phase or three phases cable comprises :
 - One or three phase conductor(s) insulated in the central part
 - 1 peripheral insulated neutral conductor.
- Service voltage rate: is 600V.
- The conductor's core is made of aluminium.
- The insulation is made of cross-linked polythene.

The cables meet the criteria of the **IEC 60502** and **NFC 33 209** standard.

	U301	U307	U302	U308
Phase conductors section (mm ²)	1 x 13	1 x 16	3 x 20	3 x 25
Material of the phase insulation	XLPE	XLPE UV	XLPE	XLPE UV
Insulation phase thickness (mm)	≥0.8	1.2	≥0.8	1.2
Neutral conductor section (mm ²)	13	16	20	25
Material of neutral insulation	UV PE	XLPE UV	UV PE	XLPE UV
Insulation thickness of neutral (mm)	≥0.8	1.4	≥0.8	1.8
Operating voltage (V)	600	600 / 1000	600	600 / 1000
Maximum intensity (A)	45	60	60	90
Resistivity at 20°C (Ω/km) ≤2.5	0.045	1.91	0.045	1.2
Breaking strength (daN)	> 150	> 150	> 150	> 150

Code	Designation	Conditioning	Weight (kg)	Sales unit
U301	AERIAL SERVICE CONCENTRIC CABLE 13mm ² SINGLE PHASE	500m ring	80	1
U307	AERIAL SERVICE CONCENTRIC CABLE 16mm ² SINGLE PHASE	500m ring	100	1
U302	AERIAL SERVICE CONCENTRIC CABLE 20mm ² THREE PHASES	3000m ring	200	1
U308	AERIAL SERVICE CONCENTRIC CABLE 25mm ² THREE PHASES	750m ring	250	1

Fulfilment kit

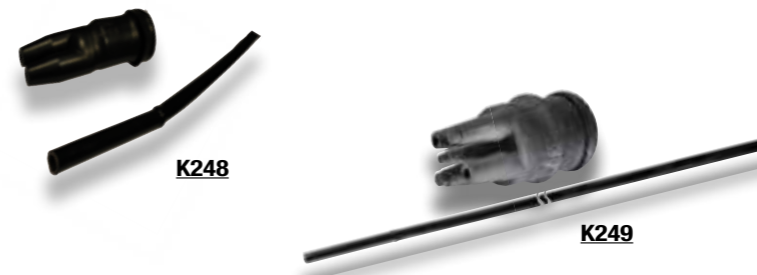

Application

These fulfilment kits enable to ensure the insulation and the sealing of the anti-fraud conductor, mainly for the neutral by reconstituting its insulation for the connection (the sheath is sheathed at its end).

Implementation

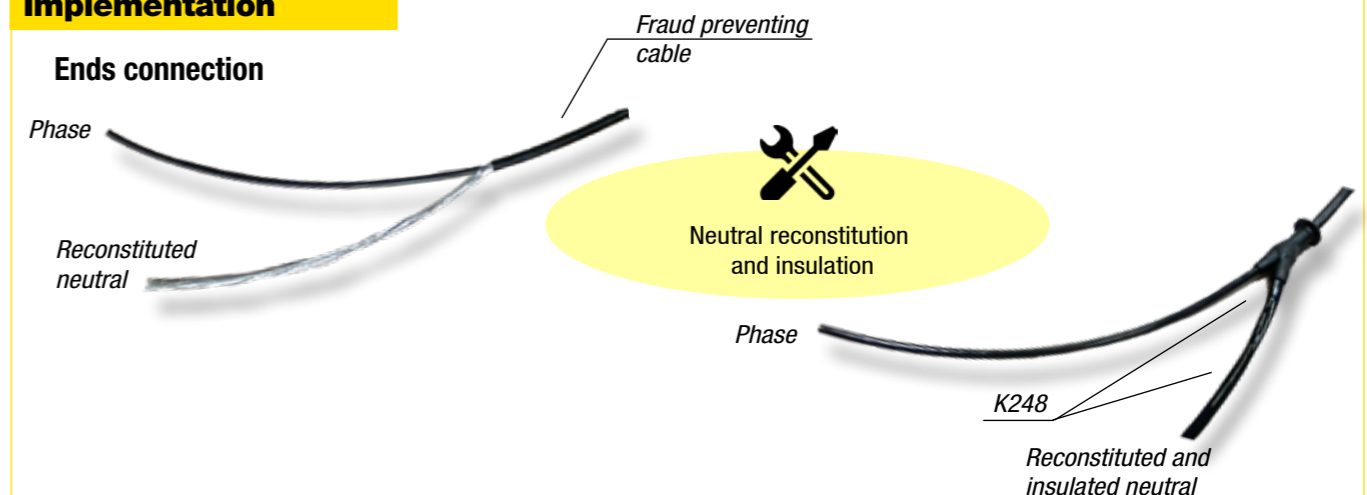

Code	Désignation	Match with	Weight (kg)	Sales unit
K248	FRAUD-PREVENTING CABLE FULFILMENT KIT - 13mm ² SINGLE PHASE	U301 and U307	0.040	1
K249	FRAUD-PREVENTING CABLE FULFILMENT KIT - 20mm ² THREE PHASES	U302 and U308	0.040	1

Tool for stripping



Application

This tool is used to strip the cable in order to reconstitute and isolate the neutral for connection.

Code	Designation	Sales unit
K311	CONCENTRIC STRIPPING PLIERS*	1

* The tool is available in several sizes to suit the cable section. Consult us.

Accessories for fraud preventing aerial cable

Cutout sleeve



MICHAUD

Application

This cutout sleeve makes it possible to secure the connection of the phase conductor and to protect the installation against electrical faults that may occur during illegal connections on the concentric cable. This cutout sleeve can receive a 22x58 fuse up to 100A or a neutral tube.

Description

- This cutout sleeve is installed on the customer service conductor.
 - This sleeve uses insulation piercing technology.
 - This sleeve receives 6-35mm² Al/Cu insulated conductor on both sides.
 - At the opening of the sleeve, the elastic tightening of the cartridge ensures that this fuse remains on the customer side, out of potential.
 - The single tightening is ensured by two shear head screws sealable after breaking.
 - The sleeve has a very good resistance to climatic conditions (humidity, temperature ...)
 - The cutout function is sealable
- This sleeves meets the criteria of ErDF French specification 69 40 070.

Code	Designation	Weight (kg)	Sales unit
K221	CUTOUT SLEEVE 63A (22x58) PIERCING 6-35	0.235	70

SEE SHEET
ACCESS TO ENERGY/Protection/Fuses

Mechanical fixing



Application

This anchoring assembly is designed for fixing low voltage service A.B.C (Aerial Bundled Conductors) with capacity of 2x6 to 4x25mm². The anchoring clamp is also available in an adjustable hook version.

Code	Designation	Weight (kg)	Sales unit
K310	ANCHORING CLAMP CONCENTRIC CABLE SINGLE PHASE	0.100	25
U508	ANCHORING CLAMP CONCENTRIC CABLE THREE PHASES	0.180	1
L304	FIXING CLAMP - PF25	0.010	100
F305	MULTIPLE ANCHORING BRACKET - CAM 25	0.220	100

Option :

Stainless steel strap is available for the mechanical fixing on a pole.

SEE SHEET
ACCESS TO ENERGY / Distribution / Tape

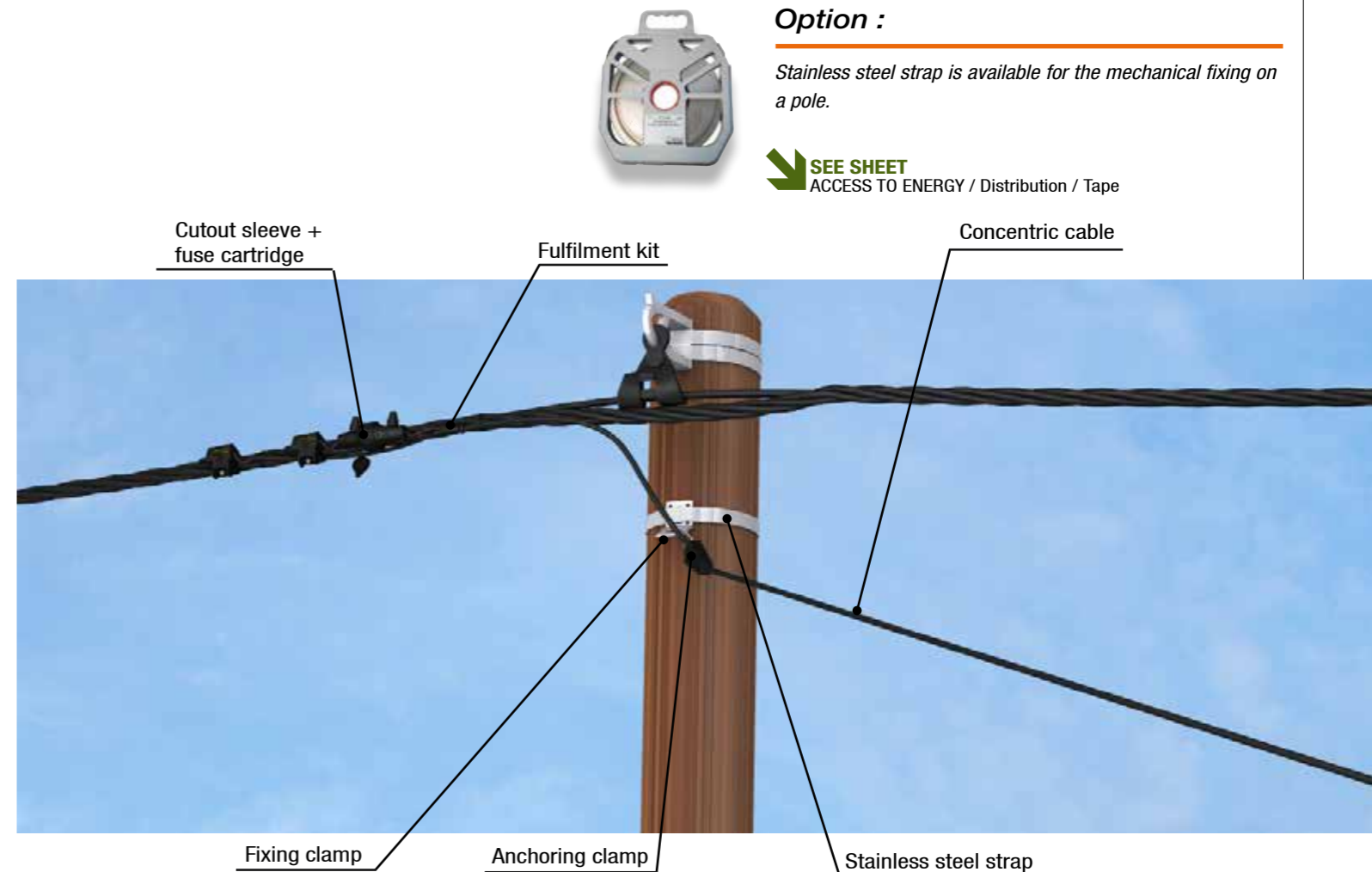

Service distribution box 8 outlets



P429

MICHAUD



Application

The box 8 outlets is designed to establish the junction of 2 overhead networks and the tap contact of 8 single phase or 4 three phase connections maximum. The box can be installed on a facade or a pole. It can also be used at the end of the network.



The benefits:

- + Perform single phase or three phases connections
- + Better spread charges on the network, thanks to the connections visibility
- + Reduce the number of connectors (safer network organisation, strengthened fraud-prevention)
- + Improve the network readability (removal of the "spider's web" effect)
- + Check the potential at the connection terminals (with a test probe)
- + Guarantee the network durability (better resistance to corrosion and humidity)
- + Make the operation easier (sliding cover with stop when used in open mode)
- + Guarantee a better fitters safety (electric shock risk limited)
- + Remove junctions between cables (making false regular cuts)

Description

- The 8 outlets box is equipped with 4 connection blocks. The network and connection terminals use insulation piercing technology.
- Each connection block is accessible at the touch of a voltage tester.
- The inlet and outlet of the conductors are realised by elastomer seals.
- The cover is closed by 1 captive stainless steel screw with spring to facilitate the release. An integrated device allows the sealing of all and possibly padlocked.
- The terminal separators in the box allow the connection of the conductors in any order.
- The degree of protection of the enclosure is IP33. The lid open, the degree of protection of the active parts is IP2X.
- The box can be delivered (optional) with a non-corrodible metal fixing plate. The rigidity of this plate allows laying on non-flat surfaces.
- The connection can be realised under voltage but without load.

This box meets the criteria of **HN 62-S-33** and **EN 50483-5** standards.

Installation

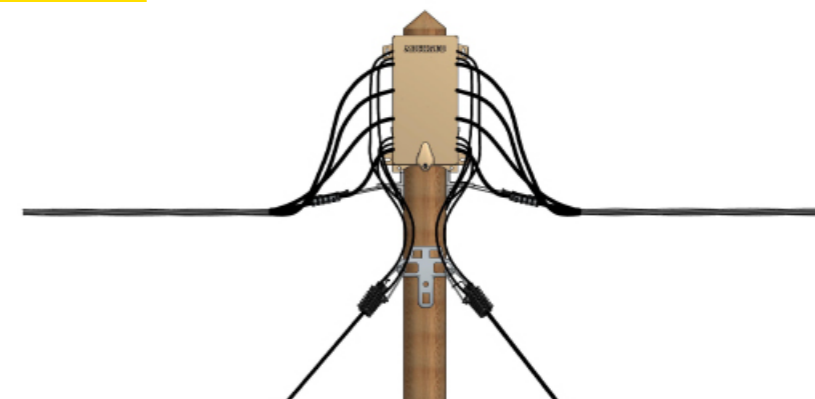

	INLET	OUTLET	
	Network	Network	Service
Capacities	16-95 mm ² Al	16-95 mm ² Al	6 Cu - 25 mm ² Al/Cu
Technology	Insulation piercing	Insulation piercing	Insulation piercing

Code	Designation	Weight (kg)	Sales unit
P429	SERVICE DISTRIBUTION BOX 8 OUTLETS	2.000	1

Variant

The aerial connection box is also available with 3 outlets.



P431
3 outlets
4 connection blocks

SEE SHEET
FRAUD PREVENTING / Rehabilitation / Aerial connection box

Zoom on the financial losses of the utilities

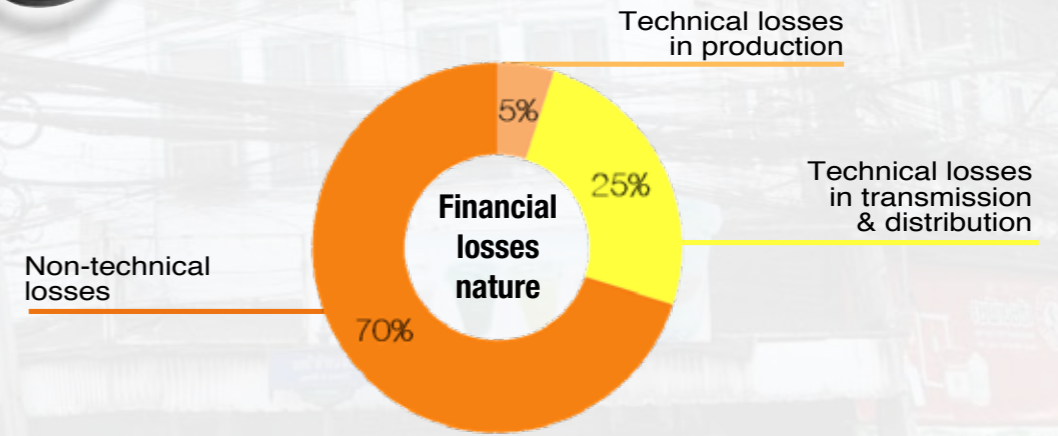

Stabilize the existing network



Issues ?

When a fraud preventing policy is launched for network improvement in order to reduce energy losses during transmission and distribution, the first step is to **rehabilitate existing facilities**.

With fraud preventing solutions installed on existing equipment, such as cable, **investments are minimized and benefits observed quickly**.

These solutions provide means to fight against some problems often encountered such as overconsumption not invoiced due to fraud upstream from meters and illegal connections on the lines.

Benefits ?

- + Network cleaned at a lower cost
- + Invoicing conform to consumption
- + Increase of the power companies incomes
- + Significant decrease of non-technical losses





A cut-off and control point at the top of the pole for existing connections

Cutout sleeve + MINI-SWITCH

The sleeve associated to the mini-switch allows to control of the energy consumption of the customer while creating a cut-off point at the top of the pole.

- + Utility intervention facilitated
- + Limitation of the current that can flow in the connection
- + Cut-off point in case of over-consumption

A distribution point to connect new customers on an existing network

Aerial connection box

The box secures the network by limiting the use of service connectors. It also makes the network cleaner making frauds more easily detectable.

- + Reduce the number of connectors
- + Protection of connections against bad weather
- + Network readability

Sleeve and mini-switch

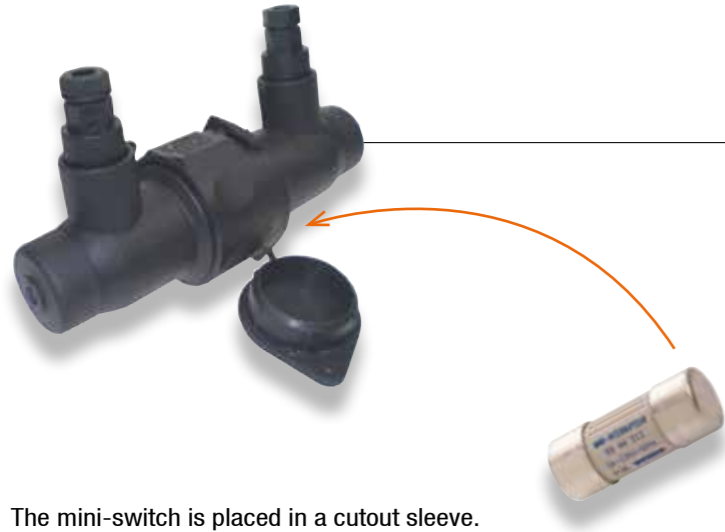

The mini-switch is placed in a cutout sleeve.

MICHAUD

Application

This mini-switch limits to a certain intensity the current that can circulate permanently in the connection and control the energy consumption of the customer.
Placed at the top of a pole or on an exterior facade in a cutout sleeve, it provides excellent **protection against fraud** mainly in case of bypass / shunt counter by limiting the consumption to the power subscribed.
The massive over-consumption related to fraud is thus reduced significantly.



Description

This mini-switch possesses :
Rating intensity limiting function on the principle of bimetal (thermal bimetallic strip):

- Caliber: 5A, 10A, 15A, 20A
- Size: 14x51mm, 22x58mm, T00
- Reversibility threshold: 45A or 60A depending on gauge.

- Circuit breaker fuse fonction (AD) : power of cut: 20kA.
- Endurance: from 5,000 to 15,000 cycles according the rating.

A three phases version is also available (Fuse Switch Disconnecter + fuses).

SEE SHEET
ACCESS TO ENERGY / Protection / Protection en tête de réseau BT

Principle of use

Example of a mini-switch 10A functioning.

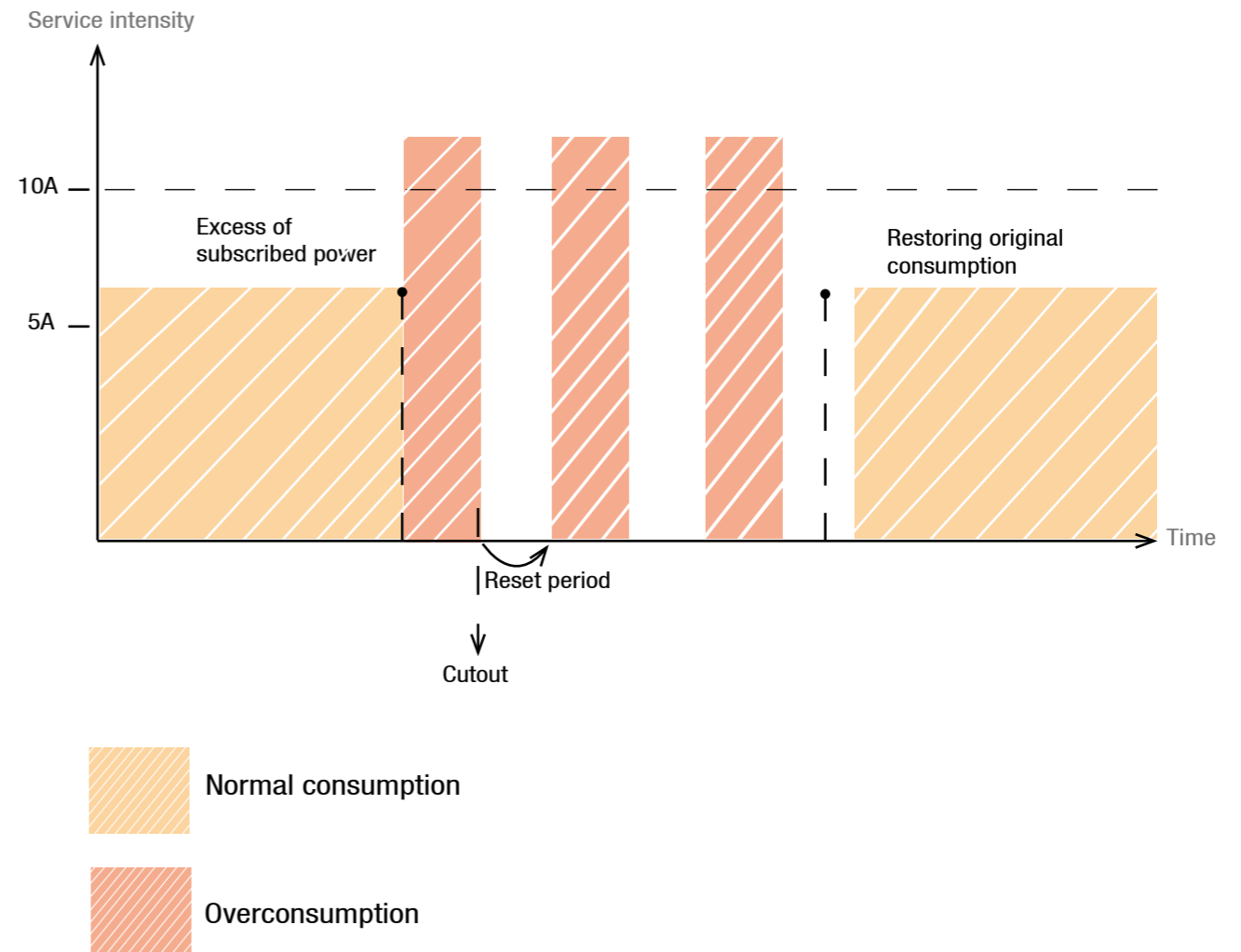

Code	Designation	Weight (kg)	Sales unit
Size 14x51			
P135	MINI-SWITCH 5A 14x51	0.030	10
P142	MINI-SWITCH 15A 14x51	0.030	10
Size 22x58			
P136	MINI-SWITCH 5A 22x58	0.040	10
P126	MINI-SWITCH 10A 22x58	0.040	10
P143	MINI-SWITCH 15A 22x58	0.040	10
P146	MINI-SWITCH 20A 22x58	0.040	10
Size T00			
P137	MINI-SWITCH 5A T00	0.110	10
P144	MINI-SWITCH 15A T00	0.120	10

Aerial connection box



P431



MICHAUD



Application

The box makes it possible to establish up to 6 single phase connections or up to 3 three phases connections at one point of the low voltage aerial bundled network. It can be installed on a façade or a pole. It can also be used at the network end.

Description

- The colour of the enclosure is ivory.
- The box is equipped with 4 connection blocks (1 neutral + 3 phases). The "neutral block" comprises one inlet and 6 outlets: each "phase box" comprises one inlet and 3 outlets. Network and Service terminals use either the insulation piercing technology or the stripping technology. The connection blocks are linked 2 by 2 by linking bars.
- Each connection block is accessible with the contact pin of a test probe.
- The inlet and outlet of the conductors in the lower part are performed through elastomer seal sockets.
- The box is delivered with an integrated anti corrosion metal fixing plate. The rigidity of this plate allows it to be installed on uneven surfaces.
- The cover is closed using 2 stainless steel screws.
- An integrated device enables the assembly to be sealed and possibly padlocked.
- The terminal separators inside the box enable the conductors to be connected in any order.
- The degree of protection of the enclosure is IP43 (according to **NF EN 60529**).
- When the cover is opened, the degree of protection of the live parts is IP2X.
- This box meet the acceptance criteria of the **HN 62-S-33** standard.

The benefits :

- + **Perform multiple single phase or three phases connections**
- + **Better spread charges** on the network, thanks to the connections visibility
- + **Guarantee the network durability** (better resistance to corrosion and humidity)
- + **Remove the connectors** (safer network organized, fraud-preventing strengthened)
- + **Disconnect subscribers easily** (network cable unimpacted, possibility to re-use connectors)
- + **Check the potential at the connection terminals** (with a test probe)
- + **Guarantee a better fitters safety** (electric shock risk limited)

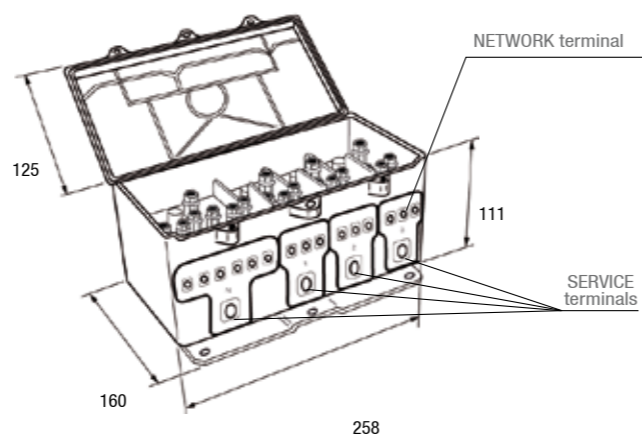

Implementation

Caution: the connection is not designed to withstand a mechanical strength on the conductors, which must be anchored. The maximum flow power is 110kVA.

	P 431	P 432
"NETWORK" terminals	<ul style="list-style-type: none"> • "NETWORK" terminals : Insulation piercing Capacity: 35mm² - 150mm² Al or Cu <ul style="list-style-type: none"> - Insert the conductor fully through the corresponding seal socket up to the stop. - Tighten the screw until the shear head breaks. - Use a wrench with 17mm hexagonal socket only. 	<ul style="list-style-type: none"> • "NETWORK" terminals : Stripping Capacity: 35mm² - 150mm² Al or Cu <ul style="list-style-type: none"> - Strip the conductor over a length of 90mm. - Brush the conductor with neutral grease. - Insert the conductor fully through the corresponding seal socket up to the stop. - Tighten the screw until the shear head breaks. - Use a wrench with 17mm hexagonal socket only.
"SERVICE" terminals	<ul style="list-style-type: none"> • "SERVICE" terminals : Insulation piercing Capacity: 10mm² - 35mm² Al or Cu 16M - 50M Al <ul style="list-style-type: none"> - Insert the conductor fully through the seal socket up to the stop. - Tighten the screw until the shear head breaks. - Use a wrench with 10mm hexagonal socket only. 	<ul style="list-style-type: none"> • "SERVICE" terminals : Stripping Capacity: 6mm² - 35mm² Al or Cu 16M - 50M Al <ul style="list-style-type: none"> - Strip the conductor to be connected over a length of 30mm. - Brush it with neutral grease. - Insert it fully through the seal socket up to the stop. - Tighten the screw until the shear head breaks. - Use a wrench with 10mm hexagonal socket only. - If reused, the conductor must be cut and stripped again. The recommended torque is 10Nm with an adapted spanner.

Code	Designation	Network terminals	Service terminals	Weight (kg)	Sales unit
P431	INSULATION PIERCING AERIAL CONNECTION BOX 3 OUTLETS	Insulation piercing	Insulation piercing	2.880	1
P432	STRIPPING AERIAL CONNECTION BOX 3 OUTLETS	Stripping	Stripping	2.780	1



Video implementation available on the website www.michaud-export.fr (Documentation tab> Implementation videos)



Solution recommended by
Michaud Export

Single phase

13 mm² cable



16 mm² cable



1 Cable

Fulfilment kit



Connection box



Connector



2 Connectors

Sleeve



Mini-switch



Fuse



3 Protection

Anchoring clamp



Multiple anchoring



Simple anchoring



4 Anchoring

Solution recommended by
Michaud Export

Three phases

20 mm² cable



25 mm² cable



Three phases fulfilment kit



Distribution box



Connector



Fuse switch disconnector + Fuses



Cutout sleeve + Fuse



Anchoring clamp



Multiple anchoring



Simple anchoring



Access to energy

Access to energy

Management

Energy manager	p.40
Accessories for energy manager	p.42
Load limiter	p.44
Meter cabinet RE for IGA's	p.46
Modular boxes	p.48

Distribution

Aerial service cable	p.52
LV A.B.C cable	p.54
Aerial accessories	p.56
Stainless steel strap	p.62

Protection

LV network fuse protection	p.66
Fuses	p.68
Earth system	p.70



Management

Management

Management

In Kenya, 85% of household customers account for 25% of energy sales. In these conditions, an economical and autonomous management system can improve profitability and encourage access to energy.

The **energy flat fee** invoicing simplifies customers management by lowering operating and maintenance costs.

For Income Generating Activities (IGAs), a solution with simplified metering enables to reduce purchase costs for the operator.



Distribution

Optimising cable cross-sections for actual consumption is an effective way to lower the costs of a project.

With a 2x6mm² cable cross-section, 30A intensity and a reach of 40m, voltage drop is below 2%.

The 2x6mm² cable and corresponding accessories ensure implementation savings up to 30% for the operator.



Protection

In a context where maintenance costs are very high on electrical networks, materials protection is one of the main way to guarantee the equipment **sustainability**.

The network head-end is a key point of a LV infrastructure. Michaud Export proposes an economical alternative technology using fuses. Their high breaking capacity guarantees the installation security.

In addition, electrical networks must be protected with earth systems for people and goods safety.



Distribution

Distribution

Protection

Protection

Access to energy

Simplified management of the consumption



Issues ?



In developing countries and more particularly in Sub-Saharan Africa the electrical network according to its infrastructure usually only reaches 20% of localities. This deficiency does not enable an **economic, and social development** of those territories.



Knowing about this context and being focused into electricity distribution toward the end customer, Michaud designed **innovative solutions to optimize connection and business management**.



Operating and selling difficulties of the electrical service in rural areas, sometimes isolated, have been integrated into a global thinking. That is why Michaud's innovations take into account **every components of the connection, from cable to customer interface**, through **solutions for consumption management**.

Benefits ?

- + Support for economic development
- + Minimize implementation, maintenance operating costs
- + Simplify customers' management



Flat fee invoicing

How does the flat fee invoicing system work ?

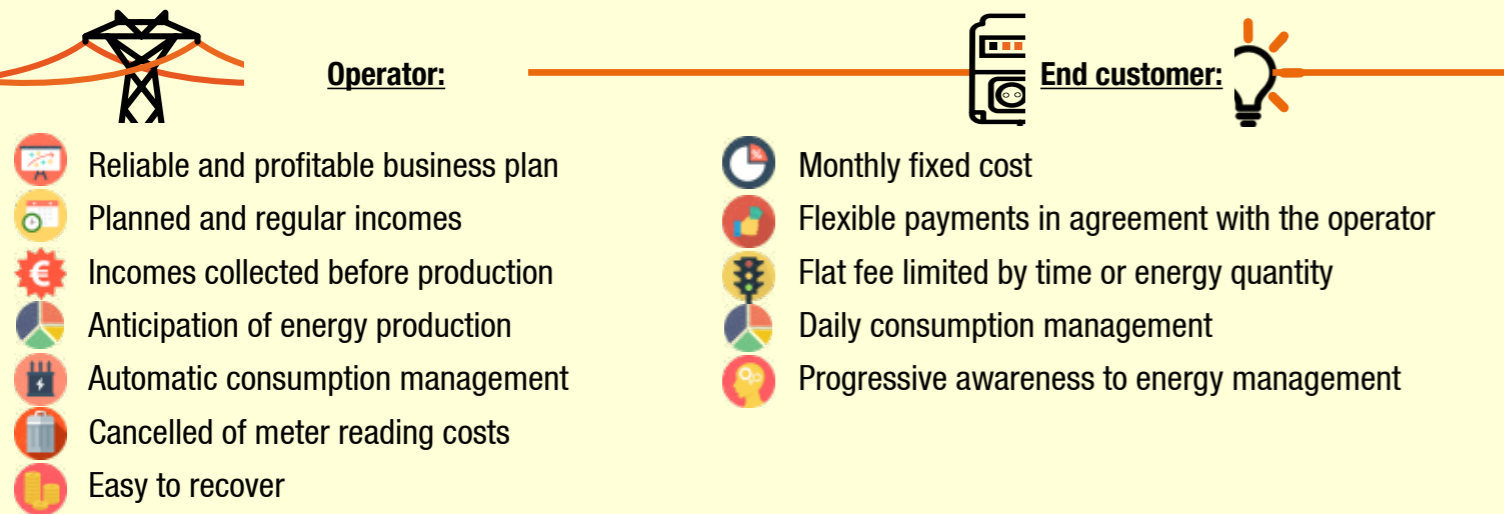

Flat fee system: worthy advantages

- + Cash flows optimised
- + Limited recovery faults
- + Easy going investments and financing

The flat fee invoicing system allows the operator to collect incomes **before** engendering production costs.

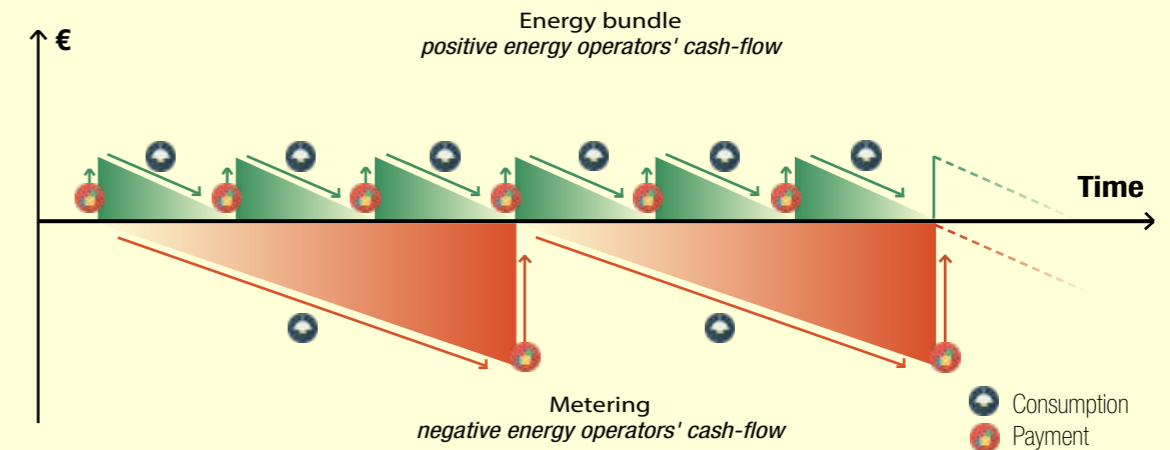

Financial advantage: better cash flows management

How does the payment operate ?

In the rural electrification context, end customer's payment management is one of the major difficulties. The flat fee system brings some **flexibility to the operator** by offering various possibilities for payments. According to the economic and social environment of connected villages, customers can pay:

- through **mobile banking solutions**
- through **money transfer solutions**
- with **fiduciary money**

Depending on the end customers number, payments can be settled using a classic IT spreadsheet, easy to manage.

An adapted solution to rural electrification projects

With the **energy manager**, Michaud Export designed a solution which answers to this invoicing system. The energy manager can be set up according to the end customer contract and so frame the consumption.

The flat fee invoicing system remains the most suitable way for tiny consumptions.



Structural advantage: energy production anticipated

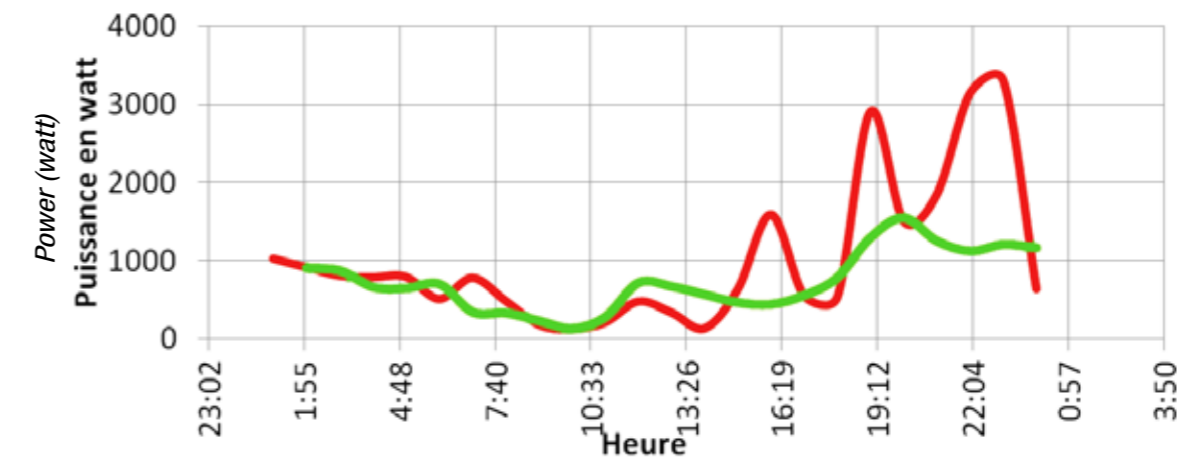

Daily consumption of a rural area village

- Before the energy managers installation
- After the energy managers installation

Thanks to an electricity consumption ceiling, the flat fee system enables to know the end customers' maximum consumption. The operator **anticipates production needs** avoiding network failures and demand peaks.

The flat fee invoicing system tends to standardize inhabitants consumptions. It is a **didactic system**, perfectly suitable for end customers electrified for the first time.

Energy manager



K497
cabinet version



K498
module version

MICHAUD

Application

The energy manager is provided with an electronic regulator, controlling power and managing energy automatically without user/operator intervention. It is perfectly suitable for flat fee energy invoicing. It replaces the meter and cancels the requirement of consumption reading. The cabinet can be installed outside thanks to the UV resistant IP34 property. It is designed for a single phase connection.

Description

The energy manager is programmable according to the criterias chosen by the operator :

MANAGEMENT MODE



Time

Allocated time quantity is adjustable down to the last hour



Energy



Allocated energy quantity is adjustable down to the last watt

SETTINGS



The energy manager setting can be performed on site

Power

Maximum instant power allowed (1500W.)

Transfer

Possibility to transfer the remaining time or energy quantity to the next period (1 period maximum)

Observation period

Period while allocated time or energy quantity is defined. This gives a daily or weekly control of the used energy (1 day to 1 week)

Shut down time after overage

Time during which energy is shutting down due to a power overage (up to 3600 seconds)

Accepted overage time

Time during which the maximum authorized instant power can be overcome (up to 60 seconds)

The energy manager is provided with 4 LED allowing to see the consumption progress through:

- an intuitive tracking method of colors
- the blinking LED speed

The settings can be modified according to flat fee contract set up by the operator, following households evolution.

Code	Designation	Weight (kg)	Sales unit
K497	PROGRAMMABLE ENERGY MANAGER CABINET 20 - 1 500W	0.360	1
K498	PROGRAMMABLE ENERGY MANAGER MODULE 20 - 1 500W	0.150	1

SEE SHEET
Modular cabinets: make up your own solution

To fit the environment, the module can be set in different holders, as the modular interface below. **Please enquire.**



Energy manager accessories

Configuration

PC kit

The kit comprises an USB key containing the configuration software and an USB cable to connect energy manager to PC.

It is the best solution for the operator to set the energy manager at the office before the installation. Moreover, it allows to program the different flat fees levels offered by the operators.



K499

Application

The energy manager configuration is performed through a software available on PC or tablet.
The last ten settings are kept in memory for a better suscriber follow up.



MICHAUD

Tablet kit

The tablet kit includes a safe bluetooth system (dongle) and a digital tablet.

It allows an easy access to the energy manager on site.



K488



Option :

The EM (K487) bluetooth extension is available.
Please enquire.



Code	Designation	Weight (kg)	Sales unit
K499	PC ENERGY MANAGER KIT	0.710	1
K488	PROGRAMMABLE ENERGY MANAGER BLUETOOTH DONGLE + TABLET	1.150	1

The connectors allow a safe phase and neutral connection thanks to a cutout function, protecting in this way the energy manager.

Connection

Application

To afford the connection of a single customer as part of a new installation, the energy manager can be associated to connectors.

Description



K224



K232

	Fuse IPC (K224)	IPC (K232)
Function	It is designed to offer safe phase connection and protect both of the electrical installation and the energy manager against electrical faults.	It is designed to offer a watertight and safe connection of the neutral conductor.
Technical specifications	<ul style="list-style-type: none"> - Cable sections: 16-95 / 6-16mm². - Insulation piercing technology. - Simultaneous tightening. - Potential free shear head screw. - Very good resistance to harsh weather (humidity, heat...). - IP2x during implementation - IP33 after installation. - Integrated and sealable cutout. - Fuse: size 10.3x38mm gG. 	<ul style="list-style-type: none"> - Cable sections: 16-95 / 2.5-35mm². - Insulation piercing technology. - Simultaneous tightening. - Potential free shear head screw. - Very good resistance to harsh weather (humidity, heat...).

Code	Designation	Weight (kg)	Sales unit
K223	FUSE CONNECTOR PIERCING 95/16	0.130	10
K232	CONNECTOR CBS / CT 95	0.130	30

For the fuses, **please enquire.**



Load limiter



Cabinet version



Module version

MICHAUD

Application

The load limiter is provided with an electronic regulator which controls intensity and manages power automatically without user/operator intervention. It is perfectly suitable for flat fee invoicing. It replaces the meter and cancels the requirement of consumption reading. The cabinet can be installed at the top of the pole or on the outside facade with the help of screws and strap. The cabinet resists to UV and to water or insect penetration (IP34D). Its cover closing can be sealed providing an excellent fraud protection. This cabinet limiter can receive a single phase connection with 2.5-16mm² cable sections.

Description

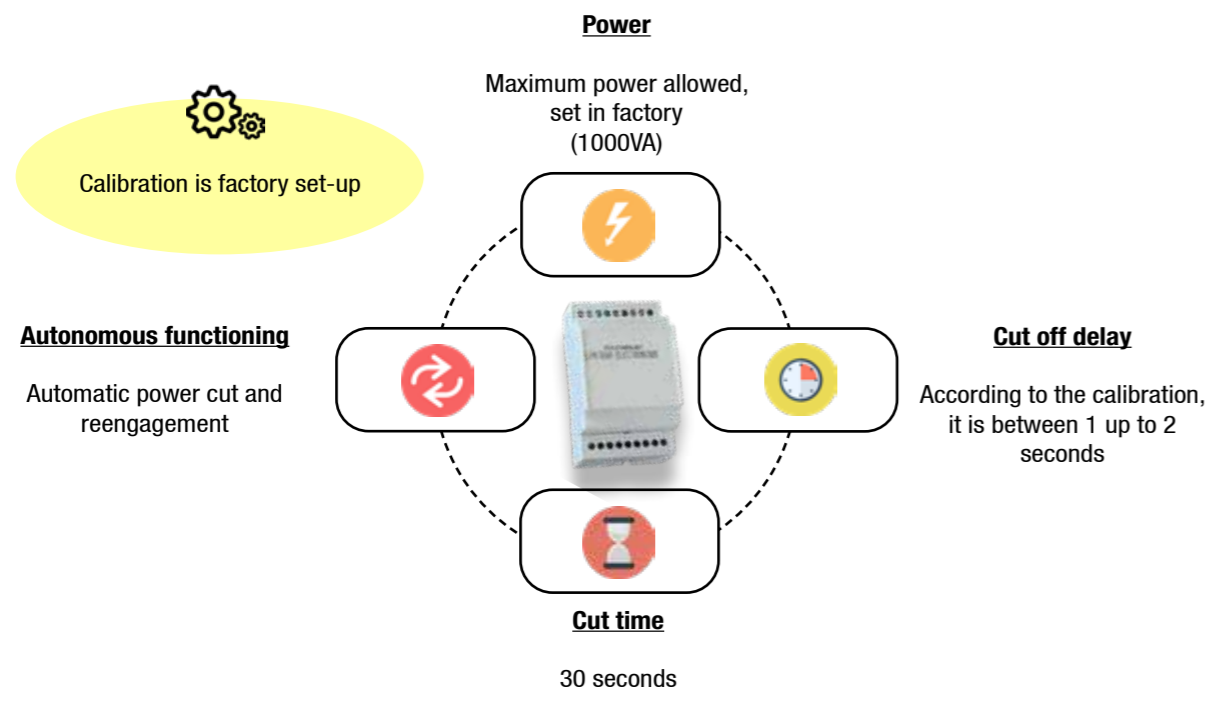

Code	Designation	Weight (kg)	Sales unit
K480	ELECTRONIC LIMITER CABINET 50-75VA	0.380	1
K481	ELECTRONIC LIMITER CABINET 75-250VA	0.380	1
K482	ELECTRONIC LIMITER CABINET 250-1000VA	0.380	1

Integrated version into modular interface

MICHAUD



Module Load limiter

Application

The load limiter module can be placed into an interface. It comprises a cutout and a differential circuit-breaker to ensure goods and people protection. It is equipped with an input through a cable gland for power supply and 2 outputs :
- an electrical outlet for simple access to energy
- a second output through a cable gland and a insulating screw joint for home wiring. The whole is pre wired and is suitable for a single-phase connection. Ideally, it can be installed inside the home or in an outdoor shelter.

Description

Envelop:

- Synthetic materials.
- Dimensions (LxWxD): 220(260)x150x120mm.
- Mounted / connected: cutout 10.3x38 (hidden) / differential circuit-breaker / modular electronic load limiter / earthing terminal block / power socket and black domino terminal.
- Cable gland at the bottom used to route power cables (2x6-16mm² - diameter 13 up to 18mm).
- Movable window on the front side making the access to modular devices easier.
- First outlet with power socket having closed protection cover IP54
- Second outlet with cable gland allowing leading-out cable (2x2.5mm² - diameter 5 up to 10mm).
- IP43 device with conductors.
- Fitted with precuts at the bottom enabling the fixing of the envelope with screws, on every kind of material.
- Anti-fraud: sealing possibility preventing access to the live areas.

Cut out:

- Disconnection: Phase and Neutral.
- Equipped with a fuse 16A gG 10.3x38mm.
- Hidden cutout, inaccessible from the user.

Differential circuit-breaker:

- Nominal current: 5A.
- Nominal voltage application: 230V / 240V, 50Hz.
- Breaking capacity: I_{cn} = 3kA.
- Differential sensitivity: I_Δ = 300mA.
- Breaking curve: type C.
- Differential breaking: instantaneously.

Power socket:

- Bipolar plug + earthing (type NF C 61-314).
- Female type.

Option :

As an alternative to the electronic load limiter, another interface is available with a 1A thermal limiter. (K832)

Please enquire.



Code	Designation	Weight (kg)	Sales unit
K811	CUSTOMER BOARD 50-75VA	1.000	1
K812	CUSTOMER BOARD 75-250VA	1.000	1
K813	CUSTOMER BOARD 250-1000VA	1.000	1

SEE SHEET
Modular cabinets : make up your own solution

Meter cabinet RE for IGA's

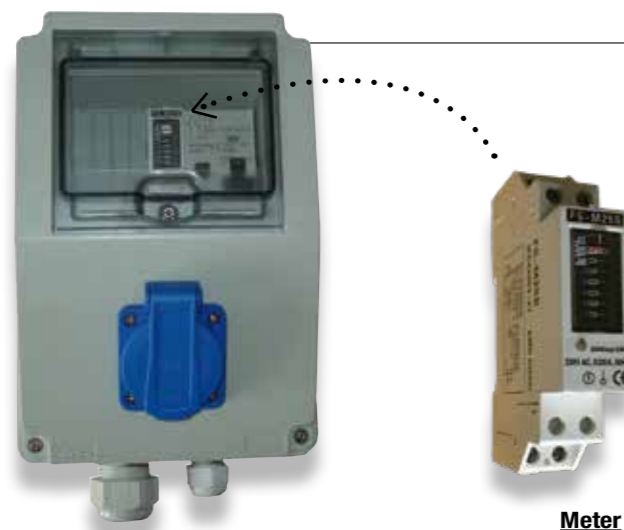

Meter

MICHAUD

Application

This 2 outputs meter cabinet is a solution perfectly suitable for Rural Electrification (RE) and particularly Income Generating Activities (IGA's).

It comprises an internal circuit breaker, a meter and a differential circuit breaker to ensure goods and people protection.

It is equipped with an input through a large cable gland for power supply and 2 outputs:

- An electrical outlet for simple access to energy,
- Second outlet through a smaller cable gland and black domino terminal for home wiring.

The whole set is pre-wired. Ideally, it can be installed inside the home or below a shelter.

Description

Envelop:

- Synthetic materials.
- Dimensions (L x W x D): 220(260)x150x120mm.
- Mounted / connected: cutout 10.3x38 (hidden) / meter / differential circuit-breaker / earthing terminal / power socket and terminal black domino terminal.
- Cable gland at the bottom used to route power cables (2x6-16mm² - diameter 13 up to 18mm).
- Movable window on the front side making the access to modular devices easier.
- First outlet with power socket having closed protection cover IP54.
- Second outlet with cable gland allowing leading-out cable (2x2.5mm² - diameter 5 up to 10mm).
- IP43 Device with conductors.
- Fitted with precuts at the bottom enabling the fixing of the envelope with screws, on every kind of material.
- Anti-fraud: sealing possibility preventing the access to the live areas.

Cut out:

- Disconnection: Phase and Neutral.
- Hidden cutout, inaccessible from the user.

Differential circuit-breaker:

- Nominal current: 1A, 3A, 5A, 10A or 15A.
- Nominal voltage application: 230V / 240V, 50Hz.
- Breaking capacity: I_{cn} = 3kA.
- Differential sensitivity: I_Δ = 300mA.
- Breaking curve: type C.
- Differential breaking: instantaneously.

Power socket:

- Bipolar plug + earthing (type NF C 61-314).
- Female type.



Meter:

- Single phase type meter of 1 module size (18mm width).
- Class of measure: 1.
- Voltage rate: 230VAc ±10%.
- Frequency: 50Hz.
- Maximal current: 30A.

Code	Designation	Weight (kg)	Sales unit
K851	METER CABINET 2.0 1A	1.000	1
K853	METER CABINET 2.0 3A	1.000	1
K855	METER CABINET 2.0 5A	1.000	1
K856	METER CABINET 2.0 10A	1.000	1
K857	METER CABINET 2.0 15A	1.000	1

Option:

As an alternative, the meter cabinet is proposed with one output (1.0), access to energy being possible only through the power socket on the front side.



Code	Designation	Weight (kg)	Sales unit
K841	METER CABINET 1.0 1A	1.000	1
K843	METER CABINET 1.0 3A	1.000	1
K845	METER CABINET 1.0 5A	1.000	1
K846	METER CABINET 1.0 10A	1.000	1
K847	METER CABINET 1.0 15A	1.000	1



SEE SHEET

Modular cabinets: make up your own solution



Modular cabinets : make up your own solution

To support you in the choice of your system, consult us.

Benefits ?

- + Customized solution
- + Wide range of customers' management
- + Possibility to combine different management modules
- + Several protection technologies
- + Components implemented in serie and/or in parallel

Gestion 1. Choose your cabinet

Individual cabinet

The transparent front door enables a clear readability of components like LED. Modules are fixed on DIN rail. It is implemented in a shelter or inside the premise.



Collective cabinet

The cabinet enables to gather equipment to optimize costs of several connections. Modules are fixed on DIN rail. It is implemented at the top of a pole.

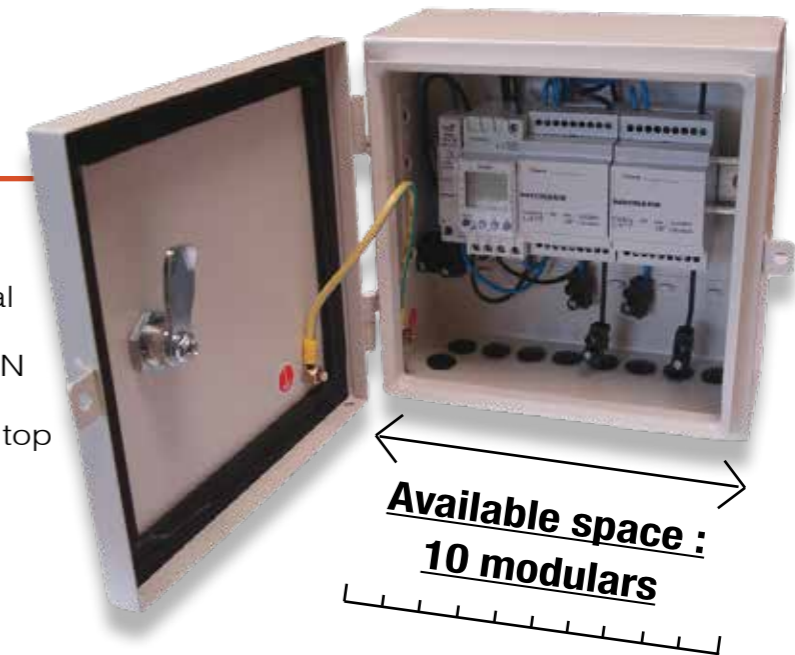

Gestion

2. Select your functions

Management

Protection

 Load limiter 3 MODULARS	 Thermal limiter 1 MODULAR	 Clock 2 MODULARS	 Energy manager 3 MODULARS	 Mechanical and electronical meters 1 MODULAR	 Cut-out 1 MODULAR	 Circuit breaker 1 MODULAR	 Differential cut-out 2 MODULARS
-------------------------------------------	---------------------------------------------	------------------------------------	---------------------------------------------	----------------------------------------------------------------	-------------------------------------	---------------------------------------------	---------------------------------------------------

Reliable and optimized electricity distribution



Issues



As a part of rural electrification programs, **electricity distribution costs** represent a significant budget and are often undervalued. In most cases, those additional charges are due to the transposition of traditional electrification models, without taking care of the economic, social and cultural context of developing countries.



Michaud proposes simplified solutions for low voltage connections, following international standards, from the HV/LV transformer aval post to the end customer. The result is **15% to 30% saving** enabling to connect more households and villages with the allocated budget !

Benefits

- + Costs reduction
- + Adaptation to local context
- + Optimized access to energy



Aerial service cable

IEC 60502



Michaud Export
6mm² optimized section
Exclusivity

MIRELEC

Application

This single phase or three-phase aerial cable is used for the connection between the low voltage network and the home. It is perfectly suitable for electrification applications in rural and suburban areas thanks to its optimized 6mm² section. It is stretched to a maximum range of 40m.

Description

- This single phase or three phase cable respectively consists of 2 or 4 twisted insulated conductors, phase(s) and neutral.
- Service voltage rate: 600V.
- Conductors core made of aluminium:
 - Conductors section: 6mm²
 - Diameter over core: 3.12mm
 - Number of strands: 7
 - Diameter of strands: 1.04mm
 - Mechanical strength of strands: 18.5daN/mm²
 - Minimum strain of strands: 1.2%
 - Step factor: 10 - 16
 - Step direction: right
- Conductors insulation made of polyethylene:
 - Nominal insulation thickness: 1.2mm
 - Minimum insulation thickness: 0.98mm
 - Diameter over insulation: 5.52mm
- Cable characteristics:
 - Phase identification: marking
 - Twist step factor: 25 - 60
 - Twist step direction: right
 - Twist weight: 75kg / km
 - Dielectric test / water: 2.5kVac / 1 min
 - Linear strength to 20°C: 4.5Ω/km
 - Maximum intensity in permanent capacity in the open air: 30A
 - Maximum temperature in service: 90°C
- This cable meets the acceptance criteria of the **IEC 60502** standard.

Code	Designation	Packaging	Weight (kg)	Sales unit
U300	AERIAL SERVICE CABLE 2x6mm ²	200m ring	15	1
U304	AERIAL SERVICE CABLE 4x6mm ²	200m ring	30	1



Other cable sections available.

Please enquire.

Accessories dedicated to the 6mm² cable

EN 50483 CE NF



L227

This insulation piercing connector is used to perform a tap connection from a network from 16 up to 95mm² with the 6mm² aerial service cable.

Code	Designation	Weight (kg)	Sales unit
L227	CONNECTOR CES/CT 95	0.060	200



L304

L306



U500

This anchoring clamp is used to fix 2x6mm² service cable between the pole and the home. It can be associated with the PF25 fixing clamp (L304) for implementation on a wall or a pole, thanks to a screw M10 (L306) or strap.

This accessory is used for supporting service network of type 2x6 up to 4x25mm².

K265



Code	Designation	Weight (kg)	Sales unit
U500	ANCHORING CLAMP 2x6mm ² - PA6	0.100	60
U500 4x6	ANCHORING CLAMP 4x6mm ² - PA4x6	0.120	60
L304	FIXING CLAMP - PF25	0.010	100
L306	SCREW M10	0.048	50
K265	BELT SUSPENSION WITH RING	0.020	25



SEE SHEET

ACCESS TO ENERGY / Distribution / Stainless steel strap



This tool is perfectly adapted to strip 6mm² section cables to facilitate wiring to equipment.

Code	Designation	Weight (kg)	Unit sale
F493	STRIPPING TOOL 6mm ²	0.150	1

Low voltage twisted insulated cable

Network



U096

MIRELEC

Application

This cable is used for low voltage electrical distribution (0.6 / 1kV, 50Hz). The cable comprises a neutral messenger which is twisted with the rest of the conductors. One or several street light conductors are possible, consult us.

Description

- This cable has a working temperature of -60 °C to + 50 °C.
- The minimum installation temperature is -20 °C.
- The maximum allowed conductor temperature is + 90 °C.
- The bend radius of curvature corresponds to 10 x diameter of the conductor.

Code	Designation	Diameter of the cable (mm)	Weight of the cable (kg/km)
U096-3x16+54.6	INSULATED LOW VOLTAGE CABLE 3x16 + 54.6mm ²	18	404
U096-3x25+54.6	INSULATED LOW VOLTAGE CABLE 3x25 + 54.6mm ²	21	495
U096-3x35+54.6	INSULATED LOW VOLTAGE CABLE 3x35 + 54.6mm ²	23	577
U096-3x50+54.6	INSULATED LOW VOLTAGE CABLE 3x50 + 54.6mm ²	26	702
U096-3x70+54.6	INSULATED LOW VOLTAGE CABLE 3x70 + 54.6mm ²	34	1015
U096-3x70+70	INSULATED LOW VOLTAGE CABLE 3x70 + 70mm ²	36	1118

Others dimensions are available, [consult us](#).

Service



U313

MIRELEC

Application

This cable is used for the low voltage electricity overhead distribution. The conductor core is aluminum of wired type, covered with XLPE insulation.

Description

- The cable is delivered on wooden drums.
- The cable is available in single-phase 2x16mm² and 2 x 25mm² or three-phase 4x16mm² and 4x25mm² bundles.
- Each conductor is composed of 7 strands.

This cable meets the criteria of the **NF C 33-209** standard.

Nominal section (mm ²)	Nominal insulation thickness (mm)	External diameter of the maximal conductor (mm)	Approximate weight (kg/Km)	Maximum resistance at 20 °C (Ω/km)
2 x 16	1.20	5.1	130	1.91
4 x 16	1.20	5.1	280	1.91
2 x 25	1.40	9.4	205	1.20
4 x 25	1.40	9.4	512	1.20

Code	Designation	Sales unit
U305	METER OF TWISTED CABLE 2x16mm ²	The minimum sales unit is 1000m and then in 100m steps.
U306	METER OF TWISTED CABLE 4x16mm ²	
U312	METER OF TWISTED CABLE 2x25mm ²	
U313	METER OF TWISTED CABLE 4x25mm ²	

Aerial accessories



Connectors

MIRELEC

Application

These connectors are used to connect twisted aerial insulated conductors. Four items are available:



L227

Street light connector for powering street light lamp and performing tap connection of small section cables from a network (capacities: 16-95 / 1.5-10mm²)



K232

Service connector used to make a tap connection from the network to the customer (capacities: 16-95 / 2.5-35mm²)



U533

+ Bare conductors version is available (**L259**)

Service connector used to make a tap connection from a network to customer (capacities : 35-150 / 6-35mm²)



L256

Network connector used to make a tap connection from the network to the customer (capacities: 16-95 / 16-95mm²)



L356

Network connector used to make a tap connection between aerial networks (capacities: 35-150 / 35-150mm²)

Code	Designation	Capacities main (mm ²)	Capacities tap (mm ²)	Weight (kg)	Sales unit
FOR INSULATED CONDUCTORS					
L227	CONNECTOR CES / CT 95	16-95	1.5-10	0.060	200
K232	CONNECTOR CBS / CT 95	16-95	2.5-35	0.130	20
U533	CONNECTOR CBS / CT 35-150 / 6-35 A	35-150	6-35	0.100	100
L256	CONNECTOR CDRS / CT 95	16-95	16-95	0.140	50
L356	CONNECTOR CDRS / CT 150	35-150	35-150	0.400	30
FOR BARE CONDUCTORS					
L259	CONNECTOR RDP / CNA abc 6-35 / AI 7-95	7-95	6-35	0.130	20

 **Installation video** available on the website www.michaud-export.fr (Documentation tab> Implementation videos)

Fixing



U502



U501 + U502



U503

The anchoring assembly is used for single or double dead-ending of A.B.C (aerial bundled conductors) with insulated neutral messenger. Two different sections of neutral messenger are available: 54.6mm² and 70mm².

The suspension assembly is used for up-holding A.B.C (aerial bundled conductors) with insulated neutral messenger. Two different sections of neutral messenger are available: 54.6mm² and 70mm².

Code	Designation	Weight (kg)	Sales unit
U501	ANCHORING CLAMP 54.6mm ² - PA 54.6	0.410	30
U501-70	ANCHORING CLAMP 70mm ² - PA 70	0.530	25
U502	ANCHORING BRACKET 54.6mm ² - CA 54.6	0.235	50
U502-70	ANCHORING BRACKET 70mm ² - CA 70	0.300	60
U503	SUSPENSION ASSEMBLY 54.6mm ² - ES 54.6	0.510	30
U503-70	SUSPENSION ASSEMBLY 70mm ² - ES 70	0.650	25



U500_4X25

This accessory is used for anchoring service cable 2x6 up to 4x25mm².



F027

Code	Designation	Weight (kg)	Sales unit
U500_4X25	SERVICE ANCHORING CLAMP - PA 25	0.105	100
F027	ANGULAR CLAMP RA25	0.080	100

Nota: For pole hardware (BQC) supply, **please enquire**.

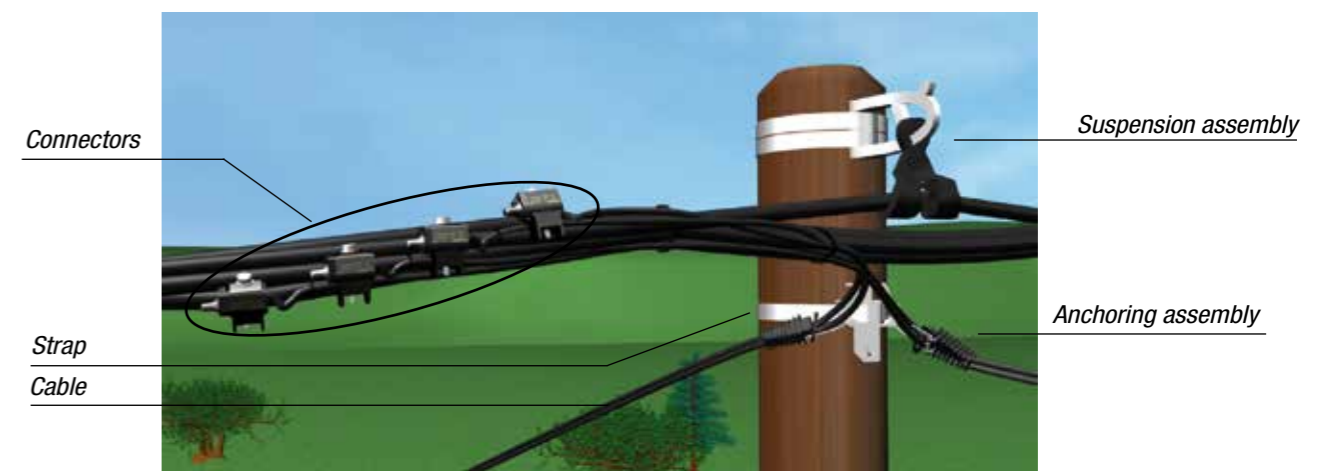

 **SEE SHEET**
Aerial service cable / Accessories / Stainless steel strap

Aerial accessories

Network junction



U507

Description

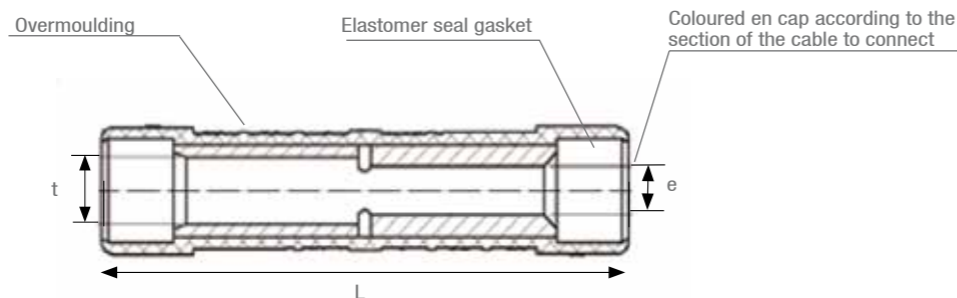

This preinsulated sleeve meets the requirements of the **NF C 33-021** and **EN 50-483** standards.

MIRELEC

Application

This preinsulated sleeve is designed for the junction of low voltage overhead insulated conductors to other ones. The junction can be established between two conductors of equal or unequal sections. All combinations of sections are possible.

Service junction



U509

Description

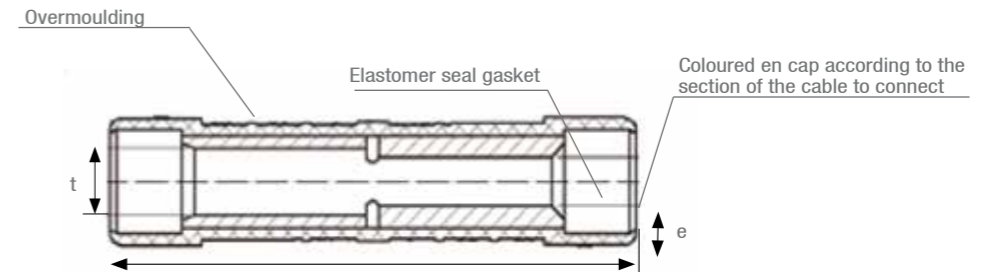

This preinsulated lug meets the requirements of the **NF C 33-021** and **EN 50-483** standards.

Code	Designation	Leading-in cable (mm ²)	Leading-in colour	Leading-out cable (mm ²)	Leading-out colour	Dimensions (mm)			Weight (kg)	Sales unit
						t	e	L		
PHASE SLEEVE REQUIRING A E173 CRIMPING DIE										
U507_16-16	MJPT SLEEVE 16-16	16	Blue	16	Blue	5.3	5.3	98.5	0.060	10
U507_25-25	MJPT SLEEVE 25-25	25	Orange	25	Orange	6.5	6.5		0.060	10
U507_35-25	MJPT SLEEVE 35-25	35	Red	25	Orange	7.9	6.5		0.050	10
U507_35-35	MJPT SLEEVE 35-35	35	Red	35	Red	7.9	7.9		0.060	10
U507_50-25	MJPT SLEEVE 50-25	50	Yellow	25	Orange	8.8	6.5		0.060	10
U507_50-35	MJPT SLEEVE 50-35	50	Yellow	35	Red	8.8	7.9		0.060	10
U507_50-50	MJPT SLEEVE 50-50	50	Yellow	50	Yellow	8.8	8.8		0.055	10
U507_54-25	MJPT SLEEVE 54-25	54.6	Black	25	Orange	10.2	6.5		0.050	10
U507_70-25	MJPT SLEEVE 70-25	70	White	25	Orange	10.4	6.5		0.050	10
U507_70-35	MJPT SLEEVE 70-35	70	White	35	Red	10.4	7.9		0.050	10
U507_70-50	MJPT SLEEVE 70-50	70	White	50	Yellow	10.4	8.8		0.050	10
U507_70-70	MJPT SLEEVE 70-70	70	White	70	White	10.4	10.4		0.050	10
U507_95-35	MJPT SLEEVE 95-35	95	Grey	35	Red	12.2	7.9		0.050	10
U507_95-50	MJPT SLEEVE 95-50	95	Grey	50	Yellow	12.2	8.8		0.050	10
U507_95-70	MJPT SLEEVE 95-70	95	Grey	70	White	12.2	10.4		0.050	10
U507_95-95	MJPT SLEEVE 95-95	95	Grey	95	Grey	12.2	12.2		0.050	10
NEUTRAL SLEEVE REQUIRING A E173 CRIMPING DIE										
U507_54N-54N	MJPTN SLEEVE 54-54	54.6	Black	54.6	Black	10.2	10.2	173.5	0.090	10
U507_54N-70N	MJPTN SLEEVE 54-70	54.6	Black	70	White	10.2	10.6		0.090	10
U507_70N-70N	MJPTN SLEEVE 70-70	70	White	70	White	10.2	10.6		0.080	10
NEUTRAL SLEEVE REQUIRING A E215 CRIMPING DIE										
U507_95N-95N	MJPTN SLEEVE 95-95	95	Grey	95	Grey	10.2	13.4	175.5	0.150	10

Code	Designation	Leading-in cable (mm ²)	Leading-in colour	Leading-out cable (mm ²)	Leading-out colour	Dimensions (mm)			Weight (kg)	Sales unit
						t	e	L		
U509_4-4	MJPB SLEEVE 4-4	4	Ivory	4	Ivory	2.9	2.9	74	0.050	150
U509_4-6	MJPB SLEEVE 4-6	4	Ivory	6	Brown	3.3	2.9		0.050	150
U509_4-10	MJPB SLEEVE 4-10	4	Ivory	10	Green	4.3	2.9		0.050	150
U509_4-16	MJPB SLEEVE 4-16	4	Ivory	16	Blue	5.3	2.9		0.050	150
U509_4-25	MJPB SLEEVE 4-25	4	Ivory	25	Orange	6.5	2.9		0.050	150
U509_6-6	MJPB SLEEVE 6-6	6	Brown	6	Brown	3.3	3.3		0.050	150
U509_6-10	MJPB SLEEVE 6-10	6	Brown	10	Green	4.3	3.3		0.050	150
U509_6-16	MJPB SLEEVE 6-16	6	Brown	16	Blue	5.3	3.3		0.050	150
U509_6-25	MJPB SLEEVE 6-25	6	Brown	25	Orange	6.5	3.3		0.050	150
U509_6-35	MJPB SLEEVE 6-35	6	Brown	35	Red	7.9	3.3		0.050	150
U509_10-10	MJPB SLEEVE 10-10	10	Green	10	Green	4.3	4.3		0.050	150
U509_10-16	MJPB SLEEVE 10-16	10	Green	16	Blue	5.3	4.3		0.050	150
U509_10-25	MJPB SLEEVE 10-25	10	Green	25	Orange	6.5	4.3		0.050	150
U509_10-35	MJPB SLEEVE 10-35	10	Green	35	Red	7.9	4.3		0.050	150
U509_16-16	MJPB SLEEVE 16-16	16	Blue	16	Blue	5.3	5.3		0.050	150
U509_16-25	MJPB SLEEVE 16-25	16	Blue	25	Orange	6.5	5.3		0.050	150
U509_16-35	MJPB SLEEVE 16-35	16	Blue	35	Red	7.9	5.3	0.050	150	
U509_16-50	MJPB SLEEVE 16-50	16	Blue	50	Yellow	8.8	5.3	0.050	150	
U509_25-25	MJPB SLEEVE 25-25	25	Orange	25	Orange	6.5	6.5	0.050	150	
U509_25-35	MJPB SLEEVE 25-35	25	Orange	35	Red	7.9	6.5	0.050	150	
U509_25-50	MJPB SLEEVE 25-50	25	Orange	50	Yellow	8.8	6.5	0.050	150	
U509_35-35	MJPB SLEEVE 35-35	35	Red	35	Red	7.9	7.9	0.050	150	
U509_35-50	MJPB SLEEVE 35-50	35	Red	50	Yellow	8.8	7.9	0.050	150	

SEE SHEET
ACCESS TO ENERGY / Distribution / Aerial accessories / Tooling

Aerial accessories

Ending fitting



U506

MIRELEC

Application

This spin-welded preinsulated lug is designed to connect low voltage overhead insulated conductors to copper equipment terminals. The cable sections range that the lug can receive goes from 16 to 150mm².

Description

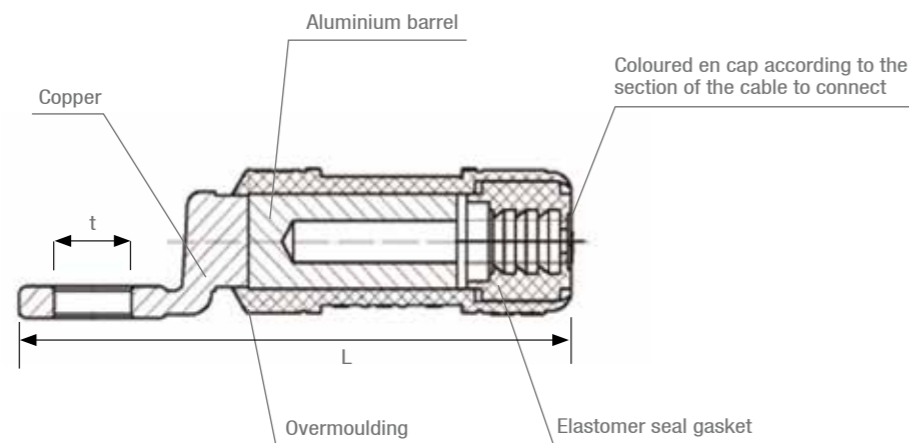

This preinsulated lug meets the requirements of the **NF C 33-021** and **EN 50-483** standards.

Code	Designation	Insulated Al-Cu cable (mm ²)	Dimensions (mm)		Weight (kg)	Sales unit
			t	L		
SPIN-WELDED PREINSULATED LUG REQUIRING A E140 CRIMPING DIE						
U506_16-10	CPTAU SPIN-WELDED LUG 16mm ² - DIAM 10	16	10.3	75	0.040	10
SPIN-WELDED PREINSULATED LUG REQUIRING A E173 CRIMPING DIE						
U506_25-10	CPTAU SPIN-WELDED LUG 25mm ² - DIAM 10	25	10.3	100	0.040	10
U506_35-13	CPTAU SPIN-WELDED LUG 35mm ² - DIAM 13	35	13	100	0.070	10
U506_50-13	CPTAU SPIN-WELDED LUG 50mm ² - DIAM 13	50	13	100	0.070	10
U506_54-13	CPTAU SPIN-WELDED LUG 54.6mm ² - DIAM 13	54.6	13	100	0.070	10
U506_70-13	CPTAU SPIN-WELDED LUG 70mm ² - DIAM 13	70	13	100	0.070	10
U506_95-13	CPTAU SPIN-WELDED LUG 95mm ² - DIAM 13	95	13	100	0.070	10
SPIN-WELDED PREINSULATED LUG REQUIRING A E215 CRIMPING DIE						
U506_120-13	CPTAU SPIN-WELDED LUG 120mm ² - DIAM 13	120	13	118	0.220	10
U506_150-13	CPTAU SPIN-WELDED LUG 150mm ² - DIAM 13	150	13	118	0.220	10

Tooling



F460



F445



K007



K005



U813-2



F400



F420 - F421 - F422

Application

These tools are used for the installation of pre-insulated connectors, sleeves and lugs.

Code	Designation	Weight (kg)	Sales unit
TOOLING FOR CONNECTORS INSTALLATION			
F445	INSULATED RATCHET WRENCH HEXAGONAL 13/17mm	0.380	1
F460	INSULATED CROSS SPANNER 8-10-13-17mm	0.400	1
K005	INSULATED WEDGE SEPARATOR	0.360	5
K007	INSULATED WEDGE SEPARATOR 200x15x9mm	0.050	100
TOOLING FOR SPIN-WELDED AND SLEEVE			
F400	50kN HYDRAULIC CRIMPING TOOL	2.350	1
F420	HEXAGONAL DIE TYPE E140	0.115	1
F421	HEXAGONAL DIE TYPE E173	0.115	1
F422	HEXAGONAL DIE TYPE E215	0.115	1
MEASURING DEVICE			
U813-2	CLAMP AMMETER	0.520	1

Stainless steel strap



MICHAUD

Application

This stainless steel strap is mainly used to fix the suspension or anchoring clamp brackets on all types of poles (wooden, metal or concrete).

Description

- This strap packaged in a 50m winder is available in four dimensions:
 - 10 x 0.4mm
 - 10 x 0.7mm
 - 20 x 0.4mm
 - 20 x 0.7mm
- The strap is made of stainless steel AISI 430. The strap edges are deburred.
- The strap delivered in a 50m roll inside a strengthened cardboard winder.

Code	Designation	Weight (kg)	Sales unit
K940	50m CARDBOARD WINDER STAINLESS STEEL STRAP EC 10x0.4mm	1.800	5
K941	50m CARDBOARD WINDER STAINLESS STEEL STRAP EC 10x0.7mm	2.800	5
K942	50m CARDBOARD WINDER STAINLESS STEEL STRAP EC 20x0.4mm	3.250	5
K943	50m CARDBOARD WINDER STAINLESS STEEL STRAP EC 20x0.7mm	5.690	5

Option:

Synthetic materials winder is also available.

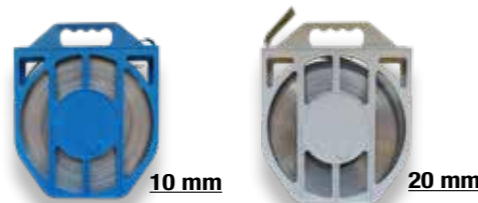

+ Other lengths and dimensions are available for stainless steel strap

Code	Designation	Weight (kg)	Sales unit
K945	50m WINDER STAINLESS STEEL STRAP EC 10x0.4mm	1.850	5
K946	50m WINDER STAINLESS STEEL STRAP EC 10x0.7mm	2.950	5
K947	50m WINDER STAINLESS STEEL STRAP EC 20x0.4mm	3.450	5
K948	50m WINDER STAINLESS STEEL STRAP EC 20x0.7mm	5.800	5

Tools



Description

The carrying case with ergonomic inside trim is made of synthetic material. It includes a cutting tool, binding tool ratchet type and buckles (to be ordered separately).

Implementation

- Cut the required length of strap using the cutting tool.
- Fix the strap around the pole and bracket using a binding tool and attach a buckle.
- Keep the cutting tool and binding tool in the suitable carrying case.

Code	Designation	Weight (kg)	Sales unit
L950	SET OF 100 BUCKLES EC FOR 10mm STRAP	0.320	1
L951	SET OF 100 BUCKLES EC FOR 20mm STRAP	0.610	1
K960	BINDING TOOL RATCHET TYPE FOR STRAP	1.950	1
K961	CUTTING TOOL FOR STRAP	0.550	1
K963	CARRYING CASE FOR STRAP TOOLS	0.550	1

Anti-climbing buckles



MICHAUD

Application

These stainless steel buckles are fixed onto the strap to prevent climbing on the pole and the fraud attempt.

Code	Designation	Weight (kg)	Sales unit
K956	SET OF 25 ANTI-CLIMBING STAINLESS STEEL BUCKLES	0.570	1



Video implementation available on the website www.michaud-export.fr (Documentation tab> Implementation videos)

Source, network and safety protection



Issues ?



Harsh climates of many developing countries create regularly disruptions on the lines. In order to protect people, the electrical production sources and networks, Michaud offers some **economical and enduring alternatives** to traditionnal solutions.



Mostly used in Europe, the thermal image circuit-breaker, installed at the top of the pole, causes inopportune power cuts in case of phases imbalance on the network. To avoid this inconvenience, Michaud has designed a very **economical fuse switch disconnecter equipped with fuses of high breaking capacity (HBC)**. This system has the advantage to add protection and breaking points, making easier the network operating and maintenance.



Michaud also proposes **earth system solutions** for people and installations protection.

Benefits ?

- + Safe and sustainable installations
- + Medium and long term profitability
- + Easier networks operating and maintenance



LV network fuse protection Gang fuse switch disconnecter



MICHAUD

Application

This multi-pole fuse switch disconnecter device is installed below a transformer at the top of the pole. It provides protection up to 160A or cut-off up to 240A. It is attached to the pole and thus protects the transformer and the low-voltage network below it. It protects single phase and three phase transformers.

Description

- The switch disconnecter is installed downstream:
 - Of the transformer 50kVA with fuses 80A,
 - Of the transformer 100kVA with fuses 160A,
 - Of the transformer 160kVA with neutral blade contacts, in order to create a breaking point on the network, each network outlet being possibly and independently protected with a disconnecter.
- This protection system is designed to secure the opening with cable energised and loaded.
- The terminals authorise a connection up to 95mm². The connection is performed with insulation piercing technology, insuring a reliable and secured contact.

The benefits :

- + 50 to 80% more economical than a circuit breaker
- + Strong solution, very little sensitive to charge imbalances
- + Solution available in **single phase and in three phases**

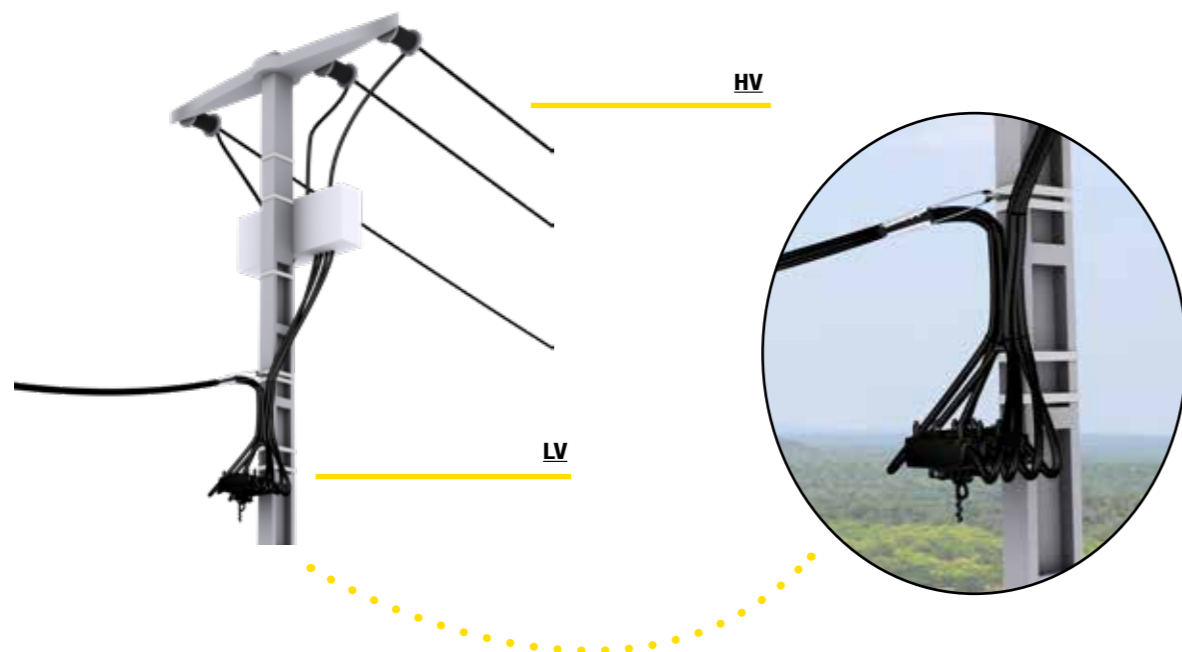

Option : Double Departure

A double start can be achieved thanks to the two insulating perforation derivatives with a capacity of 6-35mm².

Code	Designation	Weight (kg)	Sales unit
K298	DOUBLE POLE FUSE SWITCH DISCONNECTOR 160A (Size 00)	1.850	1
K293	TRIPLE POLE FUSE SWITCH DISCONNECTOR 160A (Size 00)	2.710	1
K294	QUADRUPLE POLE FUSE SWITCH DISCONNECTOR 160A (Size 00)	3.240	1
K098	DOUBLE TAP END CONNECTOR (6-35 mm ²)	1.850	1
K098	DOUBLE TAP END CONNECTOR (6-35mm ²)	0.115	12

Fixing with 2 galvanized steel screws of 10mm diameter is supplied with the disconnecter console.

SEE SHEET
ACCESS TO ENERGY / Protection / Fuses

Operating stick



Utilisation

This stick when equipped with an end enables to manipulate the fuse carrier from the ground. Its length is 2.65 folded and 5m unfolded. Each model is equipped with a notched universal U-shaped terminal end.

Code	Designation	Weight (kg)	Sales unit
F203	STICK 2E - 5M (TERMINAL U)	3.000	1
F209	BORED TERMINAL END DISCONNECTOR / STICK	0.105	10



Installation video available on the website www.michaud-export.fr (Documentation tab> Implementation videos)

Fuses

Fuse cartridge gG

- Available in:
- 10.3x38
 - 14x51
 - 22x58



MIRELEC

Application

These gG fuses cartridges are designed to protect goods. They are implemented in a cutout sheltered from outside weather conditions.

Description

- It is type gG HPC (High Breaking Capacity).
- It is not equipped with light indicator .

This fuse meets the criteria of the **NF/EN/IEC 60269-1**, **NF HD/IEC 60269-2**, **NF C 60200-1** et **NF C 60200-2** standards.

Code	Designation	Available models	Weight (kg)	Sales unit
U66X	FUSE CARTRIDGE 10.3x38 gG	1A to 32A	0.007	10
U66X	FUSE CARTRIDGE 14x51 gG	1A to 50A	0.021	10
U64X	FUSE CARTRIDGE 22x58 gG	2A to 32A	0.021	10

Cylindrical fuse AD

- Available in :
- 10.3x38
 - 14x51
 - 22x58



Utilisation

These AD fuse cartridges are used together with the circuit-breaker installed on the individual service tap connection. They perform the cutoff for high short-circuit currents and thereby extend the service life of the associated circuit-breaker, which is not overloaded up to the limit.

Description

- Low power loss limits heating of the device holding the fuse and extends its service life.
- It is specified for a nominal voltage of 440V in alternating current with nominal frequency of 50Hz.
- The nominal breaking capacity is 20kA.

This fuse meets the criteria of the **HN 62-S-83**, **NF/EN/IEC 60269-1**, **NF HD/IEC 60269-2** et **NF C60200-2** standards.

Code	Designation	Available models	Weight (kg)	Sales unit
Size 10.3x38				
U61X	FUSE CARTRIDGE 10.3x38 AD	5A to 15A	0.009	10
U620	NEUTRAL TUBE 10.3x38		0.012	10
Size 14x51				
U61X	FUSE CARTRIDGE 14x51 AD	15A to 45A	0.021	10
U621	NEUTRAL TUBE 14x51		0.016	10
Size 22x58				
U61X	FUSE CARTRIDGE 22x58 AD	15A to 90A	0.056	10
U622	NEUTRAL TUBE 22x58		0.028	10

Fuse cartridge size 00 AD



MIRELEC

Utilisation

These AD fuse cartridges are used together with the circuit-breaker installed on the individual service tap connection. They perform the cutoff for high short-circuit currents and thereby extend the service life of the associated circuit-breaker, which is not overloaded up to the limit.

Description

- The size of this blade fuse cartridge is 00 according to the **IEC 60269-2-1** standard.
- The fixing brackets are made of insulating synthetic materials.
- The accessible metal parts (screws), with the exception of the blades, are potential free and also have the degree of protection IP2X according to the **NF EN 60529** standard.
- Low power loss limits heating of the device holding the fuse and extends its service life.
- It is specified for a nominal voltage of 440V in alternating current with nominal frequency of 50Hz.
- The nominal breaking capacity is 20kA.

This fuse meets the criteria of the **HN62-S-83** standard.

Code	Designation	Available models	Weight (kg)	Sales unit
P24X	FUSE CARTRIDGE SIZE 00 AD	30A to 90A	0.150	10
P240	NEUTRAL BLADE CONTACT SIZE 00		0.060	10

Fuse cartridge NH1 and NH2

- Available in :
- 115 mm
 - 160 mm



Application

These low voltage fuses cartridges NH1 or NH2 are type gG. They are used as protection unit of the low voltage public electricity supply networks and works. It is installed in:

- Low voltage switchboards of the public electricity supply substations,
- Cutout boxes, inside or outside supply switches,
- Switch cabinets for subsurface networks,
- Metering boxes and cabinets for different uses.

Description

- The size of this blade fuse cartridge is NH1 or NH2 according to the **IEC 269-2-1** standard.
- It is specified for a nominal voltage of 440V in alternating current with nominal frequency of 50Hz.
- The nominal breaking capacity is 50kA minimum.

Code	Designation	Available models	Weight (kg)	Sales unit
U25X	FUSE CARTRIDGE NH1 115mm	63A to 250A	0.400	3
P238	NEUTRAL BLADE CONTACT NH2 115mm		0.210	1
P13X	FUSE CARTRIDGE NH2 160MM	125A to 400A	0.780	3
P239	NEUTRAL BLADE CONTACT NH2 160mm		0.290	1

Earth system



U2XX ou F2XX

Copper plated steel rod

MIRELEC

Application

These earth rods are used for earth system power networks. The copper coating made by an electrolytic process gives a resistance to corrosion as well as a good conductivity. The reference Standard is **EN 50 164-2**.

Code	Designation	Nominal diameter (mm)	Real diameter (mm)	Length (m)	Weight (kg)	Sales unit
50µm COPPER COATING						
U203	EARTH ROD COPPER 50µm L = 1m DIAM 12.7	14	12.7	1	1.025	10
U204	EARTH ROD COPPER 50µm L = 1.5m DIAM 12.7	14	12.7	1.5	1.537	10
U205	EARTH ROD COPPER 50µm L = 2m DIAM 12.7	14	12.7	2	2.050	10
F226	EARTH ROD COPPER 50µm L = 1m DIAM 14	16	14	1	1.250	10
F244	EARTH ROD COPPER 50µm L = 1.5m DIAM 14	16	14	1.5	1.900	10
F245	EARTH ROD COPPER 50µm L = 2m DIAM 14	16	14	2	2.500	10



Other earth rod dimensions are available (from 1m to 3m) as well as other treatments and thicknesses

Please enquire.

Option:



Earth rod ends threading available for a potential extension with screwed sleeves.

Please enquire.

Clamps



F234

Application

This clamp enables to establish a connection between the earth rod and the conductor.

Code	Designation	Nominal rod diameter (mm)	Maximal conductors section (mm²)	Screw	Weight (kg)	Sales unit
F234	CONNECTION CLAMP ROD DIAM 12.7 + 14 UNTHREADED	14 - 16	35	M8	0.050	50

Bare copper cable



U05X



The copper cable is available:
- in other dimensions
- in insulated copper cable

Please enquire

Code	Designation	Section (mm²)	Number of strands	Strand diameter (mm)	Weight (kg/km)
U051	BARE COPPER CABLE 16mm²	16	7	1.67	138
U052	BARE COPPER CABLE 25mm²	25	7	2.09	216
U053	BARE COPPER CABLE 29mm²	29	19	1.40	250
U054	BARE COPPER CABLE 35mm²	35	7	2.48	304
U055	BARE COPPER CABLE 50mm²	50	19	1.76	415

Connectors



U00X



U02X

Application

These connectors establish a mechanical and electrical connection between two conductors to guarantee the equipotentiality of the system, to make a tap connection or to fix a severed conductor.

Code	Designation	Main conductor (mm²)	Secondary conductor (mm²)	Weight (kg)	Sales unit
U003	"C" SHAPE CONNECTOR 25-6	10 - 25	4 - 6	0.012	10
U004	"C" SHAPE CONNECTOR 25-10	16 - 25	4 - 10	0.012	10
U005	"C" SHAPE CONNECTOR 25-25	16 - 25	16 - 25	0.017	10
U020	JUMPER CLAMP 6-16mm²	6 - 16	6 - 16	0.028	100
U021	JUMPER CLAMP 16-50mm²	16 - 50	16 - 50	0.061	50



U031



U034



U035



U036

Application

This earth system disconnection kit as well as these cutting blades allow the opening of the earth circuit in order to perform an earth resistance measure.

Code	Designation	Conductor section min (mm²)	Conductor section max (mm²)	Weight (kg)	Sales unit
U030	TUBULAR LUG 25-29	25	29	0.020	10
U031	EARTH SYSTEM DISCONNECTION KIT 25-29	25	29	0.060	20
U034	"T" SHAPE GROUND CUTTING BLADE	10	35	0.180	10
U035	HIGH GROUND CUTTING BLADE	16	35	0.310	3
U036	LOW GROUND CUTTING BLADE	16	35	0.150	3

Commercial reference index

	Code	Designation	Page	
F	F027	ANGULAR CLAMP RA25	56-57	
	F203	STICK 2E - 5M (TERMINAL U)	66-67	
	F209	BORED TERMINAL END DISCONNECTOR / STICK	66-67	
	F226	EARTH ROD COPPER 50µm L = 1m DIAM 14	70-71	
	F234	CONNECTION CLAMP ROD DIAM 12.7 + 14 UNTHREADED	70-71	
	F244	EARTH ROD COPPER 50µm L = 1.5m DIAM 14	70-71	
	F245	EARTH ROD COPPER 50µm L = 2m DIAM 14	70-71	
	F305	MULTIPLE ANCHORING BRACKET - CAM 25	18-19	
	F400	50kN HYDRAULIC CRIMPING TOOL	60-61	
	F420	HEXAGONAL DIE TYPE E140	60-61	
	F421	HEXAGONAL DIE TYPE E173	60-61	
	F422	HEXAGONAL DIE TYPE E215	60-61	
	F445	INSULATED RATCHET WRENCH HEXAGONAL 13/17mm	60-61	
	F460	INSULATED CROSS SPANNER 8-10-13-17mm	60-61	
	F493	STRIPPING TOOL 6mm ²	52-53	
	K	K005	INSULATED WEDGE SEPARATOR	60-61
		K007	INSULATED WEDGE SEPARATOR 200x15x9mm	60-61
K098		DOUBLE TAP END CONNECTOR (6-35mm ²)	66-67	
K221		CUTOUT SLEEVE 63A (22x58) PIERCING 6-35	18-19	
K223		FUSE CONNECTOR PIERCING 95/16	42-43	
K232		CONNECTOR CBS / CT 95	42-43 56-57	
K248		FRAUD-PREVENTING CABLE FULFILMENT KIT - 13mm ² SINGLE PHASE	16-17	
K249		FRAUD-PREVENTING CABLE FULFILMENT KIT - 20mm ² THREE PHASE	16-17	
K265		BELT SUSPENSION WITH RING	52-53	
K293		TRIPLE POLE FUSE SWITCH DISCONNECTOR 160A (Size 00)	66-67	
K294		QUADRUPLE POLE FUSE SWITCH DISCONNECTOR 160A (Size 00)	66-67	
K298		DOUBLE POLE FUSE SWITCH DISCONNECTOR 160A (Size 00)	66-67	
K310		ANCHORING CLAMP CONCENTRIC CABLE SINGLE PHASE	18-19	
K311		CONCENTRIC STRIPPING PLIERS	16-17	
K480		ELECTRONIC LIMITER CABINET 50-75	44-45	
K481		ELECTRONIC LIMITER CABINET 75-250	44-45	
K482		ELECTRONIC LIMITER CABINET 250-1000	44-45	
K488		PROGRAMMABLE ENERGY MANAGER BLUETOOTH DONGLE + TABLET	42-43	
K497		PROGRAMMABLE ENERGY MANAGER CABINET 20 - 1 500W	40-41	
K498		PROGRAMMABLE ENERGY MANAGER MODULE 20 - 1 500W	40-41	
K499		PC ENERGY MANAGER KIT	42-43	
K811		CUSTOMER BOARD 25-75VA	44-45	
K812		CUSTOMER BOARD 75-250VA	44-45	
K813		CUSTOMER BOARD 250-1000VA	44-45	

K	K84X	METER CABINET 1.0	46-47	
	K85X	METER CABINET 2.0	46-47	
	K94X	50M CARDBOARD WINDER STAINLESS STEEL STRAP EC	62-63	
	K945	50M WINDER STAINLESS STEEL STRAP EC 10x0.4mm	62-63	
	K94X	50M WINDER STAINLESS STEEL STRAP EC 10x0.7mm	62-63	
	K956	SET OF 25 ANTI-CLIMBING STAINLESS STEEL BUCKLES	62-63	
	K960	BINDING TOOL RATCHET TYPE FOR STRAP	62-63	
K961	CUTTING TOOL FOR STRAP	62-63		
K963	CARRYING CASE FOR STRAP TOOLS	62-63		
L	L227	CONNECTOR CES/CT 95	52-53 56-57	
	L256	CONNECTOR CDRS / CT 95	56-57	
	L259	CONNECTOR RDP / CNA ABC 6-35 / AI 7-95	56-57	
	L304	FIXING CLAMP - PF25	18-19	
	L304	FIXING CLAMP - PF25	52-53	
	L306	SCREW M10	52-53	
	L356	CONNECTOR CDRS / CT 150	56-57	
	L950	SET OF 100 BUCKLES EC FOR 10mm STRAP	62-63	
	L951	SET OF 100 BUCKLES EC FOR 20mm STRAP	62-63	
	P	P126	MINI SWITCH 10A 22x58	26-27
P135		MINI SWITCH 5A 14x51	26-27	
P136		MINI SWITCH 5A 22x58	26-27	
P137		MINI SWITCH 5A T00	26-27	
P13X		FUSE CARTRIDGE NH2 160mm	68-69	
P142		MINI SWITCH 15A 14x51	26-27	
P143		MINI SWITCH 15A 22x58	26-27	
P144		MINI SWITCH 15A T00	26-27	
P146		MINI SWITCH 20A 22x58	26-27	
P238		NEUTRAL BLADE CONTACT NH2 115mm	68-69	
P239		NEUTRAL BLADE CONTACT NH2 160mm	68-69	
P240		NEUTRAL BLADE CONTACT SIZE 00	68-69	
P24X		FUSE CARTRIDGE SIZE 00 AD	68-69	
P429		SERVICE DISTRIBUTION BOX 8 OUTLETS	20-21	
P431		INSULATION PIERCING AERIAL CONNECTION BOX 3 OUTLETS	28-29	
P432		STRIPPING AERIAL CONNECTION BOX 3 OUTLETS	28-29	
U		U003	C SHAPE CONNECTOR 25-6	70-71
		U004	C SHAPE CONNECTOR 25-10	70-71
		U005	C SHAPE CONNECTOR 25-25	70-71
	U020	JUMPER CLAMP 6-16mm ²	70-71	
	U021	JUMPER CLAMP 10-50mm ²	70-71	
	U030	TUBULAR LUG 25-29	70-71	
	U031	EARTH SYSTEM DISCONNECTION KIT 25-29	70-71	
	U034	T SHAPE GROUND CUTTING BLADE	70-71	
	U035	HIGH GROUND CUTTING BLADE	70-71	
	U036	LOW GROUND CUTTING BLADE	70-71	
	U05X	BARE COPPER CABLE	70-71	
	U096	ISOLATED CABLE LOW VOLTAGE	54-55	
	U203	EARTH ROD COPPER 50µm L = 1M DIAM 12.7	70-71	

Commercial reference index

Notes

U

U204	EARTH ROD COPPER 50µm L = 1.5M DIAM 12.7	70-71
U205	EARTH ROD COPPER 50µm L = 2M DIAM 12.7	70-71
U25X	FUSE CARTRIDGE NH1 115mm	68-69
U300	AERIAL SERVICE CABLE 2x6mm ²	52-53
U301	AERIAL SERVICE CONCENTRIC CABLE 13mm ² SINGLE PHASE	16-17
U302	AERIAL SERVICE CONCENTRIC CABLE 20MM ² THREE PHASES	16-17
U304	AERIAL SERVICE CABLE 4x6mm ²	52-53
U305	METER OF TWISTED CABLE 2x16mm ²	54-55
U306	METER OF TWISTED CABLE 4x16mm ²	54-55
U307	AERIAL SERVICE CONCENTRIC CABLE 16mm ² SINGLE PHASE	16-17
U308	AERIAL SERVICE CONCENTRIC CABLE 25mm ² THREE PHASES	16-17
U312	METER OF TWISTED CABLE 2x25mm ²	54-55
U313	METER OF TWISTED CABLE 4x25mm ²	54-55
U500	ANCHORING CLAMP 2x6mm ² - PA6	52-53
U500 4x6	ANCHORING CLAMP 4x6mm ² - PA4x6	52-53
U500_4X25	SERVICE ANCHORING CLAMP - PA 25	56-57
U501	ANCHORING CLAMP 54.6mm ² - PA 54.6	56-57
U501-70	ANCHORING CLAMP 70mm ² - PA 70	56-57
U502	ANCHORING BRACKET 54.6mm ² - CA 54.6	56-57
U502-70	ANCHORING BRACKET 70mm ² - CA 70	56-57
U503	SUSPENSION ASSEMBLY 54.6mm ² - ES 54.6	56-57
U503-70	SUSPENSION ASSEMBLY 70mm ² - ES 70	56-57
U506_XX-XX	CPTAU SPIN-WELDED LUG	60-61
U507_XX-XX	MJPT SLEEVE	58-59
U507_54N-54N	MJPTN SLEEVE 54-54	58-59
U507_54N-70N	MJPTN SLEEVE 54-70	58-59
U507_70N-70N	MJPTN SLEEVE 70-70	58-59
U507_95N-95N	MJPTN SLEEVE 95-95	58-59
U508	ANCHORING CLAMP CONCENTRIC CABLE THREE phasES	18-19
U509_XX-XX	MJPB SLEEVE	58-59
U533	CONNECTOR CBS / CT 35-150 / 6-35 A	56-57
U61X	FUSE CARTRIDGE 10.3×38 AD	68-69
U61X	FUSE CARTRIDGE 14×51 AD	68-69
U61X	FUSE CARTRIDGE 22×58 AD	68-69
U62X	NEUTRAL TUBE	68-69
U64X	FUSE CARTRIDGE 22×58 gG	68-69
U66X	FUSE CARTRIDGE 10.3×38 gG	68-69
U66X	FUSE CARTRIDGE 14×51 gG	68-69
U813-2	CLAMP AMMETER	60-61

Web site

Discover our latest news, catalogues, products range as well as information mediums to assist you in the use of our products.

www.michaud-export.com



LinkedIn

Join us on Michaud Export's LinkedIn network to follow the company's development and to share with us.

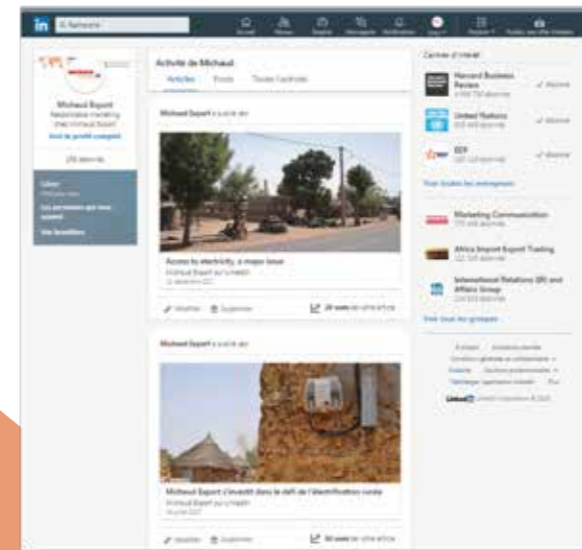

YouTube

Follow our YouTube channel in order to discover products implementation videos and this way facilitate your installations on the field.



Implementation

These products must be implemented and used in **compliance with the applicable regulations** with a skilled, qualified professional undertaking to do so following the generally accepted rules of the trade.

For **live-line** implementation or handling, the electrician must comply with the requirements for live-line work conditions and must be equipped with the necessary personal protection equipment. The implementation temperature limits are: -10°C to +40°C.

Live-line work is carried out under the responsibility of the ordering customer in compliance with the applicable rules.

Before powering up the equipment, all the required verifications must be carried out.

Tools

The product should be installed and used with **suitable tools**.

The screw heads should be driven in and tightened with the appropriate tool: **allen key** for hexagonal cap screws, **flat screwdriver** for slotted screw heads of the right size, **Phillips screwdriver** for cruciform screw heads, **HSHC screw head (awls)** for hollow hexagonal screw heads, etc. The screw heads with no torque-limiting device must be tightened to the recommended torque and must not be tightened again.



Recommendations for use

The installation instructions must be read carefully before using the product.

The product must be used and implemented in compliance with these recommendations for use and installation instructions; it must be used for the applications for which it was defined by the operator/manager of the network and on an electrical installation that is compliant and compatible with the product.

Never exceed the capacities indicated on the device and in the instructions sheet.

Unless explicitly indicated, products are designed for no-load connection.



Environment

Please group your waste together and follow the recycling and destruction instructions before leaving the worksite.

1. APPLICATION OF CONDITIONS:
Purchaser make himself acquainted with these general selling conditions which shall lay down the Parties law, except purchaser's written denunciation ratified by MICHAUD EXPORT and despite opposite clauses that could be included in the purchaser's general conditions. Possible renunciation of one or few clauses herein does not interfere with the validity of the other clauses.
Except any formal and express derogation made by MICHAUD EXPORT, all purchaser's orders carry off his full and entire consent to the present General Selling Conditions which prevail over any Purchasing Conditions. All particular purchasing clauses or conditions aiming to modify the present conditions must not be contrary to the seller's ones.
2. ORDER:
Any order shall not constitute a contract unless accepted in writing by MICHAUD EXPORT.
3. PRICE LIST:
3.1 Unless otherwise stated by MICHAUD EXPORT, price lists and commercial offers are established in Euro €, excluding any other currency, even Euro indexed currencies, and is governed by Incoterms 2010 to be defined with the purchaser in the particular conditions.
3.2 The price list is established for standard items with specific given technical characteristics. Any technical changes on products to adapt them to other specifications or standards may lead to extra unit costs and price revision.
3.3 Unless otherwise stated by MICHAUD EXPORT, MICHAUD EXPORT reserves the right to gather purchaser's orders and to deal with according to a minimum invoice amount of 800 € excluding tax and freight charges (according to general price list in due force on the order date). Any order which amount is lower than 1 500 € shall result in the invoicing of a fixed sum of 150 € meant to cover administrative fees.
3.4 Unless otherwise stated and written by MICHAUD EXPORT, validity of the price list is one month starting when given to the purchaser.
3.5 The price list is subject to alteration without notice.
4. DELIVERY TIME:
4.1 The delivery time is defined as the case may be according to the commercial relationships established with the purchaser. MICHAUD EXPORT use their best endeavours to deliver the goods by the time fixed for delivery, however, in case of delay, they will not be responsible for any loss or damage thereby caused to the purchaser unless expressly accepted in writing by MICHAUD EXPORT.
4.2 Should partial or delayed deliveries occur, it does not justify any cancellation of purchaser's orders, and MICHAUD EXPORT shall not be liable and responsible for any actual or potential, direct or indirect, or consequential damages caused to the purchaser through delay or by failing on deliveries.
5. DISPATCH:
5.1 MICHAUD EXPORT use their best endeavours to select appropriate method of delivery with no responsibility on it. Choice shall be made freely unless purchaser's contrary notice who then support following additional cost that may follow.
5.2 Ex-works delivery is considered as an effective delivery, notably regarding modalities and payment terms.
5.3 Partial loss or damage during in transit must be reported to the carrier and to MICHAUD EXPORT in writing by registered letter with proof of delivery within three days after receipt of the goods by the purchaser. If these conditions are not complied with, the purchaser will be responsible for any loss or damage that may occur during transit.
The purchaser commits to return to MICHAUD EXPORT at his own costs and risks the products he rejected during his check-up for due investigation. The purchaser agrees that MICHAUD EXPORT shall return the products at the purchaser's cost and risks after examination or any possible repair or replacement.
6. USE OF THE PRODUCTS:
The purchaser has to follow imperatively the laws, current prescriptions in due force and custom rules regarding instruction procedures and use of the products. MICHAUD EXPORT shall not be responsible in case of wrong use of the products according to the specifications and prescriptions of use advised by MICHAUD EXPORT.
7. TESTING AND INSPECTION:
When testing and/or inspection is required by the purchaser, tests shall be carried out at MICHAUD SA's facilities, and relevant costs shall be covered by the purchaser, unless any exemption agreed and approved by MICHAUD EXPORT.
8. WARRANTY:
8.1 MICHAUD EXPORT guarantees the purchaser against latent defect of the goods according to the conditions driven by the law.
Once a guaranteed shortcoming is stated by the buyer, it is up to him to send his reclamation to MICHAUD EXPORT with a registered letter with proof of delivery within a time limit of three months starting from the fault's appearance.
This reclamation has to be accompanied by a detailed description of the fault's nature.
After this period of time the goods delivered shall be deemed as in good condition and the purchaser is no longer entitled to make a complaint about any defect on the products.
8.2 MICHAUD EXPORT guarantees its products for a period of one year after delivery or shifting from our facilities.
In case of fault, defect, non-conformity proved or admitted by MICHAUD EXPORT, MICHAUD EXPORT undertakes to replace the products admitted defective in reasonable time. In order to be replaced, rejected products shall be returned. No other prejudice of damage shall be required by the purchaser.
8.3 The guarantee is excluding the followings:
- If the product has been repaired or modified by the buyer or by third parties chosen by him ; or
- If it concerns items that have been made by sub-contractors or MICHAUD EXPORT
9. TAKING BACK OF THE PRODUCTS:
In case the purchaser renounces to the ordered and delivered products, no taking back will be considered unless expressly accepted in writing by MICHAUD EXPORT. Rejected goods shall be sent back to the French plant defined by MICHAUD EXPORT. Credit of the sent back goods will be registered after receipt in the warehouse. Taking back value will systematically take into consideration a reduction to be defined for administrative and check-up cost as well as a reduction for restoration of the product and packaging if necessary.
10. PAYMENT:
10.1 Payment terms are defined with the purchaser in the particular conditions. All goods shall be paid to the MICHAUD EXPORT head office located in Viriat France whatever the payment terms used. Invoice date shall be the starting point of the settlement period.
10.2 Legal property transfer of the goods shall be retained until full payment of the whole sold goods. MICHAUD EXPORT keep the property of the goods until full payment of their price, sending bank drafts or any other bond notes building payment obligation not constituting a payment.
10.3 Any unpaid draft or invoice being at maturity will produce due interest, without giving notice. Applicable penalties shall be equivalent to three times the legal interest rate at the payment date located on the invoice. Payment of any other sums owed by the failing debtor shall be immediately payable, even if they are accepted draft. Any full or partial non-execution by the Customer of the payment obligations or any delay in payment shall, without prejudice to any damages and interests, lead to the payment of fees of 40 € for collection charges set down by decret made pursuant to the section 121 of this act. Moreover, MICHAUD EXPORT keep the right, in that case, to suspend or cancel fulfilment of the contracts and pending orders and demand cash in advance payment of any other delivery, whatsoever past conditions agreed for such delivery.
10.4 Any change in the purchaser situation regarding sale or other party's investment in the business, decease, incompetence, suspension of payment, official recovery, official receivership, temporary proceedings suspension, dissolution or form modification, even after partial fulfilment of the contracts or pending orders entails application of the same conditions as the ones described in case of unpaid invoice.
11. FORCE MAJEURE:
Neither MICHAUD EXPORT nor the buyer can be held responsible for a possible delay or lack in their obligations' execution, if this delay or lack is the result of a force majeure. A force majeure exists notably in the following situations, if they present certain characteristics of a force majeure, this means if the event was irresistible, unforeseeable, and externally provoked. This non-exhaustive list enumerates some situations which constitute a force majeure: explosions, fires, incidents, destruction of machinery, factories and equipment, natural disasters, acts by governmental authorities (refusing or cancellation of a license ...), wars, or any acts of war, flooding, riots, or social conflicts.

The party that faces such a circumstance which responds to the above given definition must immediately inform in writing the other party of this intervention and when this circumstance possibly ends. In the case of absence of information, the concerned party can not prevail over, unless in the case of intervening circumstances, which also prevent any communication.

Where a force majeure case which responds to the above definition intervenes, the time for the contract's execution is prolonged for a period of time corresponding to the event's duration. This does not include any payment of damages and interest or a penalty for the delay.
However if the above mentioned circumstances do persist for a period of time of 6 months, each party can cancel the contract without any payment of damages and interest.
12. CANCELLATION:
The contract is cancelled by law, without the need of any judicial formality where there are serious shortcomings by one of the parties concerning essential obligations. Cancellation would become effective within one month after the mailing of a registered letter with proof of delivery of an earlier made formal notice which stayed unfruitful.

The essential obligations, which the parties have to fulfill, notably consist of the due payment by the buyer or the merchandise's non-delivery by MICHAUD EXPORT. In case of a serious shortcoming to the contract's essential obligations, the sale will be cancelled in good law without prejudice of damages and interest that can be claimed.

Any tolerance that one party allows the other not to prevail immediately over one of its rights, will not prejudice the party's rights to prevail over them later, except in case of a contrary convention or stipulation to the present conditions.
13. JURISDICTION ATTRIBUTION:
These General Selling Conditions shall be ruled and governed by the French Law as followed by the courts. Any dispute deriving from these General Selling Conditions, after failure of a previous conciliation procedure shall be of the exclusive French jurisdiction of the competent Commercial Court of Lyon located in France. Each party accepts to bear any costs and expenses it would have exposed.
14. OFFICIAL LANGUAGE:
The French version of these general selling conditions, available upon enquiry, is the only legally acceptable version.



Creator of electrical equipment



Discover our Web Site
and make your own
customized catalogue!

International expert in electrical distribution, **Michaud Export** designs, develops and implements reliable systems reducing maintenance operations on distribution networks.

As the architect of your solution, the company focuses on on-going innovation and leverages on the worldwide renowned expertise of the 250 employees at **Michaud Group**, leader in the industry for systems and connection fittings for electrical installations.

Michaud Export

499, Rue du Revermont
ZAC La Cambuse
01440 Viriat
France
Tél +33 (0)9 70 75 50 24
contact@michaud-export.com
www.michaud-export.com

