



2020/2021

Electrical Distribution

Our energy at your service

Catalogue
Low Voltage Energy

MICHAUD
Export 



The French Group Michaud, has been designing, qualifying, producing and selling electrical equipment and connection systems for over 60 years.

According to the international standards, **Michaud Export** designs and develops energy distribution solutions. The product range is focused on two fields of expertise:

Michaud Export
in a few words:

Reliability
Support
Adaptability
Quality
Innovation
Expertise
Reactivity
Experience
Listening

- **Low Voltage Network:** to connect and protect the overhead and underground electrical lines ;

- **Energy Controlling:** to manage and offer easy access to electricity.



Creator of innovative solutions

Supplier of electrical equipment

As a **technical expert in low-voltage networks**, Michaud focuses R&D on innovative solutions.

From MV/LV transformer substation to the end customer, Michaud Export offers all **electrical equipment for the construction & maintenance** of overhead and underground lines.

Thanks to an **engineering Department dedicated to international business**, Michaud Export provides support to Power Utilities in their grid expansion projects.

In addition to low-voltage networks, Michaud Export also offers **solutions for residential electrical distribution and smart metering.**

From protection to connections, many **innovative solutions** are already used in major Power Utilities around the world.



250
staff members



7

establishments
Europe,
North Africa,
Asia



Certified since



8 to 10%
of turnover
invested in R&D



1

Accredited
Test Laboratory



3
Engineering departments

* Accréditation n° 1-0579 portée disponible sur www.cofrac.fr

From R&D to after-sales service, **Michaud Export**, as a Michaud subsidiary, has full mastery of its value chain, ensuring high-level quality and service worldwide.



MIRELEC

Mirelec is a Michaud brand, dedicated to low voltage electrical distribution equipment.

The brand offers **European quality** products and solutions at a **price matching emerging markets expectations.**



Protection p. 82



Housing p. 186



Overhead p. 8



MICHAUD
Export 

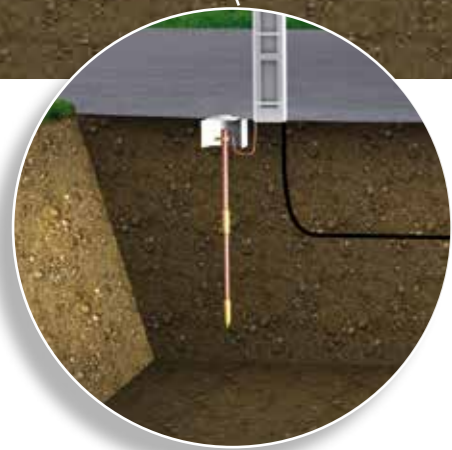

Earth system p. 116

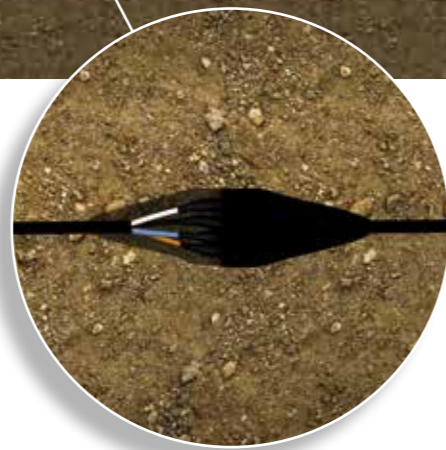

Underground p. 146



Installation p. 212



Contents

Overhead

p.8

LV service connector	p.14
LV network connector	p.28
LV street light connection	p.36
LV junction	p.40
LV ending fitting	p.52
LV mechanical fixing	p.60
MV accessories	p.80

Protection

p.82

Service protection	p.88
Network protection	p.102
Fuses	p.112

Earth system p.116

Earth electrodes	p.124
Earth connectors	p.132
Earth conductors	p.138

Underground p.146

Underground service	p.154
Underground network	p.166
Emerging connection	p.174
Accessories	p.182

Housing

p.186

Smart Meter Equipment	p.190
Universal flexible linking cable	p.202

Installation p.212

Personal protective equipment	p.216
Collective protective equipment	p.226
LV line unwinding and pulling	p.228
Overhead pulling grip and swivel	p.230
LV insulated toolings	p.232
Hydraulic crimping tool	p.238

Overhead

Overhead

LV service connector

Service insulation piercing connector	p.14
Service insulation piercing connector with Test Probe	p.16
Service insulation piercing connector for bare conductor	p.18
Two stage bare conductor service connector	p.20
Service connector with independent tightening	p.22
Multitap service connector	p.24
Multitap aerial connection box	p.26

LV network connector

Network insulation piercing connector	p.28
Network insulation piercing connector fo bare conductor	p.30
Network insulation piercing connector with dismountable tap contact	p.32
Parallel groove jaw	p.34

LV street light connector

Street light insulation piercing connector	p.36
Street light kit	p.38
Cold shrink end cap	p.39

LV junction

Service cable dismountable sleeve and mains connection box ..	p.40
Network preinsulated sleeve with mechanical tightening	p.42
Preinsulated sleeve E140	p.44
Preinsulated sleeve E173	p.46
Preinsulated sleeve E215	p.48
Preinsulated sleeve for aerial sub-surface connection E140	p.50

LV ending fitting

Preinsulated CPTAU lug	p.52
Bare lug	p.54
Sealing end cap and cover	p.56
Heat-shrinkable material	p.58

LV mechanical fixing

Stainless steel strap	p.60
Neutral messenger network suspension and anchoring	p.62
Fully supported network suspension and anchoring	p.64
Service cable anchoring	p.66
Low voltage line accessories	p.68
Cable saddle	p.70
Cable tie	p.72
Pigtail bolt	p.74
Hot dip galvanised bolt and nut	p.76
Protection accessories	p.78

MV accessories

IPC for MV BLL/BLX conductor	p.80
------------------------------------	------



The **low voltage overhead connectors** range is the historical core business of MICHAUD. The company has been able to integrate the issues of worldwide power utilities into the design of its products.



Expertise

MICHAUD developed its **technical skills** with the transition of overhead bare lines into Aerial Bundled Conductors (A.B.C). Thanks to large **innovation ability**, the company has been a pioneer for a long time in the adaptation to this new environment.



Durability

MICHAUD acquired a **solid experience in electrical connections** and more specifically in the fields of insulation piercing, bimetal connections and crimping guaranteeing the power lines durability.



Competitiveness

By taking into account the **overall cost** of the products over years (purchasing, maintenance, energy performance), MICHAUD offers a long terms **competitive range** of low voltage line accessories (with service life higher than 40 years).

Optimisation of the LV electrical line cost

Analysis of the line cost

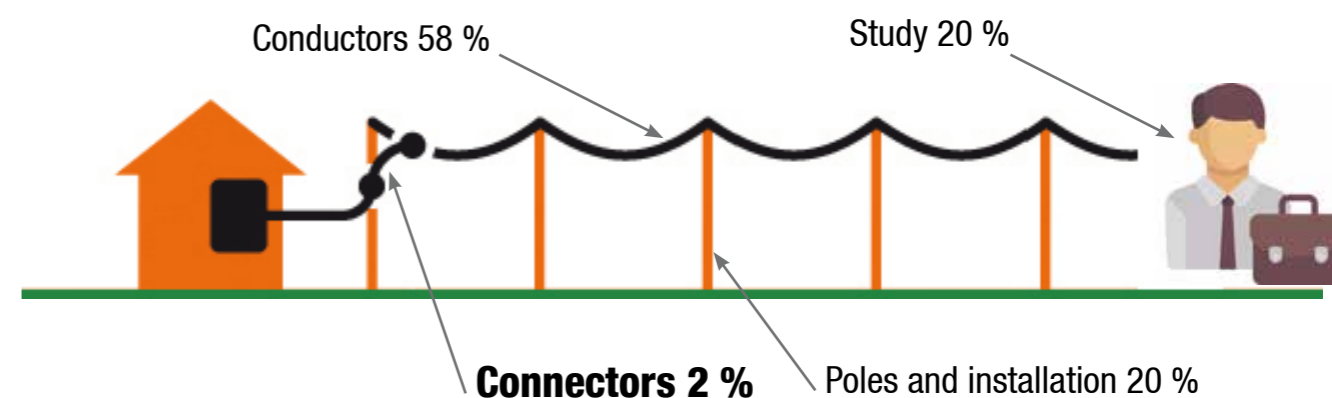

Cost allocated to connectors is only about **2 %**. However this item is at the origin of **80 %** of network incidents that can possibly damage the full line especially conductors of high value.

Solutions for qualitative connections

Incidents can result from:

- connector failure,
- installation mistake,
- insubstantial training.

An incorrect installation can lead to dangerous risks for people safety and electrical line efficiency.

MICHAUD solutions aim to facilitate the installation and therefore avoid fitters mistake thanks to technologies enabling to ensure a correct and effective installation: captive screws, overmoulding, shear head, user instructions delivered with the product...

Other options have been designed to make the installation, even easier.

Risks

Faulty installation

Burning caused by main tap conductors bad connection

Water penetration in the connection due to bad waterproofness

MICHAUD solutions

+ Possibility to check potential between two conductors

+ Possibility to check shear head break from ground level

+ Captive end cap because linked to connector

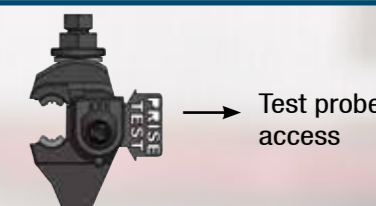

Test probe access



Yellow shear head break indicator



Fixed end cap



A proven technology for many years

To guarantee the connections waterproofness on Aerial Bundled Conductors is significant challenge. A connection that is not set-up the right way can lead to a risk of water penetration and endanger the security and durability of the equipment.

MICHAUD experience

In the 1980's, MICHAUD was first producer in the world to develop the preinsulated compression sleeve MJPB for the Power French Company ErDF. This sleeve designed to offer a dielectric strength of 6kV into water was really appreciated. This technology has been expanded today to other products of the range showing reliability and efficiency on the field.

For
35 years



MICHAUD preinsulated sleeves range

Compression sleeve



MJP
Preinsulated sleeve

Service sleeve with
mechanical tightening

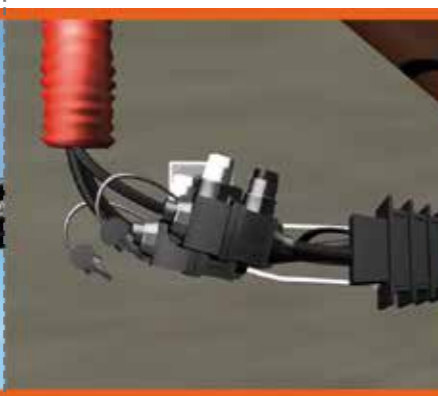

MDB
Dismountable service sleeve

Network sleeve with
mechanical tightening



MJS
Underground sleeve

Service (**MJPB**)
A.B.C. network (**MJPT**)
Service aerial sub-surface (**MJPBAS**)

A diversity and flexibility with the offer

An adaptation to projects and local requirements is possible thanks to MICHAUD human scale and its wide range enabling **reactivity** and **flexibility** when facing specific applications.

Options

- Bare or insulated **cable**
- ✓ From 1.5 up to 240mm²
- ✓ Compatible with RIB

- Synthetical or metallic **hexagonal shear head**
- ✓ Removable / unremovable
- ✓ Thrust washer
- ✓ Breaking torque controller (with coloured indicator)

Overmoulded or assembled **sealing**

- Glued or movable **sealing end cap**
- ✓ Test probe access
- ✓ Rigid (Class II)

- Simultaneous or independent tightening**
- 1,2 or 4 conductors

- Contact bridges** copper, brass, aluminium with a choice of surface treatments (tinning)
- ✓ Stripping
- ✓ Piercing

Engraved marking

OF 153911

Batch number: YYWWXX
Y: Year / W: Week / X: Number

- ✓ Systematic traceability
- ✓ Special series with own marking

- Steel **fastener** with different treatments (zinc, galvanised, ...) or stainless steel fastener
- ✓ Captive components

MICHAUD expertise

Development and certification of products in compliance with every worldwide standards:



IEC

EN

DIN

AISI

AS

NZ

Service insulation piercing connector



K322



K441
with yellow shear head indicator

MICHAUD

Application

This connector is designed to connect the insulated service conductors to the low voltage A.B.C. (Aerial Bundled Conductors).

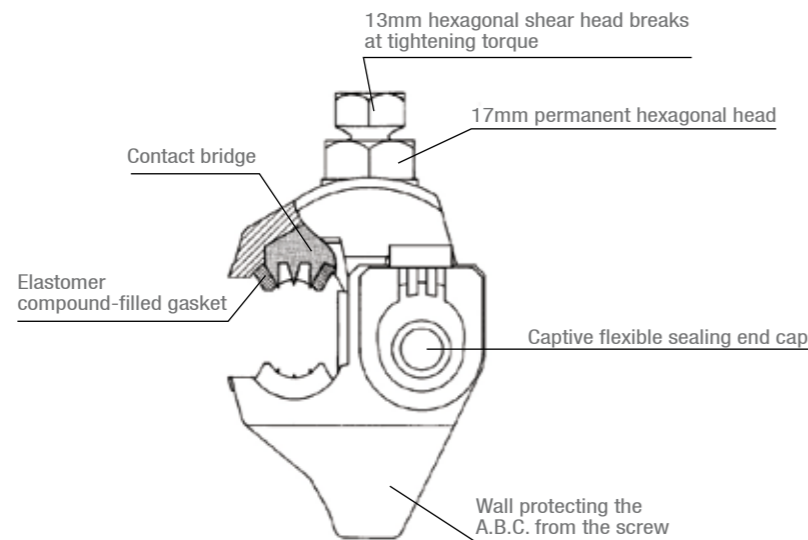

Description

Connector general features:

- Insulation piercing is carried out on the main and tap conductors simultaneously in a single tightening operation.
- The dielectric strength in water is greater than 6kV.
- The tightening screw is potential free.
- Tightening efficiency is ensured by a shear head screw.
- Connectors K441, K442 and K443 are fitted with a yellow shear head indicator that disappears when head is sheared-off, being a clear visual confirmation of good tightening from ground level. It increases head height by 10 mm.

This connector meets the criteria of the **NF C 33-020** and **EN 50-483** standards.

Connector end cap:

- The connector end cap is flexible so that to feel good tap conductor insertion simply by hand.
- It is carrying membranes instead of grease, granting watertightness around tap conductor end on long term basis.
- It is glued on connector body so that to avoid eventual loss during handling, installation and environment (wind, bad weather...).
- It can be equipped with a hard end cap, gripping and covering so, in case rigid cover is required. (Part Number K246 : please enquire for further information).



Installation video available on www.michaud-export.com
(tab Documentation > Installation videos)

Code	Designation	Contact bridge	Capacities Main insulated Al-Cu (mm ²)	Capacities Tap insulated Al-Cu (mm ²)	Weight (kg)	Sales unit
ZINC-PLATED STEEL FASTENERS (ZF)						
K322	CONNECTOR CBS/CT 25 ZF - ERDF	Aluminium alloy	16-25	6-25 6M-35M	0.120	12
K323	CONNECTOR CBS/CT 70 ZF - ERDF	Aluminium alloy	16-70	6-25 6M-35M	0.120	12
K324	CONNECTOR CBS/CT 150 ZF - ERDF	Aluminium alloy	16-150	6-25 6M-35M	0.130	12
ZINC-PLATED STEEL FASTENERS (ZF)						
K331	CONNECTOR CBS/CT 70 ZF	Tinned brass	16-70	4-25	0.130	30
K332	CONNECTOR CBS/CT 95 ZF	Tinned brass	16-95	2.5-35	0.130	30
K330	CONNECTOR CBS/CT 150 ZF	Tinned brass	35-150	6-35	0.140	30
STAINLESS STEEL FASTENERS (SF) + YELLOW SHEAR HEAD INDICATOR						
K441	CONNECTOR CBS/CT 95 SF	Tinned brass	25-95	6-35	0.135	20
K442	CONNECTOR CBS/CT 150/1.5-25 SF	Tinned brass	35-150	1.5-25	0.140	20
K443	CONNECTOR CBS/CT 150/6-35 SF	Tinned brass	35-150	6-35	0.140	20

M means that the core of the conductor is solid.

Option: Service connector with movable seal cap

This connector is used for connecting the insulated service conductors to the low voltage A.B.C (Aerial Bundled Conductors). The movable sealing end cap enables a tap connection on the right or on the left. The main conductor connection and the tap ones use the insulation piercing technology.



Cap set-up for tap connection on the right



Cap set-up for tap connection on the left

Code	Designation	Contact bridge	Capacities Main insulated Al-Cu (mm ²)	Capacities Tap insulated Al-Cu (mm ²)	Weight (kg)	Sales unit
K532	CONNECTOR CBS/CT 95 ZF A	Tinned brass	16-95	2.5-35	0.115	20



SEE SHEET
INSTALLATION / LV insulated toolings

Service insulation piercing connector with Test Probe



K336

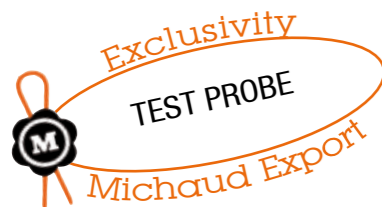

K338

with yellow shear head indicator

MICHAUD

Application

This connector is designed to connect the insulated service conductors to the low voltage A.B.C. (Aerial Bundled Conductors). It is equipped with a Test probe on the flexible sealing end cap. This enables the potential to be checked between 2 connectors installed on neutral and phase conductors and thus ensures good connection.

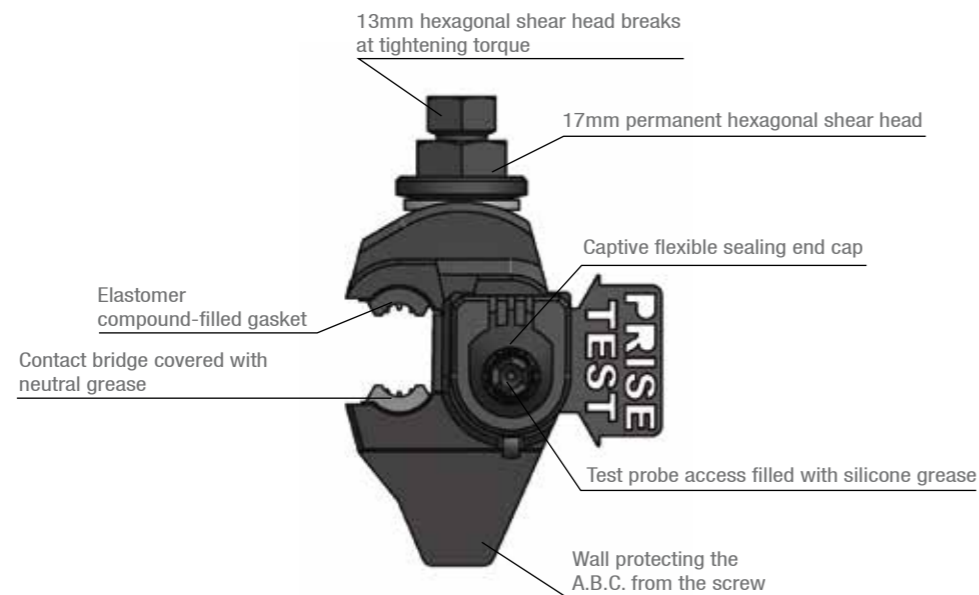

Description

- Insulation piercing is carried out on the main conductor and on the tap conductor simultaneously in a single tightening operation.
- The dielectric strength in water is greater than 6kV even after several piercings of the flexible end cap Test Probe using a standardised pin of a measuring device (3 to 5 times maximum).
- The tightening screw is potential free.
- Tightening efficiency is ensured by a shear head screw (nominal torque of 10Nm).
- The connector K338 is fitted with a yellow shear head indicator that disappears when head is sheared-off, being a clear visual confirmation of good tightening from ground level. It increases head height by 10 mm.
- The connector end cap is flexible so that to feel good tap conductor insertion simply by hand. It is glued on connector body so that to avoid eventual loss during handling, installation and environment (wind, bad weather...).

This connector meets the criteria of the **NF C 33-020** and **EN 50-483** standards.

Modified sealing end cap for test probe access:

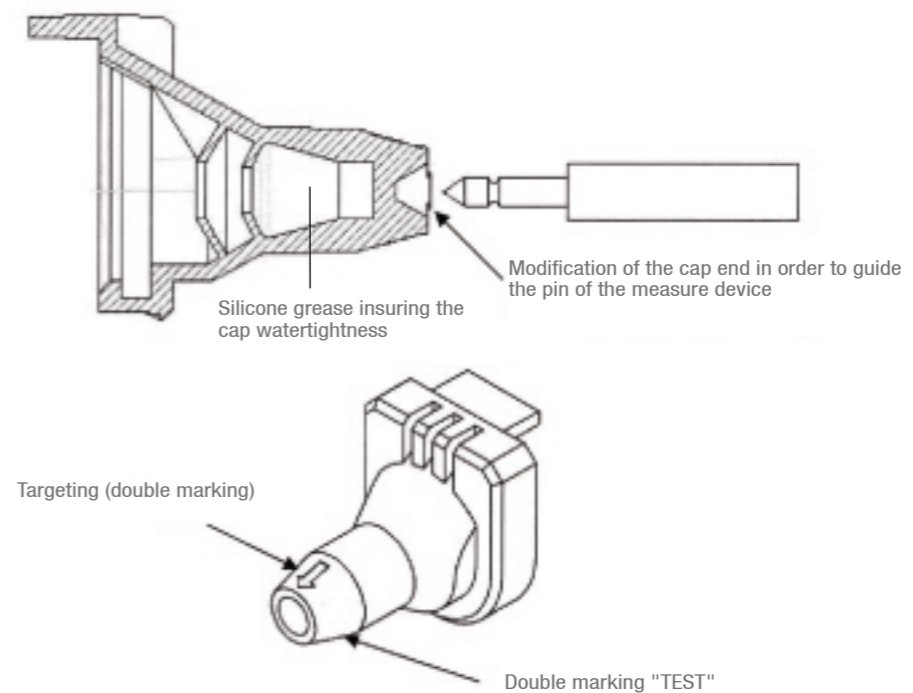

Installation

- Insert the insulated tap conductor into the connector so that its end seats in the flexible end cap.
- Use a 13mm spanner and tighten the connector on the insulated main conductor of the bundle until the shear head breaks.
- The 17mm permanent screw head is only provided for possible dismantling, and must not be used to re-tighten the screw after the 13mm head has broken.
- Installation can be carried out on a live line but with no load on the tap conductor.

Code	Designation	Contact bridge	Capacities Main insulated Al-Cu (mm ²)	Capacities Tap insulated Al-Cu (mm ²)	Weight (kg)	Sales unit
ZINC-PLATED STEEL FASTENERS (ZF)						
K336	CONNECTOR CBS/CT 95 TEST PROBE ZF	Tinned brass	16-95	4-35	0.135	10
K337	CONNECTOR CBS/CT 150 TEST PROBE ZF	Tinned brass	35-150	6-35	0.145	10
STAINLESS STEEL FASTENERS (SF) + YELLOW SHEAR HEAD INDICATOR						
K338	CONNECTOR CBS/CT 95 TEST PROBE SF	Tinned brass	16-95	4-35	0.135	10

SEE SHEET
INSTALLATION / LV insulated toolings

Service insulation piercing connector for bare conductor



K258

MICHAUD

Application

This connector is designed to connect the insulated service conductors to the low voltage overhead copper or aluminium alloy bare conductor network.

Two versions are available according to the type of conductor to be connected (Al or Cu):

- CNA (with aluminium alloy contact bridges),
- CNU (with rough brass contact bridges).



K470

with yellow shear head indicator

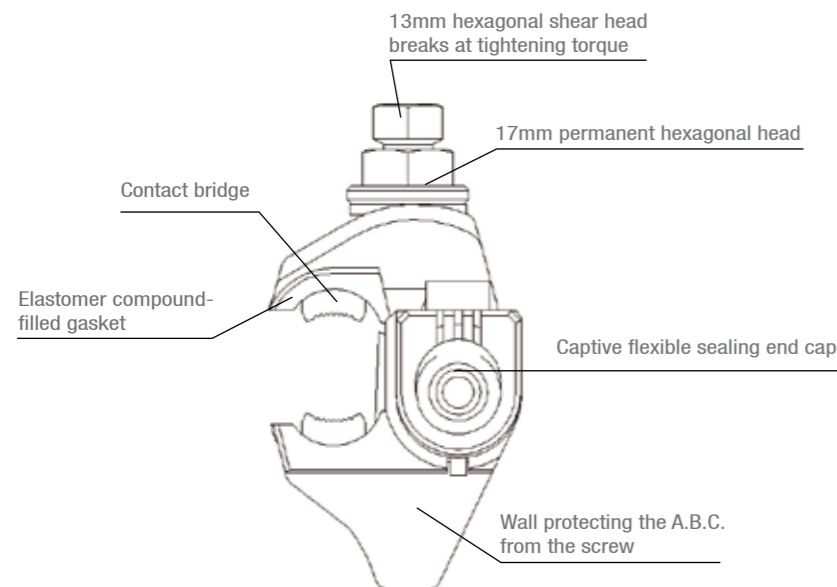

Description

Connector general features:

- Tightening of the bare main conductor and piercing of the tap conductor are carried out simultaneously in a single tightening operation.
- The tightening screw is potential free.
- Tightening efficiency is ensured by a shear head screw.
- Connectors K470 and K471 are fitted with a yellow shear head indicator that disappears when head is sheared-off, being a clear visual confirmation of good tightening from ground level. It increases head height by 10 mm.

This connector meets the criteria of the **NF C 33-020** and **EN 50-483** standards.

Connector end cap:

- The connector end cap is flexible so that to feel good tap conductor insertion simply by hand.
- It is carrying membranes instead of grease, granting watertightness around tap conductor end on long term basis.
- It is glued on connector body so that to avoid eventual loss during handling, installation and environment (wind, bad weather...).
- It can be equipped with a hard end cap, gripping and covering so, in case rigid cover is required. (Part Number K246 : please enquire for further information).

Installation

- Insert the insulated tap conductor into the connector so that its end seats in the flexible end cap.
- Use a 13mm spanner and tighten the connector on the bare main conductor until the shear head breaks.
- The 17mm permanent screw head is only provided for possible dismantling, and must not be used to re-tighten the screw after the 13mm head has broken.
- Installation can be carried out on a live line but with no load on the tap conductor.



Installation video available on www.michaud-export.com (tab Documentation > Installation videos)



Code	Designation	Contact bridge	Capacities Main bare (mm ²)	Capacities Tap insulated Al-Cu (mm ²)	Weight (kg)	Sales unit
ZINC-PLATED STEEL FASTENERS (ZF)						
K258	CONNECTOR RDP/CNU 95 ZF	Brass	Cu 7-95	6-35	0.150	20
K259	CONNECTOR RDP/CNA 95 ZF	Aluminium Alloy	Al 7-95	6-35	0.130	20
STAINLESS STEEL FASTENERS (SF) + YELLOW SHEAR HEAD INDICATOR						
K470	CONNECTOR RDP/CNU 95 SF	Brass	Cu 7-95	6-35	0.150	20
K471	CONNECTOR RDP/CNA 95 SF	Aluminium Alloy	Al 7-95	6-35	0.130	20

SEE SHEET
INSTALLATION / LV insulated toolings

Two stages bare conductor service connector

Exclusivity
TWO STAGES CONNECTION
Michaud Export



MICHAUD

Application

This connector designed to connect the insulated service conductors to the low voltage overhead aluminium alloy or copper bare conductor network. Two versions are available according to the type of conductor to be connected (Al or Cu). The tap and main cables are connected separately step by step to improve the electrical connection:

- 1. First the tap line is connected by piercing the insulation,**
- 2. Then the main line is connected.**

Installation can be carried out under a maximum load of 100A.

The benefit:

- + Connection under load

Description

Connector general features:

- Piercing of the tap line and tightening of the main conductor are carried out step by step in a single tightening operation.
- The tightening screw is potential free.
- Tightening efficiency is ensured by a shear head screw.
- This connector is fitted with a yellow shear head indicator that disappears when head is sheared-off, being a clear visual confirmation of good tightening from ground level. It increases head height by 10 mm.

This connector meets the criteria of the **NF C 33-020** and **EN 50-483** standards.

Connector end cap:

- The connector end cap is flexible so that to feel good tap conductor insertion simply by hand.
- It is carrying membranes instead of grease, granting watertightness around tap conductor end on long term basis.
- It is glued on connector body so that to avoid eventual loss during handling, installation and environment (wind, bad weather...).
- It can be equipped with a hard end cap, gripping and covering so, in case rigid cover is required. (Part Number K246 : please enquire for further information).

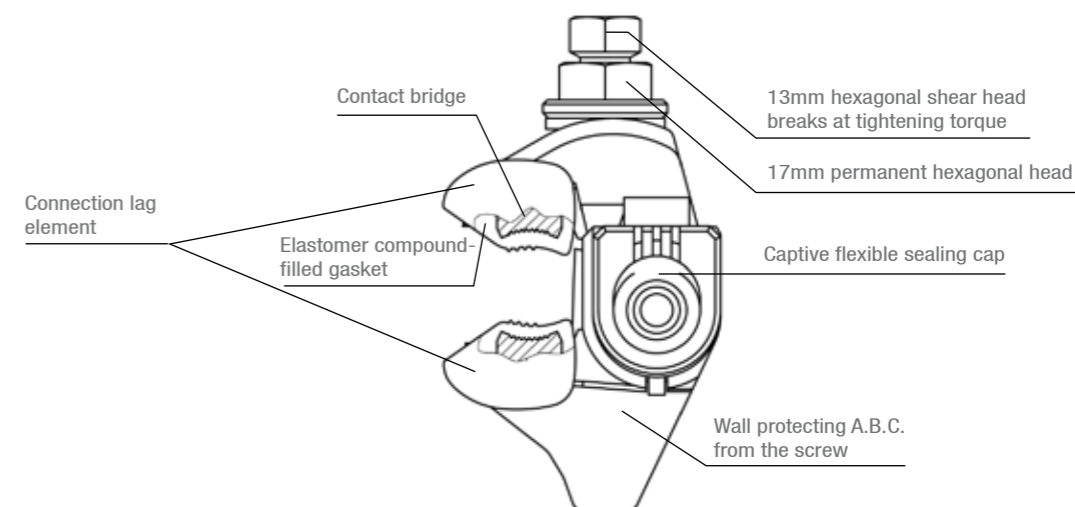

Installation

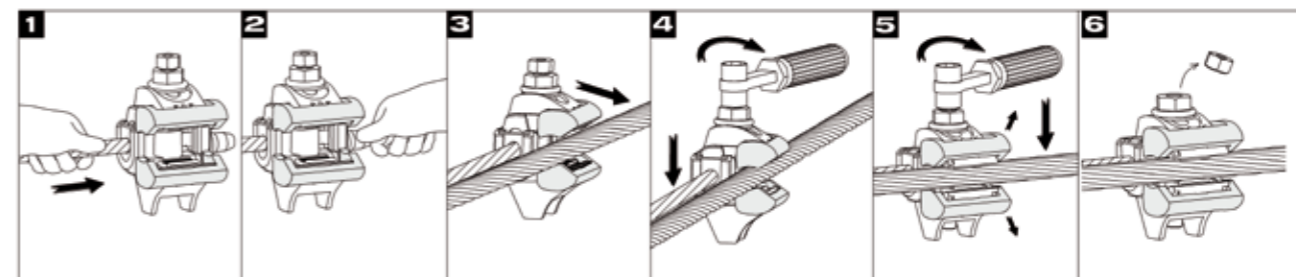

Insert the insulated service conductor into the connector so that its end seats in the flexible end cap. **1 2**
Install the connector correctly on the bare line. The conductor stays on the lag elements made of synthetic material. **3**
Note: The contact bridges remain away from the bare conductor.

Use a 13mm spanner and follow the two stage connection principle hereafter:

(a) Connection of the insulated tap cable:

- * The insulated tap conductor is connected by insulating piercing. **4**

(b) Connection of the bare main cable:

- * Tighten the connector on the bare conductor,
- * The lag elements are automatically pushed away and the bare main conductor is connected, **5**
- * Tighten the connector fully on to the bare conductor until the shear head breaks. **6**

The 17mm permanent screw head is only provided for possible dismantling. It must no be used to re-tighten the screw after the 13mm head has broken.

Installation can be carried out on a live line but with a maximum load of 100A on the tap conductor.

STAINLESS STEEL FASTENERS (SF) + YELLOW SHEAR HEAD INDICATOR

Code	Designation	Contact bridge	Capacities Main bare (mm)	Capacities Tap insulated Al-Cu (mm)	Weight (kg)	Sales unit
K235	2 STAGES CONNECTOR RDP/CNU 95 SF	Brass	Cu 7-95	6-35	0.170	4
K236	2 STAGES CONNECTOR RDP/CNA 95 SF	Aluminium Alloy	Al 7-95	6-35	0.170	4

SEE SHEET
INSTALLATION / LV insulated toolings

Service connector with independent tightening

Dismountable tap contact single service connector



K397

MICHAUD

Application

This connector designed to connect independently the insulated service conductors to the low voltage A.B.C. (Aerial Bundled Conductors). While connection of the main line conductor uses insulation piercing technology, that of the tap line uses stripping technology.

Description

- The dielectric strength in water is greater than 6kV.
- The tightening screws are potential free.
- Tightening efficiency is ensured by shear head screws.
- The independent tightening tap line can accommodate solid or stranded core aluminium or copper insulated conductors with sections between 2.5 and 35mm².

This connector meets the criteria of the **NF C 33-020** and **EN 50483** standards.

Installation

- Install the connector on the main conductor using a 13mm spanner until the shear head breaks.
- The 17mm permanent screw head is only provided for possible dismantling. It must not be used to re-tighten the screw after the 13mm head has broken.
- Strip the tap conductor over the recommended length and brush with neutral grease.
- Insert the conductor fully into the connector by piercing the seal wall.
- Tighten using a 13mm spanner until the shear head breaks.
- If dismantling and reassembling the tap, tighten the screw to the torque indicated on the head.
- It can be installed live. The load on the tap conductor must not exceed 90A.
- It can be disconnected live, but with no load.

ZINC-PLATED STEEL FASTENERS (VZ)						
Code	Designation	Contact bridge	Capacities Main insulated Al-Cu (mm ²)	Capacities Tap insulated Al-Cu (mm ²)	Weight (kg)	Sales unit
K397	PIERCING CONNECTOR CB 1d/CT 95	Tinned brass	16-95	2.5-35	0.175	6

Bare conductor service connector with independent tightening



K396

MICHAUD

Application

This connector is used for connecting independently the insulated service conductors to the low voltage overhead copper bare conductor network.

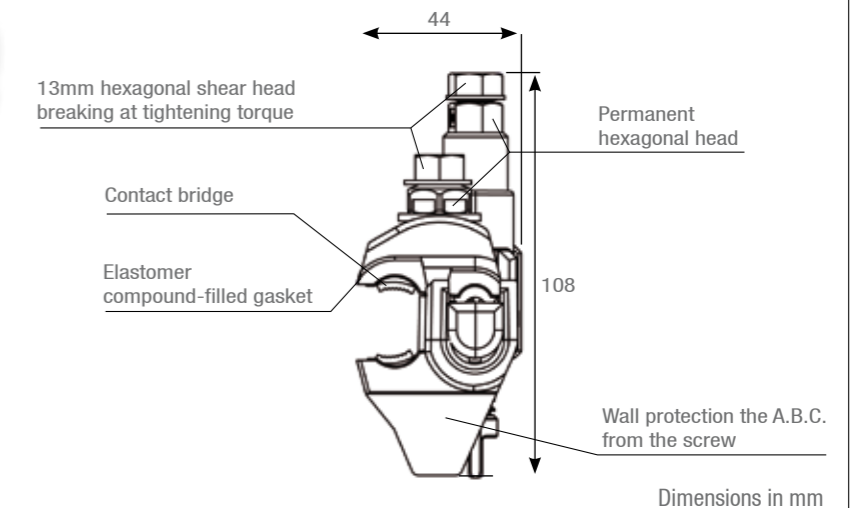

Description

- The tightening screws are potential free.
- Tightening efficiency is ensured by shear head screws.
- The independent tightening can accommodate solid or stranded core aluminium or copper insulated conductors with sections between 2.5 and 35mm².

This connector meets the criteria of **NF C 33-020**.

Installation

- Strip the tap conductor over the recommended length and brush with neutral grease.
- Insert the tap line fully, piercing the seal wall.
- Tighten using a 13mm spanner until the shear head breaks holding the tap line in your hand.
- Use a 13mm spanner and tighten the connector on the bare main conductor until the shear head breaks.
- The 17mm permanent screw head is only provided for possible dismantling. It must not be used to re-tighten the screw after the 13mm head has broken.
- Installation can be carried out on a live line but with no load on the tap conductor.
- If dismantling and reassembling the tap, tighten the screw to the torque indicated on the head.
- It can be disconnected live, but with no load.

ZINC-PLATED STEEL FASTENERS (VZ)						
Code	Designation	Contact bridge	Capacities Main bare (mm ²)	Capacities Tap insulated Al-Cu (mm ²)	Weight (kg)	Sales unit
K396	STRIPPING CONNECTOR RDP 1d/CNU 95	Brass	Cu 16-95	2.5-35	0.210	6

SEE SHEET
INSTALLATION / LV insulated toolings

Multitap service connector

2 tap conductors



K390

MICHAUD

Application

This connector is designed to connect from 2 to 4 insulated service conductors to the low voltage A.B.C. (Aerial Bundled Conductors).



K389

with yellow shear head indicator

4 tap conductors



K346

with yellow shear head indicator



K434

with yellow shear head indicator

Description

Connector general features:

- The dielectric strength in water is greater than 6kV.
- The tightening screws are potential free.
- Tightening efficiency is ensured by shear head screws.
- The tap conductor of K391 and K393 versions uses the stripping technology. It uses the insulation piercing technology for the other versions.
- This independent tightening tap conductor can accommodate solid or stranded core aluminium or copper insulated conductors with sections between 6 and 35mm².
- Connectors K389, K434 and K346 are fitted with a yellow shear head indicator that disappears when head is sheared-off, being a clear visual confirmation of good tightening from ground level. It increases head height by 10mm.

This connector meets the criteria of the **NF C 33-020** and **EN 50-483** standards.

Connector end cap (2 conductors):

- The connector end cap is flexible so that to feel good tap conductor insertion simply by hand.
- It is carrying membranes instead of grease, granting watertightness around tap conductor end on long term basis.
- It is glued on connector body so that to avoid eventual loss during handling, installation and environment (wind, bad weather...).
- It can be equipped with a hard end cap, gripping and covering so, in case rigid cover is required. (Part Number K246: please enquire for further information).

Code	Designation	Contact bridge	Capacities Main insulated Al-Cu (mm ²)	Capacities Tap insulated Al-Cu (mm ²)	Weight (kg)	Sales unit
ZINC-PLATED STEEL FASTENERS (ZF)						
K390	PIERCING CONNECTOR CB 2p/CT 150 ZF	Tinned copper	35-150	2 x 6-35	0.260	10
K391	STRIPPING CONNECTOR CB 2d/CT 150 ZF	Tinned copper	35-150	2 x 6-35	0.260	10
K392	PIERCING CONNECTOR CB 2p/CT 70 ZF	Tinned copper	16-70	2 x 6-35	0.260	10
K393	STRIPPING CONNECTOR CB 2d/CT 70 ZF	Tinned copper	16-70	2 x 6-35	0.260	10
K394	PIERCING CONNECTOR CB 2p/CT 95 ZF	Tinned copper	16-95	2 x 6-35	0.260	10
STAINLESS STEEL FASTENERS (SF) + YELLOW SHEAR HEAD INDICATOR						
K389	PIERCING CONNECTOR CB 2p/CT 150 SF	Tinned copper	35-150	2 x 6-35	0.260	10
K346	PIERCING CONNECTOR CB 4p/CT 95 SF	Tinned brass	25-95	4 x 6-35	0.300	20
K434	PIERCING CONNECTOR CB 4p/CT 150 SF	Tinned brass	35-150	4 x 6-35	0.380	10

Option: Service connector with movable seal cap

This connector is used for connecting 2 insulated service conductors to the low voltage A.B.C (Aerial Bundled Conductors). The movable seal cap enables a tap connection on the right or on the left. The main conductor connection and the tap ones use the insulation piercing technology.



Code	Designation	Contact bridge	Capacities Main insulated Al-Cu (mm ²)	Capacities Tap insulated Al-Cu (mm ²)	Weight (kg)	Sales unit
K594	PIERCING CONNECTOR CB 2p/CT 95 ZF A	Tinned brass	16-95	2 x 6-35	0.250	10

SEE SHEET
INSTALLATION / LV insulated toolings

Multitap aerial connection box

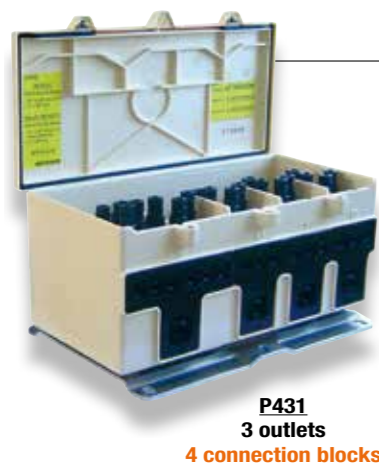

P431
3 outlets
4 connection blocks



P435
7 outlets
8 connection blocks

MICHAUD

Application

The box with 3 outlets is designed to establish up to 6 single phase connections or up to 3 three phase connections at one point of the low voltage aerial bundled network. The box with 7 outlets is designed to establish the junction of 2 overhead networks and the tap contact of 6 single phase or three phase connections maximum. These boxes can be installed on a façade or a pole. They can also be used at the network end.

The benefits:

- + Perform single phase or three phases connections
- + Better spread charges on the network, thanks to the connections visibility
- + Guarantee the network durability (better resistance to corrosion and humidity)
- + Reduce the number of connectors (safer network organisation, strengthened fraud-prevention)
- + Disconnect subscribers easily (network cable unimpacted, possibility to re-use connectors)
- + Check the potential at the connection terminals (with a test probe)
- + Guarantee a better fitters safety (electric shock risk limited)

Description

- The box with 3 outlets is equipped with 4 connection blocks (1 neutral + 3 phases). The "neutral block" consists of one inlet and 6 outlets: each "phase box" consists of one inlet and 3 outlets.
- The box with 7 outlets is equipped with 8 connection blocks.
- The network terminals use insulation piercing technology, and the service terminals use stripping technology. The connection blocks are linked 2 by 2 by linking bars.
- Each connection block is accessible with the contact pin of a test probe.
- The inlet and outlet of the conductors in the lower part are performed by elastomer seal sockets.
- The box is delivered with a metal integral fixing plate, which is resistant to corrosion. The rigidity of this plate allows it to be installed on uneven surfaces.
- The cover is closed using 2 stainless steel screws. An integrated device enables the assembly to be sealed and possibly padlocked.
- The terminal separators inside the box enable the conductors to be connected in any order.
- The degree of protection of the enclosure is IP43 (according to **NF EN 60529** standard). When the cover is open, the degree of protection of the live parts is IP2X.

This box meets the criteria of the **HN 62-S-33** standard.

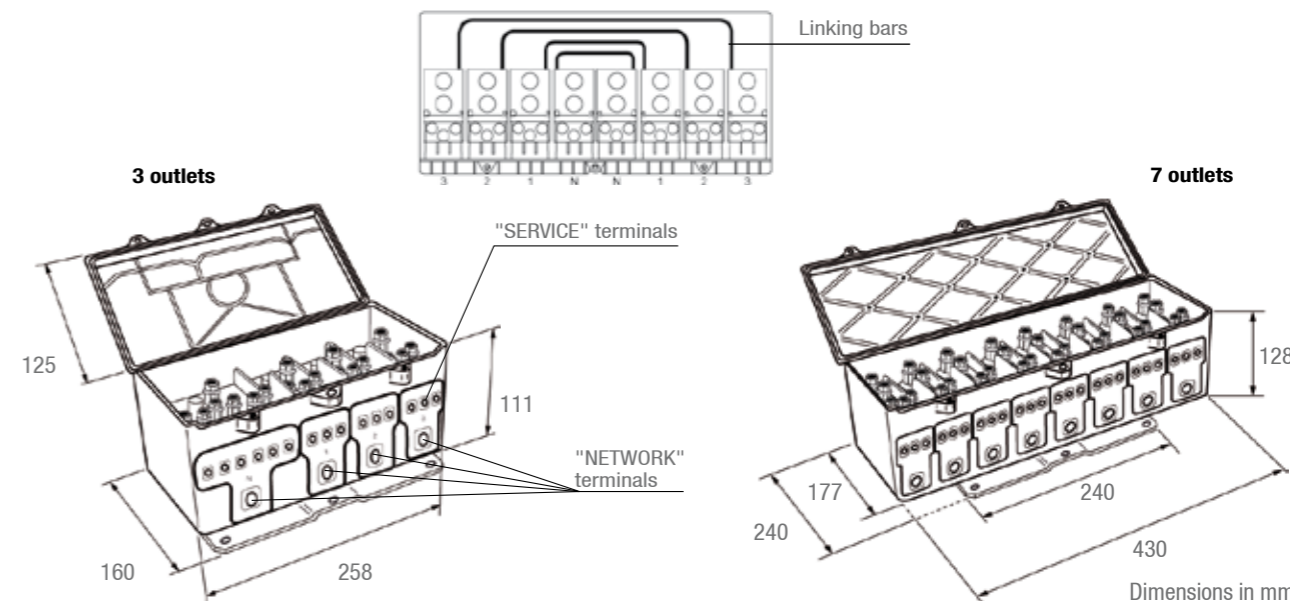

	Network	Service	Maximum flow power
P431	Capacity: 35mm ² - 150mm ² Al ou Cu Insulation piercing	Capacity: 10mm ² - 35mm ² Al ou Cu 16M - 50M Al Insulation piercing	110kVA
P432	Capacity: 35mm ² - 150mm ² Al ou Cu Stripping	Capacity: 6mm ² - 35mm ² Al ou Cu 16M - 50M Al Stripping	
P435	Capacity: 50mm ² - 150mm ² Al ou Cu Insulation piercing	Capacity: 10mm ² - 35mm ² Al ou Cu 16M - 50M Al Stripping	160kVA



Installation video available on www.michaud-export.com
(tab Documentation > Installation videos)



Code	Designation	Network terminals	Service terminals	Weight (kg)	Sales unit
P431	INSULATION PIERCING AERIAL CONNECTION BOX 3 OUTLETS	Insulation piercing	Insulation piercing	2.880	1
P432	STRIPPING AERIAL CONNECTION BOX 3 OUTLETS	Stripping	Stripping	2.780	1
P435	STRIPPING AERIAL CONNECTION BOX 7 OUTLETS	Insulation piercing	Stripping	6.090	1

Network insulation piercing connector



MICHAUD

Application

This connector is designed to connect a low voltage A.B.C. (Aerial Bundled Conductors) network to another network of the same type.

Description

Connector general features:

- Insulation piercing is carried out on the main and tap conductors simultaneously.
- The dielectric strength in water is greater than 6kV.
- The tightening screws are potential free.
- Tightening efficiency is ensured by shear head screws.
- Connectors K445, K354 and K446 are fitted with a yellow shear head indicator that disappears when head is sheared-off, being a clear visual confirmation of good tightening from ground level. It increases head height by 10 mm.

This connector meets the criteria of the **NF C 33-020** and **EN 50-483** standards.

Connector end cap:

- The connector end cap is flexible so that to feel good tap conductor insertion simply by hand.
- It is carrying membranes instead of grease, granting watertightness around tap conductor end on long term basis.
- It is glued on connector body so that to avoid eventual loss during handling, installation and environment (wind, bad weather...).
- It can be equipped with a hard end cap, gripping and covering so, in case rigid cover is required. (Part Number K245: please enquire for further information).

Installation

- Insert the insulated tap conductor into the connector so that its end seats in the flexible end cap. (Note: connector K 381 is delivered without a cap).
- Use a 17mm spanner (13mm for connectors K354, K355 and K356) and tighten the connector on the insulated conductor of the bundle until the shear head breaks.
- The 17mm permanent screw head (21mm for connector K381) is only provided for possible dismantling, and must not be used to re-tighten the screw after the first head has broken.
- Installation can be carried out on a live line but with no load on the tap conductor.

Hexagonal shear head breaks at tightening torque:
- H13/H17 (for K354 - K355 - K356),
- H17/H17 (for K365 - K366 - K445 - K446),
- H17/H21 (for K381)

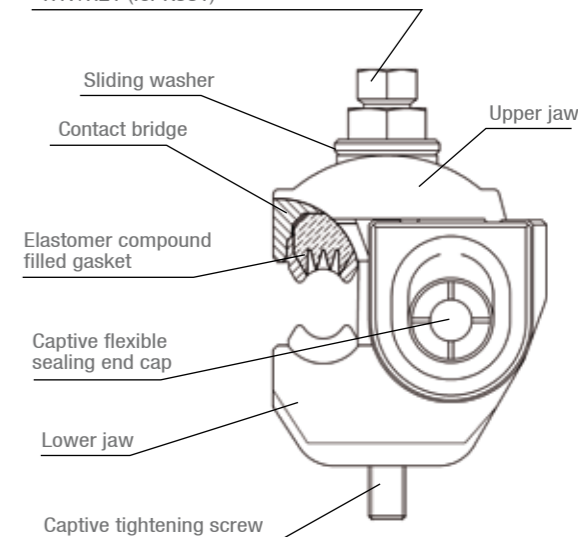

Code	Designation	Contact bridge	Capacities Main insulated Al-Cu (mm ²)	Capacities Tap insulated Al-Cu (mm ²)	Weight (kg)	Sales unit
ZINC-PLATED STEEL FASTENERS (ZF)						
K365	CONNECTOR CDRS/CT 95-95 ZF	Aluminium	25-95	25-95	0.235	20
K355	CONNECTOR CDRS/CT 150-95 ZF	Tinned brass	25-150	25-95	0.200	20
K366	CONNECTOR CDRS/CT AL 150-150 ZF	Aluminium	50-150	50-150	0.580	8
K356	CONNECTOR CDRS/CT 150-150 ZF	Tinned brass	35-150	35-150	0.400	10
K381	CONNECTOR CDRS/CT 240-240 ZF (without cap)	Tinned copper	50-240	50-240	0.820	1
K247	BLACK FLEXIBLE END CAP 95-240 - FOR CONNECTOR K381				0.027	6
STAINLESS STEEL FASTENERS (SF) + YELLOW SHEAR HEAD INDICATOR						
K445	CONNECTOR CDRS/CT 95-95 SF	Aluminium	25-95	25-95	0.230	20
K354	CONNECTOR CDRS/CT 150-95 SF	Aluminium	50-150	35-95	0.200	20
K446	CONNECTOR CDRS/CT 150-150 SF	Aluminium	50-150	50-150	0.560	8

Connector K356 is manufactured on order: please contact us.

Option: Connector with movable end cap

This connector is used for connecting the insulated service conductors to the low voltage A.B.C (Aerial Bundled Conductors). The movable sealing end cap enables a tap connection on the right or on the left. The main conductor connection and the tap ones use the insulation piercing technology.



ZINC-PLATED STEEL FASTENERS (ZF)						
Code	Designation	Contact bridge	Capacities Main insulated Al-Cu (mm ²)	Capacities Tap insulated Al-Cu (mm ²)	Weight (kg)	Sales unit
K555	CONNECTOR CDRS/CT 150-95 ZF	Tinned brass	25-150	25-95	0.174	20

SEE SHEET
OVERHEAD / LV end fitting / End cap

SEE SHEET
INSTALLATION / LV insulated toolings

Network insulation piercing connector for bare conductor



K254



K257



K472 - K473
with yellow shear head indicator



K474 - K475
with yellow shear head indicator

MICHAUD

Application

This connector is designed to connect a low voltage A.B.C. (Aerial Bundled Conductors) network to another low voltage aluminium alloy or copper bare conductors network.
The section of the bare conductors is from 7 to 240mm² depending on the model.
The section of the insulated cables is from 25 to 150mm² depending on the model.

Description

Connector general features:

- The tightening screws are potential free.
- Tightening efficiency is ensured by a shear head screw.
- Connection on the tap conductors is established using insulation piercing technology.
- Connectors K472, K473, K474 and K475 are fitted with a yellow shear head indicator that disappears when head is sheared-off, being a clear visual confirmation of good tightening from ground level. It increases head height by 10 mm.

This connector meets the criteria of the **NF C 33-020** and **EN 50-483** standards.

Connector end cap:

- The connector end cap is flexible so that to feel good tap conductor insertion simply by hand.
- It is carrying membranes instead of grease, granting watertightness around tap conductor end on long term basis.
- It is glued on connector body so that to avoid eventual loss during handling, installation and environment (wind, bad weather...).
- It can be equipped with a hard end cap, gripping and covering so, in case rigid cover is required. (Part Number K245: please enquire for further information).

Installation

- Insert the insulated tap conductor into the connector so that its end seats in the flexible end cap.
- Use a 13mm spanner for K254 - K257 or 17mm for K472 to K475. Tighten the connector on to the bare conductor until the shear head breaks.
- The 17mm hexagonal screw head is only provided for possible dismantling, and must not be used to re-tighten the screw after the first head has broken.
- Installation can be carried out on a live line but with no load on the tap conductor.

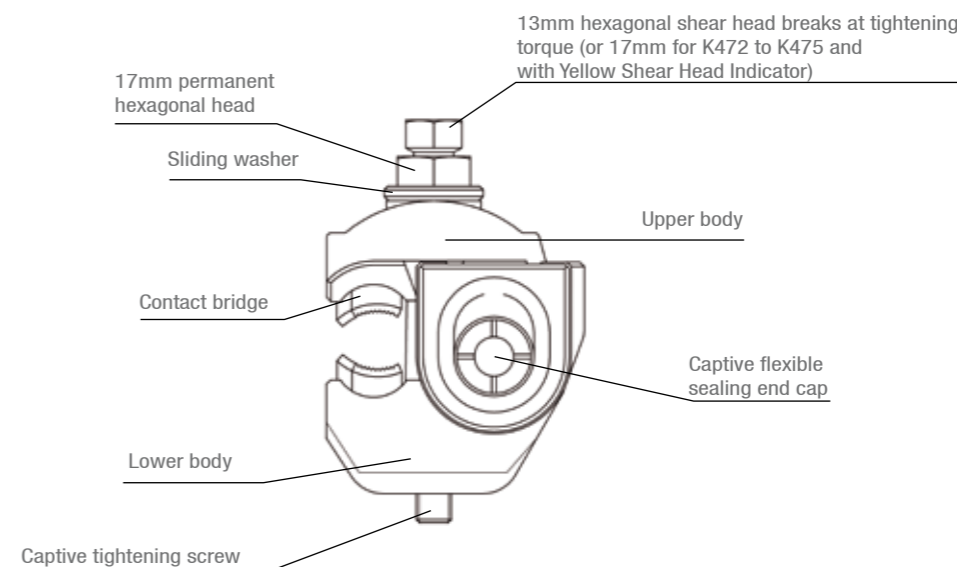

Code	Designation	Contact bridge	Capacities Main bare Al-Cu (mm ²)	Capacities Tap insulated Al-Cu (mm ²)	Weight (kg)	Sales unit
ZINC-PLATED STEEL FASTENERS (ZF)						
K254	CONNECTOR CDRSp/CN 120-70 ZF	Tinned brass	7-120	25-70	0.210	20
K257	CONNECTOR CDRSp/CN 120-150 ZF	Tinned brass	7-120	25-150	0.410	10
STAINLESS STEEL FASTENERS (SF) + YELLOW SHEAR HEAD INDICATOR						
K472	CONNECTOR RDP/CNU 120-95 SF	Copper Alloy	Cu 7-120	25-95	0.270	20
K473	CONNECTOR RDP/CNA 120-95 SF	Aluminium Alloy	Al 7-120	25-95	0.230	20
K474	CONNECTOR RDP/CNU 240-150 SF	Copper Alloy	Cu 50-240	35-150	0.640	8
K475	CONNECTOR RDP/CNA 240-150 SF	Aluminium Alloy	Al 50-240	35-150	0.550	8

These connectors can be connected to copper or aluminium alloy bare conductors.

SEE SHEET
INSTALLATION / LV insulated toolings

Network insulation piercing connector with dismantlable tap contact

MICHAUD

On A.B.C

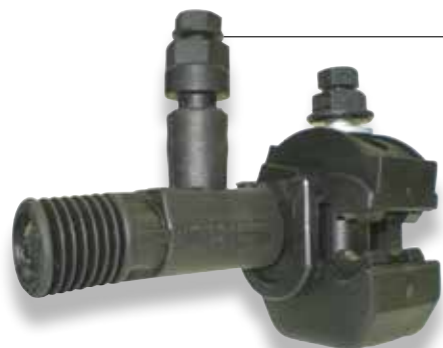

K342



K343 - K444

One bare conductor

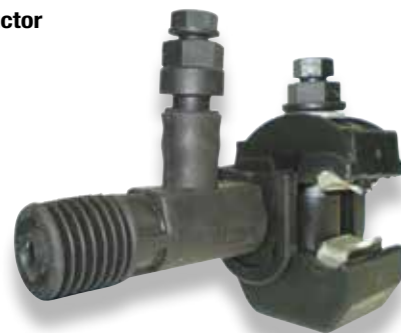

K376 - K378



K444
with yellow shear head indicator



K377 - K379

Application

This connector is designed to connect a low voltage A.B.C. (Aerial Bundled Conductors) to another network of the same type or to a low voltage aluminium alloy or copper bare conductors network.
In main line, the section of the insulated conductors is from 25 to 150mm² depending on the model, and is from 7 to 120mm² on bare conductors.
In tap line, the section of the insulated conductors is from 25 to 70mm² and from 35 to 150mm² depending on the model.

Description

- For the connection of the tap and for the connectors for insulated conductors, the dielectric strength in water is greater than 6kV.
- All of the tightening screws are potential free.
- Tightening efficiency is ensured by shear head screws.
- Connection on the main conductor is established with 1 or 2 shear head screws, depending on the model. This connection can be dismantled but not reused.
- Connection on the tap conductor is established after stripping its end with 1 or 2 shear head screw(s), depending on the model. It can be dismantled and reused.
- The connector K444 is fitted with a yellow shear head indicator that disappears when head is sheared-off, being a clear visual confirmation of good tightening from ground level. It increases head height by 10 mm.

This connector meets the criteria of the **NF C 33-020** and **EN 50-483** standards.

Details of the tap contact

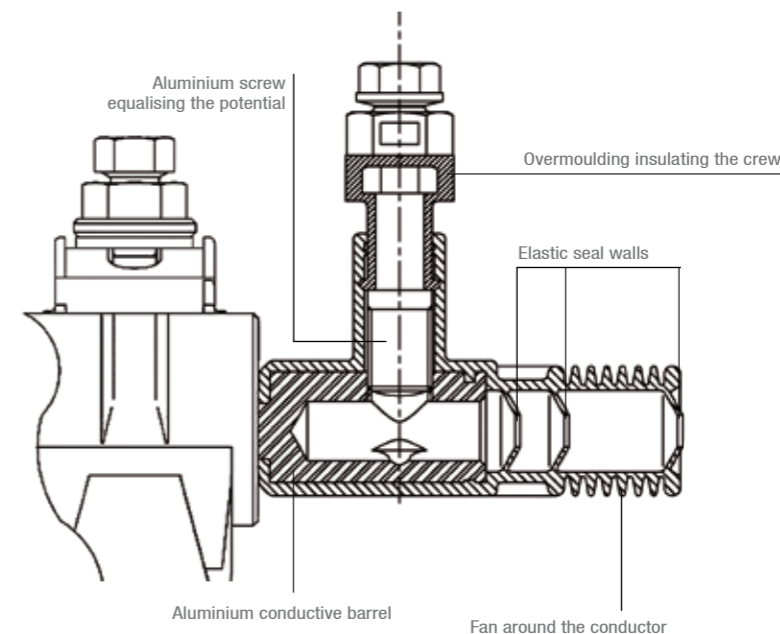

Installation

- Place the connector on the main conductor and tighten using a 13mm spanner until the shear head breaks.
- The 17mm permanent screw head is only provided for possible dismantling, and must not be used to re-tighten the screw after the first head has broken.
- Strip the tap conductor over the recommended length, insert it fully into the bore after brushing it with neutral grease.
- Tighten using a 13mm spanner until the shear head breaks (double screw on K377, K379 and K343).
- If dismantling and reassembling the tap, tighten the screw(s) using a 17mm spanner to the torque indicated on the head: 15Nm.
- Installation can be carried out on a live line but the load on the tap conductor must not exceed 60A.

Code	Designation	Contact bridge	Capacities Al-Cu (mm)		Weight (kg)	Sales unit
			Main	Tap		
ON A.B.C. INSULATED ZINC-PLATED STEEL FASTENERS (ZF)						
K342	CONNECTOR CDR/CT 2S 150-70 ZF	Tinned brass	25-150	25-70	0.260	10
K343	CONNECTOR CDR/CT 2S 150-150 ZF	Tinned brass	35-150	35-150	0.520	10
ON A.B.C. INSULATED STAINLESS STEEL FASTENERS (SF) + YELLOW SHEAR HEAD INDICATOR						
K444	CONNECTOR CDR/CT 2S 150-150 SF	Tinned brass	35-150	25-150	0.520	4
ON BARE CONDUCTOR ZINC-PLATED STEEL FASTENERS (ZF)						
K376	CONNECTOR CDR/CNA 2S 70 ZF	Tinned brass	7-120	25-70	0.280	10
K377	CONNECTOR CDR/CNA 2S 150 ZF	Tinned brass	7-120	35-150	0.530	10
K378	CONNECTOR CDR/CNU 2S 70 ZF	Tinned brass	7-120	25-70	0.280	10
K379	CONNECTOR CDR/CNU 2S 150 ZF	Copper alloy	7-120	35-150	0.530	10

SEE SHEET
INSTALLATION / LV insulated toolings

Parallel groove jaw



U558

Application

These parallel groove jaws are designed to connect a bare aluminium or copper line from another bare aluminium line. They are adapted to outside use.

Description

- The parallel groove jaws comprise an upper body and a lower body linked by 1 or 2 tightening screws.
- Jaws are designed to fit conductors shape.

Code	Designation	Capacities (mm ²)		Weight (kg)	Sales unit
		Main	Tap		
BARE ALUMINIUM					
U558-50	PARALLEL GROOVE JAW BARE AI 50	10-50	10-50	0.080	100
U558-90	PARALLEL GROOVE JAW BARE AI 90	20-90	20-90	0.100	100
U558-150	PARALLEL GROOVE JAW BARE AI 150	20-150	20-150	0.120	100
U558-185	PARALLEL GROOVE JAW BARE AI 185	35-185	35-185	0.130	100
BARE ALUMINIUM / COPPER					
U559-70/50	PARALLEL GROOVE JAW BARE AI/Cu 70 / 50	Al 16-70	Cu 6-50	0.100	100
U559-150/50	PARALLEL GROOVE JAW BARE AI/Cu 150 / 50	Al 25-150	Cu 10-50	0.120	100
U559-240/185	PARALLEL GROOVE JAW BARE AI/Cu 240 / 185	Al 35-240	Cu 16-185	0.130	100



Installation video available on www.michaud-export.com

To discover in this video: a range of connectors for overhead networks.



- In this video:**
- + Installation steps
 - + Tools required
 - + Technical characteristics

Street light insulation piercing connector



K439

MICHAUD

Application

This connector is designed to connect the street light insulated conductors to the low voltage A.B.C. (Aerial Bundled Conductors).



K326

10mm (K326) or 13mm (K439) hexagonal shear breaks at tightening torque

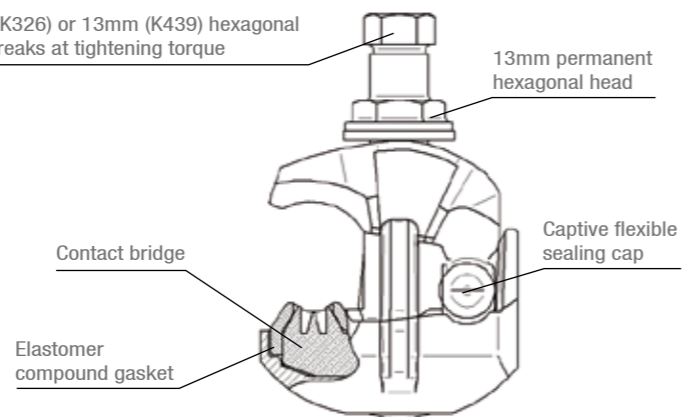

K440
with yellow shear head indicator

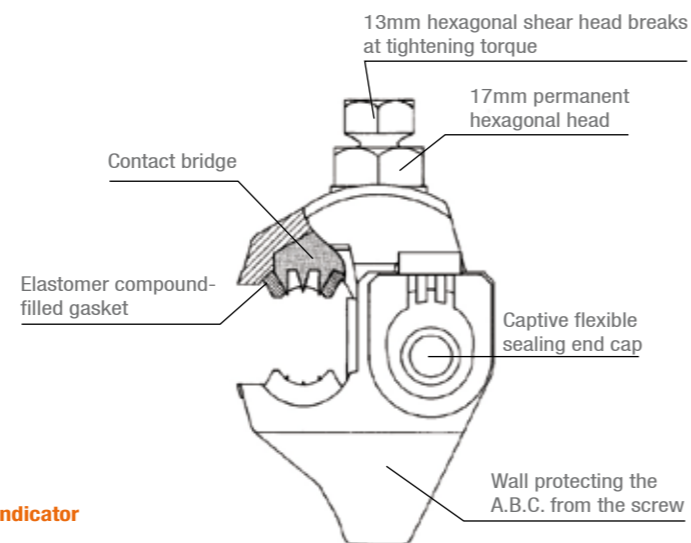

Description

- Insulation piercing is carried out on the main and tap conductors simultaneously in a single tightening operation.
- The dielectric strength in water is greater than 6kV.
- The tightening screw is potential free.
- Tightening efficiency is ensured by a shear head screw.
- The connector end cap is flexible so that to feel good tap conductor insertion simply by hand. It is glued on connector body or interdependent on watertightness, so that to avoid eventual loss during handling, installation and environment (wind, bad weather...).
- The connector K440 is fitted with a yellow shear head indicator that disappears when head is sheared-off, being a clear visual confirmation of good tightening from ground level. It increases head height by 10 mm.

This connector meets the criteria of the **NF C 33-020** and **EN 50-483** standards.

Installation

- Insert the insulated service conductor into the connector such that its end seats in the flexible end cap.
- Use a 10mm spanner (for the K326) or a 13mm spanner (for the K439 and K440) and tighten the connector on the insulated main conductor of the bundle until the shear head breaks.
- The 13mm (for the K326 and K439) or 17mm (for the K440) permanent screw head is only provided for possible dismantling, and must not be used to re-tighten the screw after the shear head has broken.
- Installation can be carried out on a live line but with no load on the tap conductor.



Code	Designation	Contact bridge	Capacities Main insulated Al-Cu (mm ²)	Capacities Tap insulated Al-Cu (mm ²)	Weight (kg)	Sales unit
ZINC-PLATED STEEL FASTENERS (ZF)						
K326	CONNECTOR CES/CT 70 ZF	Tinned brass	16-70	1.5-6	0.070	12
K439	CONNECTOR CES/CT 95 ZF	Tinned brass	10-95	1.5-6	0.060	50
STAINLESS STEEL FASTENERS (SF) + YELLOW SHEAR HEAD INDICATOR						
K440	CONNECTOR CES/CT 95 SF	Tinned brass	10-95	1.5-6	0.110	20

SEE SHEET
INSTALLATION / LV insulated toolings

SEE SHEET
PROTECTION / Service protection / Fuse switch connector 20A

Street light set



K416

MICHAUD

Application

This street light set is designed to interconnect a network with a street light installation inside a lighting column.

Description

- This set comprises:
 - 4 mechanical sleeves,
 - 1 protective cover.
- The mechanical sleeves are made of brass and accept up to 3 conductors of 10mm². The conductor(s) must be stripped over 17mm before installation. Tightening is ensured by two 4mm hollow hexagonal screws. Each sleeve is covered with a hard transparent synthetic material enclosure providing good protection during and after installation. The sleeves have an IP2X protection degree.
- The protective cover is made of impermeable synthetic materials. It is equipped with a watertight inlet seal on the upper part avoiding water penetration on the connector, and a cable tie on the lower part enabling the enclosure to perfectly fit network cables.

Installation

- 1 Insert the cable from the lighting column through the seal entrance.
- 2 Slide the enclosure upwards.
- 3 Implement the connectors.
- 4 Slide the enclosure down over the connectors.
- 5 Tighten the cable tie around the network cables.

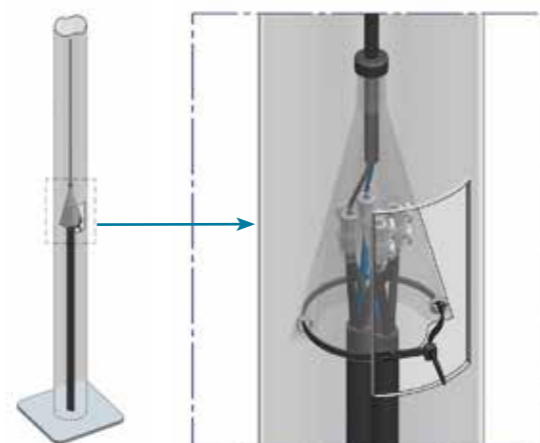

Lighting column

Code	Designation	Weight (kg)	Sales unit
K416	STREET LIGHT SET	0.350	10

Cold shrink end cap



P414

MICHAUD

Application

This end cap is designed to ensure street light conductor insulation when fitted at its end. It is mainly used on the bottom of lighting column.

Description

- The end cap is implemented without flame thanks to cold shrink technology.
- Depending on the model, it is made of an end cap with 4 or 5 movable guides enabling for correct conductors insertion.
- The material used is designed to ensure good UV resistance.
- Conductor capacity is 6-16mm² according to the **NF C 32-321** standard.

This product meets the criteria of the **HN 68-S-24** standard.

End installation

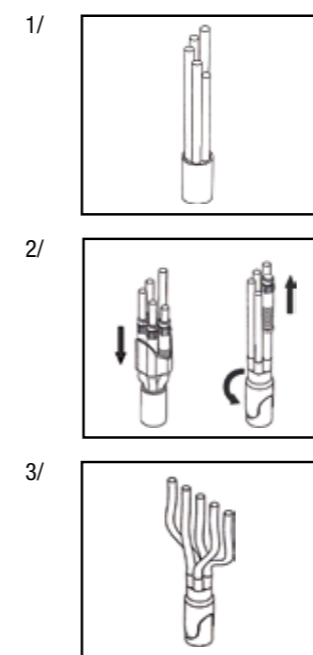

- Remove the sheath of the cable over the required length.
- Cut the conductors in a stair shape to facilitate assembly.

- Place the conductors from the longest to the shortest in the open guides.
- Fully insert the end cap.
- Turn over the end cap using the tabs.
- Remove the guides.

- Shape and cut the conductors to the required length.

Code	Designation	Weight (kg)	Sales unit
BC001	STREET LIGHT END CAP EE2TF 6-16	0.012	10
P415	STREET LIGHT END CAP EE3TF 6-16	0.012	10
P414	STREET LIGHT END CAP EE4TF 6-16	0.012	10
P419	STREET LIGHT END CAP EE5TF 6-16	0.012	10

Service cable dismantable sleeve and connection box

Service cable dismantable sleeve

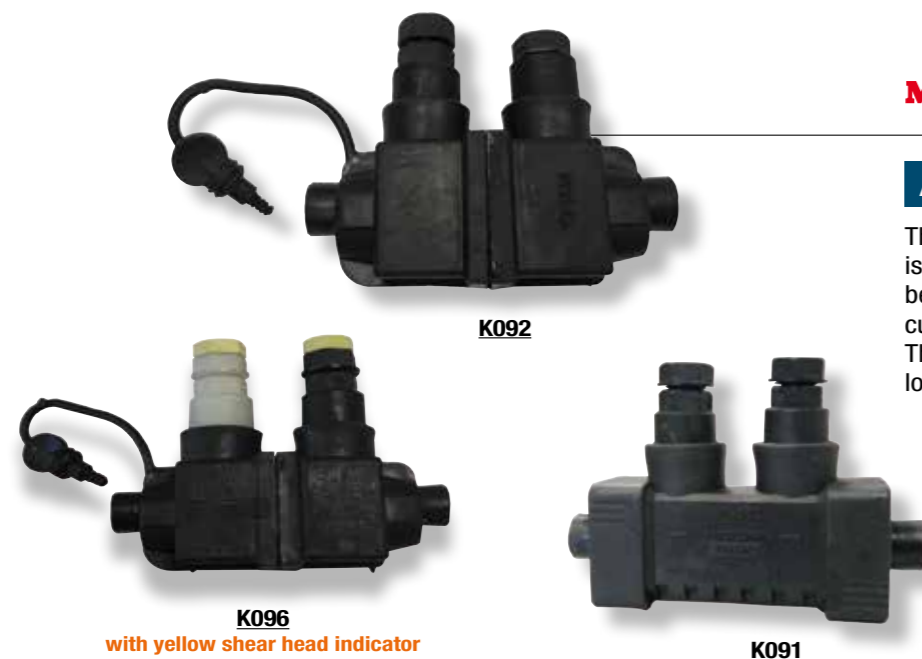

MICHAUD

Application

This service cable dismantable sleeve is designed to establish the connection between the aerial service cable to the customer cable with Al or Cu conductors. This sleeve is used in no mechanical load situation.

Description

- The sleeves K092 et K096 use the insulation piercing technology on the leading-in side (SUPPLY) and the stripping technology on the leading-out side (CUSTOMER).
- The sleeve K091 uses the insulation piercing technology on both sides.
- The dielectric strength in water is greater than 6kV.
- A flexible seal cap maintains the watertightness and insulation level on the stripping terminal in "disconnected" position for K092 and K096.
- The capacity of the terminals is 6-35mm²/16M-50M on the leading-in side (SUPPLY) and 4-35mm²/16M-50M on the leading-out side (CUSTOMER) depending on the models for K092 and K096.
- The capacity of terminals is 4-50mm² on both sides for K091.
- Installation of stripping terminals can be performed under a maximum load of 90A. Disconnection can be performed on a live line but with no load.
- The sleeves K092 and K096 can be assembled in a MCB (Mains Connection Box).
- The permanent hexagonal screw head on the "leading-in" side (SUPPLY), for the K096, allows possible dismantling. The permanent hexagonal screw head on the "leading-out" side (CUSTOMER) allows possible reuse.

This preinsulated sleeve meets the criteria of the **HN 33-S-83** standard.

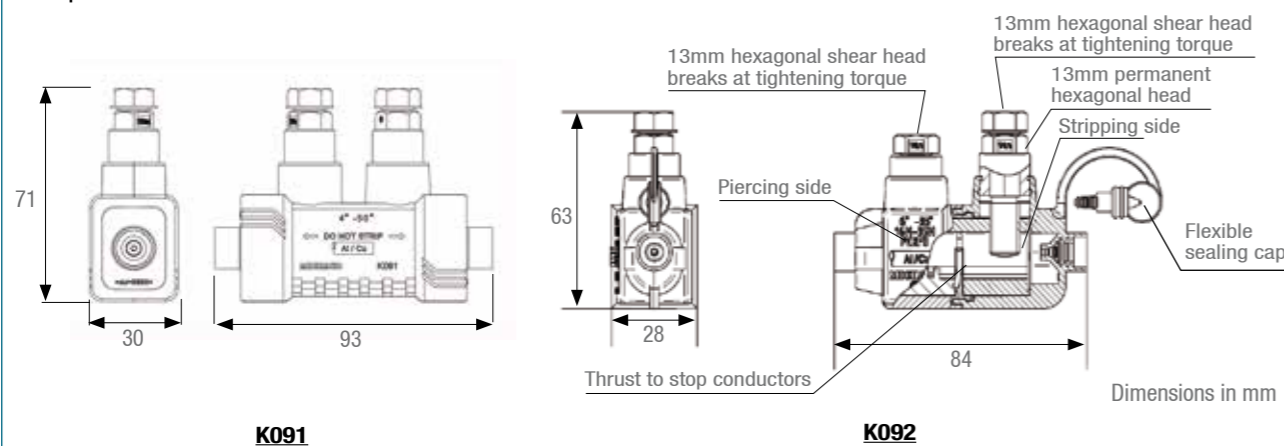

Installation video available on www.michaud-export.com (tab Documentation > Installation videos)

Code	Designation	Capacities		Weight (kg)	Sales unit
		Leading-in	Leading-out		
K091	DISMOUNTABLE SLEEVE PIERCING 4-50 / PIERCING 4-50	4-50	4-50	0.090	10
K092	DISMOUNTABLE SLEEVE PIERCING 6-50M / STRIPPING 6-50M	6-35mm ² 16M-50M	6-35mm ² 16M-50M	0.100	25
K096	DISMOUNTABLE SLEEVE PIERCING 6-35 / STRIPPING 4-35	6-35	4-35	0.090	10

M means that the core of the conductor is solid.

Connection box for dismantable sleeves



MICHAUD

Utilisation

This box is installed on the façade of the customer building. It includes service cable dismantable sleeves to connect the aerial service cable to the customer premise.

Description

- The boxes equipped with service cable dismantable sleeves are available in single phase or three phase versions.
- The service cable dismantable sleeves accept cable sections between 6 and 35mm² on the "leading-in" side (SUPPLY) and between 4 and 35mm² on the "leading-out" side (CUSTOMER).

Code	Designation	Weight (kg)	Sales unit
K451	SINGLE PHASE MCB + 2 K096	0.380	1
K455	THREE PHASE MCB + 4 K096	0.650	1

Variant: House service connector 4 bolts

This House Service Connector (HSC) with 4 bolts is designed to connect the overhead service line to the electrical installation of the premise. It receives aluminium/copper leading-in and copper leading-out cables, running through two separated chambers. It is installed outside or can be fitted in a no mechanical load situation into a MCB (Main Connection Box).



+ Safe neutral connection

Code	Designation	Network side (mm ²)	Customer side (mm ²)	Weight (kg)	Sales unit
K099	HSC PIERCING 6-35 / STRIPPING 4-35 / 4 BOLTS	6-35	4-35	0.167	5
L307	WHITE SHEAR HEAD SCREW FOR K099			0.016	10

Network preinsulated sleeve with mechanical tightening



Type 300
K569



Type 240
K191, K192, K193



Type 95
K189

MICHAUD

Application

This sleeve is designed to connect aluminium or copper conductors. It does not need the sectoral cores to be rounded before. It is implemented using a 13 or 17mm spanner. The electrical capacity is respectively 240mm² aluminium conductors (K191, K192), 150mm² aluminium or copper conductors (K193) and 95mm² aluminium or copper conductors (K189).

Description

- The dielectric strength in water is greater than 6kV.
- The materials are protected against UV and can be used outside.
- The 95 and 300 types accept round and sectoral sections in a single model.

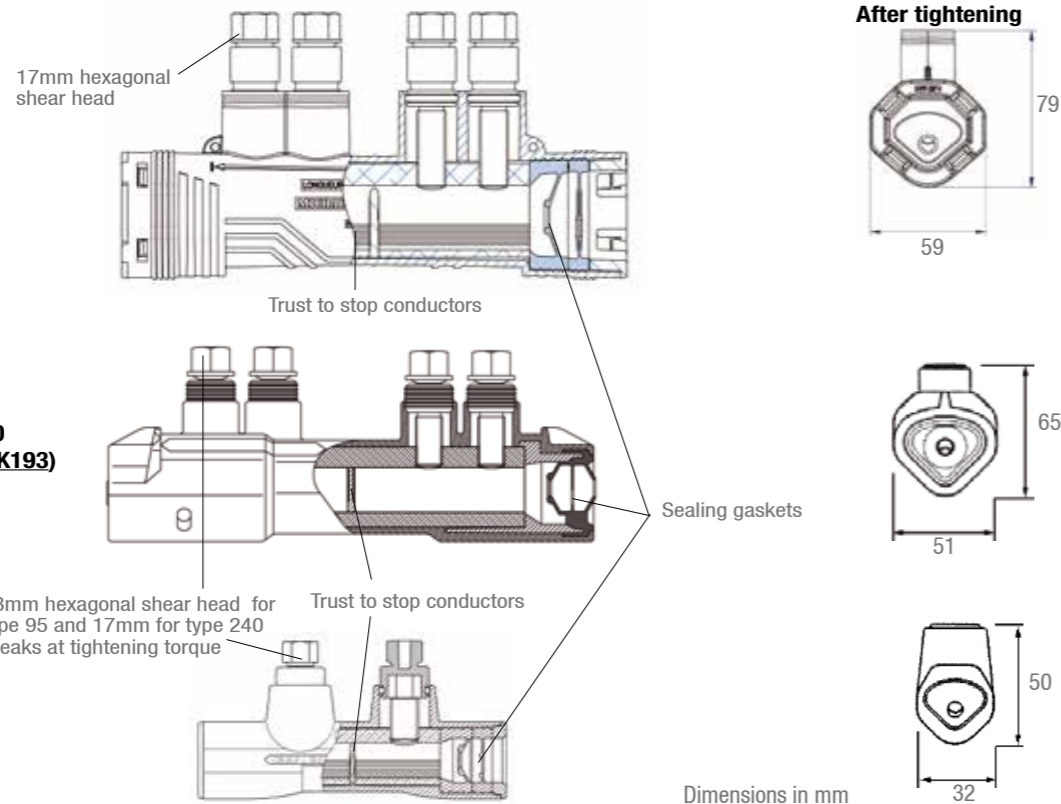

Installation video available on www.michaud-export.com
(tab Documentation > Installation videos)

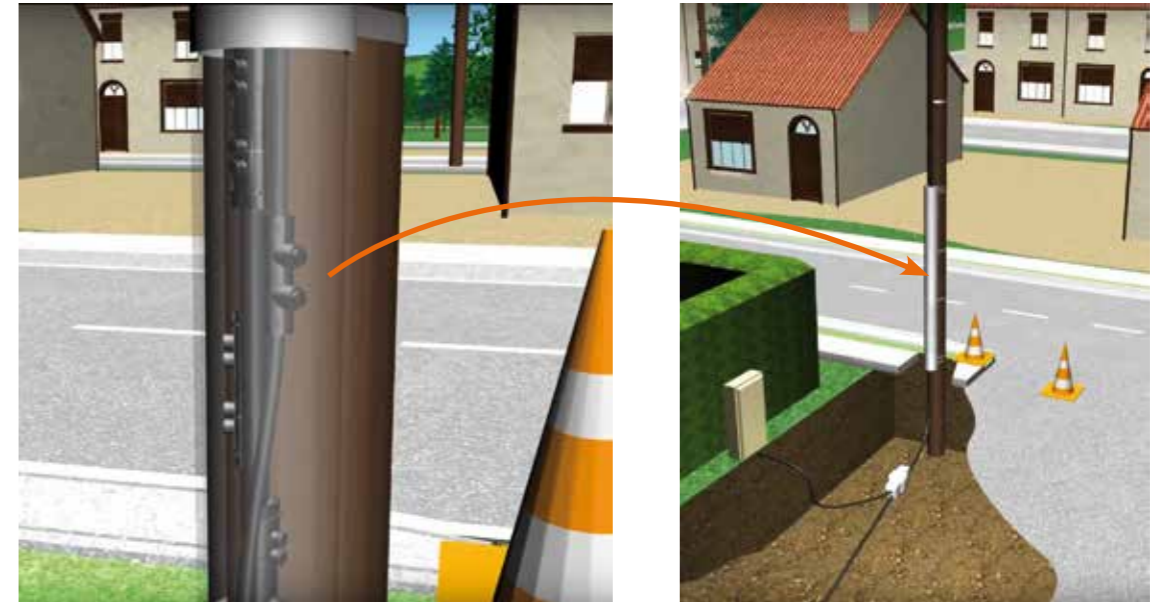

Code	Designation	Cable insulated Al-Cu (mm ²) *		Weight (kg)	Sales unit
		Leading-in	Leading-out		
K569	MECHANICAL SUBSURFACE PREINSULATED SLEEVE 150-300	Round/Sectoral 150 - 300	Round/Sectoral 150 - 300	0.700	4
K191	MECHANICAL SUBSURFACE PREINSULATED SLEEVE SECTORAL 95-240	Sectoral 95 - 240	Sectoral 95 - 240	0.520	4
K192	MECHANICAL SUBSURFACE PREINSULATED SLEEVE ROUND 150 / SECTORAL 240	Round 50 - 150	Sectoral 95 - 240	0.520	4
K193	MECHANICAL PREINSULATED SLEEVE ROUND 50-150	Round 50 - 150	Round 50 - 150	0.520	4
K189	MECHANICAL PREINSULATED SLEEVE 25-95	Round/Sectoral 25 - 95	Round/Sectoral 25 - 95	0.160	3

* Others cross sections are available : please contact us.

SEE SHEET
INSTALLATION / LV insulated toolings

Preinsulated sleeve E140

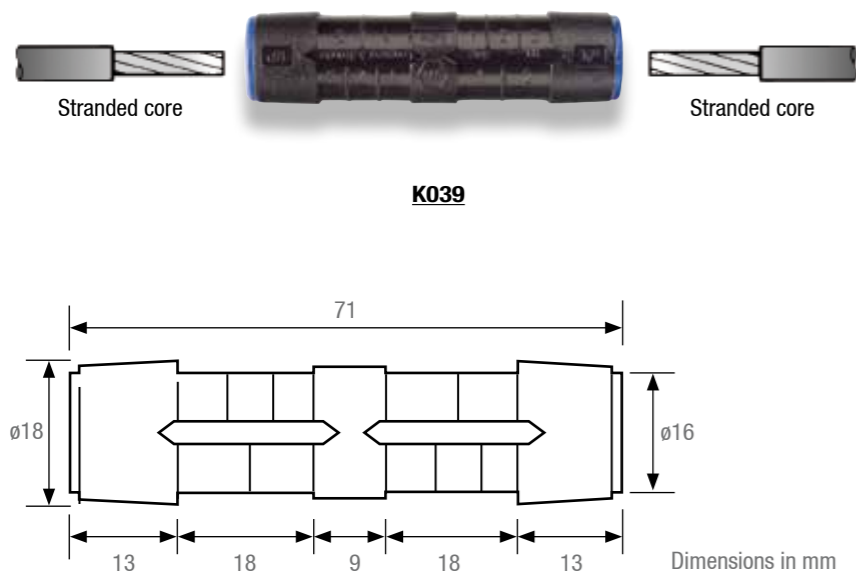

MICHAUD

Application

This preinsulated sleeve is designed for the connection of copper or aluminium stranded core overhead insulated conductors with traction or with no mechanical load. It is used for the installation, repair or modification of low voltage service lines. The junction can be established between two conductors of equal or unequal sections. All combinations of sections are possible. The section of the cables ranges goes from 6 up to 35mm².

Description

- The sleeve can be used in mechanical traction.
- The sleeve has got an excellent dielectric strength, greater than 6kV.
- The materials are protected against UV.

This preinsulated sleeve meets the requirements of the **NF C 33-021** and **EN 50-483** standards.

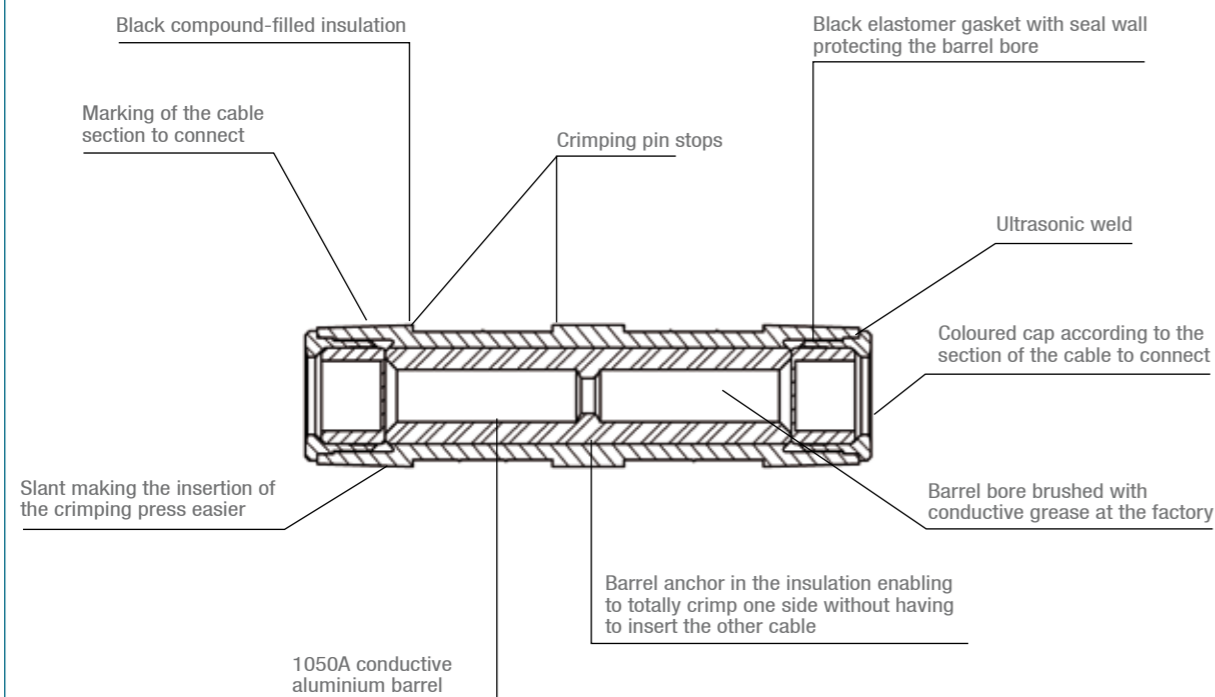

Installation

Preparation of the conductors to be connected:

- Cut the cables using a device that does not scratch the core.
- Strip the conductors over a length of 23mm.
- Brush the conductors to be connected using neutral grease to remove the oxide film. Do not wipe the conductors cleaned in this way.
- Insert the conductors fully into the sleeve bores.

Crimping:

- Both conductors do not need to be inserted before crimping. You can insert one, crimp it, insert the second one and crimp it.

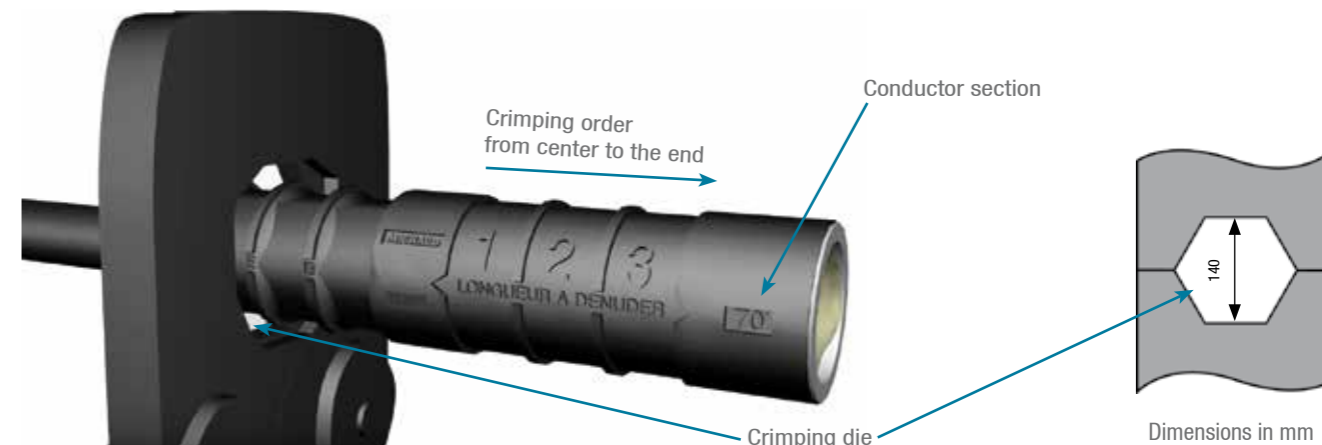

Installation video available on www.michaud-export.com (tab Documentation > Installation videos)

Code	Designation	Leading-in cable section (mm ²)	Leading-in colour	Leading-out cable section (mm ²)	Leading-out colour	Weight (kg)	Sales unit
K030	PREINSULATED SLEEVE (E140) MJPB 6	6	BROWN	6	BROWN	0.030	10
K031	PREINSULATED SLEEVE (E140) MJPB 10-6	10	GREEN	6	BROWN	0.030	10
K032	PREINSULATED SLEEVE (E140) MJPB 16-6	16	BLUE	6	BROWN	0.030	10
K033	PREINSULATED SLEEVE (E140) MJPB 25-6	25	ORANGE	6	BROWN	0.030	10
K035	PREINSULATED SLEEVE (E140) MJPB 10	10	GREEN	10	GREEN	0.030	10
K036	PREINSULATED SLEEVE (E140) MJPB 16-10	16	BLUE	10	GREEN	0.030	10
K037	PREINSULATED SLEEVE (E140) MJPB 25-10	25	ORANGE	10	GREEN	0.030	10
K039	PREINSULATED SLEEVE (E140) MJPB 16	16	BLUE	16	BLUE	0.030	10
K040	PREINSULATED SLEEVE (E140) MJPB 25-16	25	ORANGE	16	BLUE	0.030	10
K053	PREINSULATED SLEEVE (E140) MJPB 35-16	35	RED	16	BLUE	0.020	10
K042	PREINSULATED SLEEVE (E140) MJPB 25	25	ORANGE	25	ORANGE	0.020	10
K054	PREINSULATED SLEEVE (E140) MJPB 35-25	35	RED	25	ORANGE	0.020	10
K055	PREINSULATED SLEEVE (E140) MJPB 35	35	RED	35	RED	0.020	10



SEE SHEET
INSTALLATION / Hydraulic crimping tool

Preinsulated sleeve E173

MICHAUD

Application

This preinsulated sleeve is designed for the connection of insulated conductors of a low voltage overhead network to other ones.

The junction can be established between two conductors of equal or unequal sections. All combinations of sections are possible.

The neutral conductor is dimensioned to withstand tensile strength greater than 1 600daN for the 54mm² section and greater than 2 000daN for the 70mm² section.

The section of the cables ranges from 16mm² to 95mm².

Phase MJPT sleeve - **K110**



Neutral MJPT sleeve - **K116**



Description

- The sleeve can be used in mechanical traction.
- The sleeve has got an excellent dielectric strength, greater than 6kV.
- The materials are protected against UV.

This preinsulated sleeve meets the requirements of the **NF C 33-021** and **EN 50-483** standards.

Phase sleeve

Elastomer gasket with seal wall protecting the barrel bore

1050A conductive aluminium barrel

Coloured cap locating the conductor section to connect

104

ø22

ø20

Black compound-filled insulation

Barrel anchor in the insulation permitting to totally crimp one side without having to insert the other cable

Barrel bore brushed with conductive grease at the factory

Neutral sleeve

Conductive barrel in aluminium alloy

166

ø22

ø20

Insulation-barrel jointing anchorages

Discontinuity pin stop

Stuffing box collar in soft aluminium

Dimensions in mm

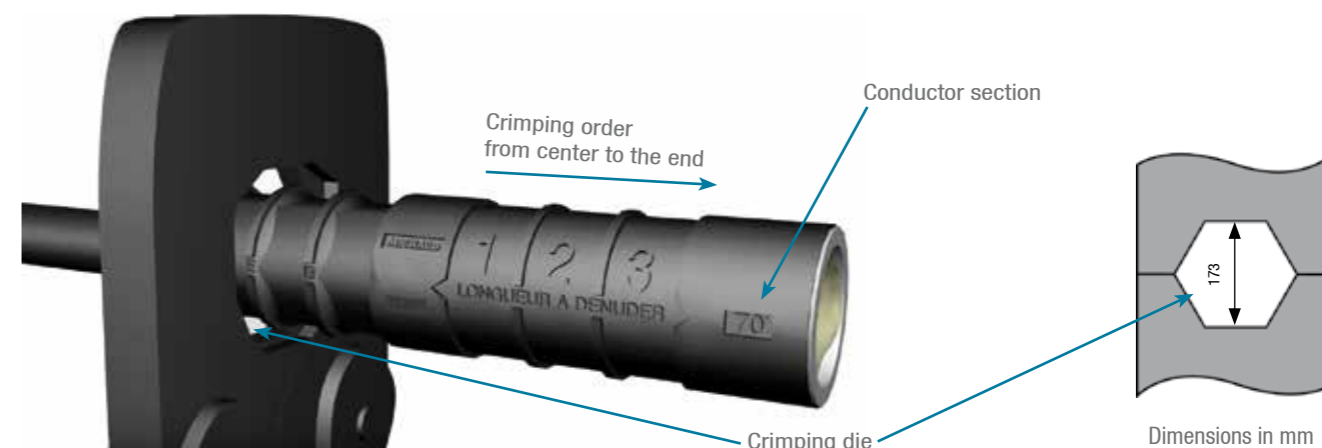

Installation video available on www.michaud-export.com (tab Documentation > Installation videos)

Code	Designation	Leading-in cable section insulated Al-Cu (mm ²)	Leading-in colour	Leading-out cable section insulated Al-Cu (mm ²)	Leading-out colour	Weight (kg)	Sales unit
PHASE SLEEVES							
K101	PREINSULATED SLEEVE (E173) MJPT 16	16	BLUE	16	BLUE	0.060	10
K103	PREINSULATED SLEEVE (E173) MJPT 25	25	ORANGE	25	ORANGE	0.060	10
K106	PREINSULATED SLEEVE (E173) MJPT 35	35	RED	35	RED	0.060	10
K108	PREINSULATED SLEEVE (E173) MJPT 50-25	50	YELLOW	25	ORANGE	0.060	10
K109	PREINSULATED SLEEVE (E173) MJPT 50-35	50	YELLOW	35	RED	0.060	10
K110	PREINSULATED SLEEVE (E173) MJPT 50	50	YELLOW	50	YELLOW	0.055	10
K114	PREINSULATED SLEEVE (E173) MJPT 54-50	54	BLACK	50	YELLOW	0.040	10
K118	PREINSULATED SLEEVE (E173) MJPT 70-35	70	WHITE	35	RED	0.050	10
K119	PREINSULATED SLEEVE (E173) MJPT 70-50	70	WHITE	50	YELLOW	0.050	10
K121	PREINSULATED SLEEVE (E173) MJPT 70	70	WHITE	70	WHITE	0.050	10
K122	PREINSULATED SLEEVE (E173) MJPT 95-70	95	GREY	70	WHITE	0.050	10
K123	PREINSULATED SLEEVE (E173) MJPT 95	95	GREY	95	GREY	0.050	10
NEUTRAL SLEEVES (FULL TRACTION)							
K115	PREINSULATED SLEEVE (E173) NEUTRAL MJPT 54	54.6N	BLACK	54.6N	BLACK	0.080	10
K117	PREINSULATED SLEEVE (E173) NEUTRAL MJPT 70-54	70N	WHITE	54.6N	BLACK	0.080	10
K116	PREINSULATED SLEEVE (E173) NEUTRAL MJPT 70	70N	WHITE	70N	WHITE	0.080	10

Variant: Sleeves set

Set comprising 3 phase sleeves and 1 neutral sleeve.

Code	Designation	A.B.C. to connect	Weight (kg)	Sales unit
K503	SET OF SLEEVES (E173) EJPT 35-54.6	3x35 + 54.6N on 3x35 + 54.6N	0.265	1
K504	SET OF SLEEVES (E173) EJPT 50-54.6	3x50 + 54.6N on 3x50 + 54.6N	0.260	1
K506	SET OF SLEEVES (E173) EJPT 70-35-54.6	3x70 + 54.6N on 3x35 + 54.6N	0.250	1
K505	SET OF SLEEVES (E173) EJPT 70-54.6	3x70 + 54.6N on 3x70 + 54.6N	0.240	1
K507	SET OF SLEEVES (E173) EJPT 70-50/54.6	3x70 + 54.6N on 3x50 + 54.6N	0.250	1
K700	SET OF SLEEVES (E173) EJPT 70/70-54.6	3x70 + 70N on 3x70 + 54.6N	0.240	1
K701	SET OF SLEEVES (E173) EJPT 70-70	3x70 + 70N on 3x70 + 70N	0.240	1
K699	SET OF SLEEVES (E173) EJPT 70-50/70-54.6	3x70 + 70N on 3x50+ 54.6N	0.255	1



SEE SHEET
INSTALLATION / Hydraulic crimping tool

Preinsulated sleeve E215

MICHAUD

Application

This preinsulated sleeve is designed for the connection of low voltage overhead insulated conductors to other ones. The junction can be established between two conductors of equal or unequal sections. All combinations of sections are possible. The section of the cables ranges from 95mm² to 150mm². The neutral conductor is dimensioned to withstand tensile strength greater than 1 530daN for the 95mm² and greater than 2 500daN for the 150mm² section.



Phase MJPT sleeve - **K175**



Neutral MJPT sleeve - **K185**

Description

- The sleeve can be used in mechanical traction.
- The sleeve has got an excellent dielectric strength, greater than 6kV.
- The materials are protected against UV.

This preinsulated sleeve meets the requirements of the **NF C 33-021** and **EN 50-483** standards.

PHASE SLEEVE

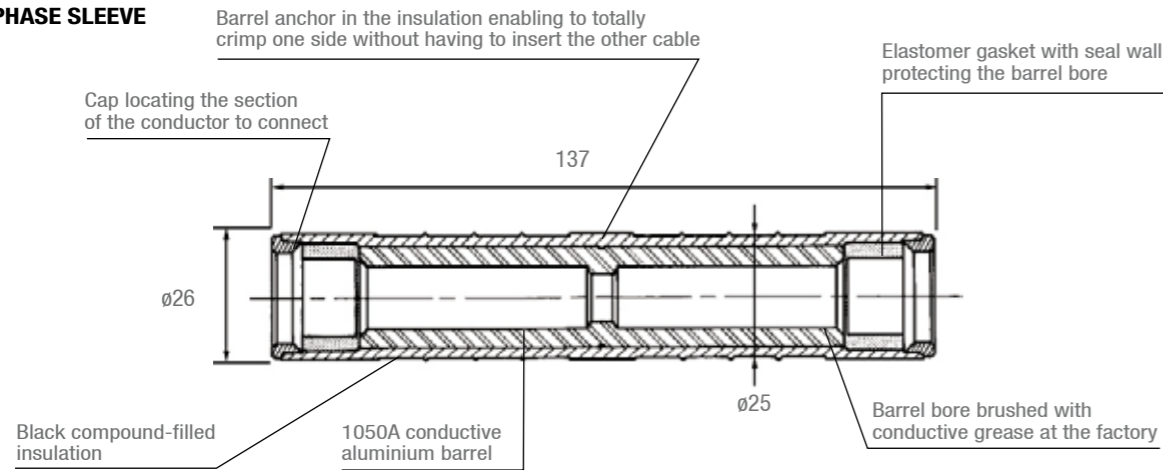

NEUTRAL SLEEVE

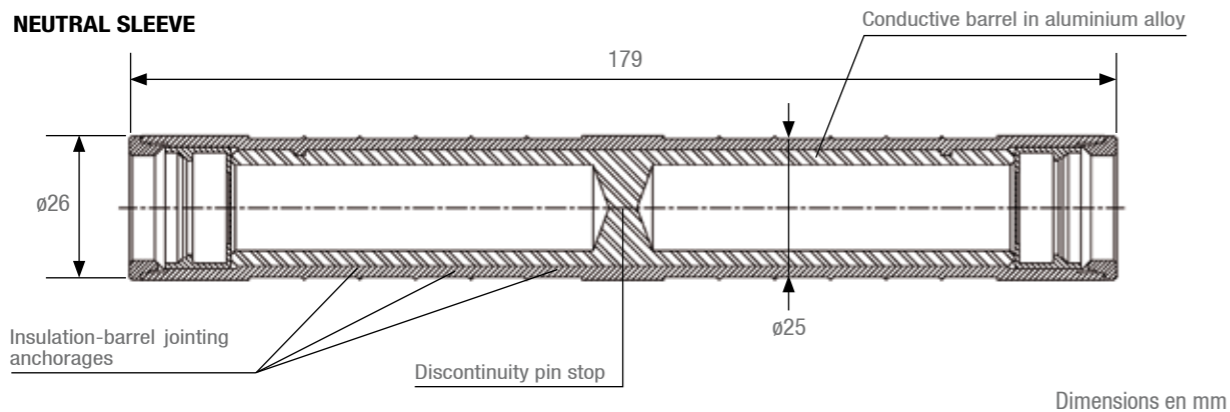

Installation

Preparation of the conductor to be connected:

- Cut the cable using a device that does not scratch the core.
- Strip the conductor over the length indicated on the sleeve.
- Brush the conductor to be connected using neutral grease to remove the oxide film. Do not wipe the conductor cleaned this way.
- Insert the conductor fully into the sleeve bore.

Crimping:

- Both conductors do not need to be inserted into the sleeve before the crimping operation. You can insert one, crimp it, insert the second one and crimp it.

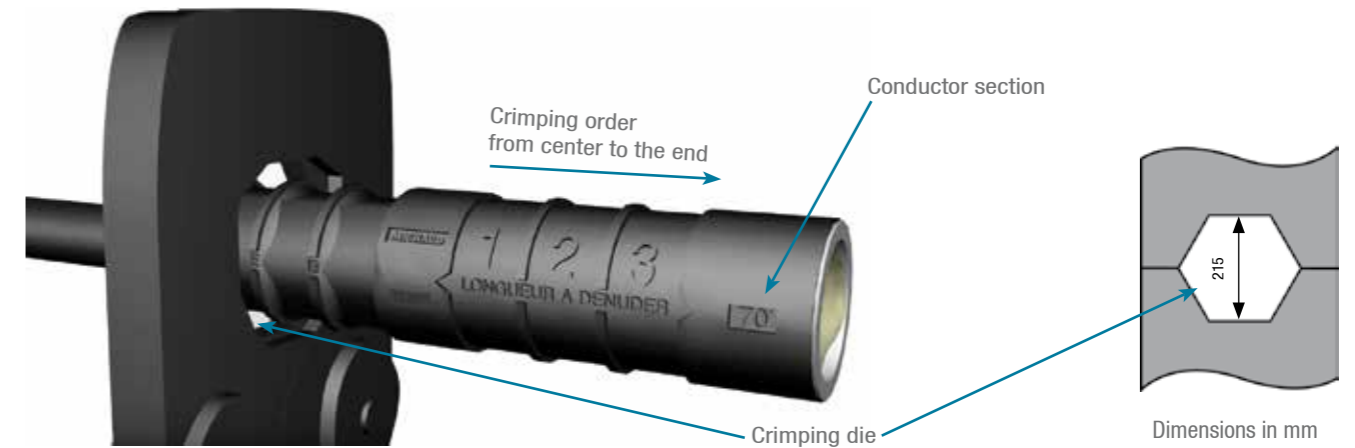

Installation video available on www.michaud-export.com (tab Documentation > Installation videos)

Code	Designation	Leading-in cable section insulated Al-Cu (mm ²)	Leading-in colour	Leading-out cable section insulated Al-Cu (mm ²)	Leading-out colour	Weight (kg)	Sales unit
PHASE SLEEVES							
K170	PREINSULATED SLEEVE (E215) MJPT 95	95	GREY	95	GREY	0.100	10
K188	PREINSULATED SLEEVE (E215) MJPT 120	120	PINK	120	PINK	0.090	10
K174	PREINSULATED SLEEVE (E215) MJPT 150-70	150	PURPLE	70	IVORY	0.100	10
K175	PREINSULATED SLEEVE (E215) MJPT 150	150	PURPLE	150	PURPLE	0.085	10
K176	PREINSULATED SLEEVE (E215) MJPT 150-95	150	PURPLE	95	GREY	0.090	10
NEUTRAL SLEEVES (FULL TRACTION)							
K182	PREINSULATED SLEEVE (E215) NEUTRAL MJPT 95 FT	95	GREY	95	GREY	0.100	10
K185	PREINSULATED SLEEVE (E215) NEUTRAL MJPT 150 FT	150	PURPLE	150	PURPLE	0.100	10

Variant: Sleeves set

Set comprising 3 phase sleeves (E215 crimped) and 1 neutral sleeve (E173 crimped).

Code	Designation	A.B.C. to connect	Weight (kg)	Sales unit
K509	SET OF SLEEVES (E215) EJPT 150-70/70-54.6	3x150 + 70N on 3x70 + 54.6N	0.380	1
K702	SET OF SLEEVES (E215) EJPT 150-70/70-70	3x150 + 70N on 3x70 + 70N	0.380	1
K510	SET OF SLEEVES (E215) EJPT 150-70/150-70	3x150 + 70N on 3x150 + 70N	0.350	1



SEE SHEET
INSTALLATION / Hydraulic crimping tool

Preinsulated sleeve for aerial sub-surface connection E140



MICHAUD

Application

This preinsulated sleeve is designed for the connection of stranded core aerial service cables (aluminium or copper) to aluminium solid core sub-surface service cables. It is also used to connect aluminium solid core service cables to one another. Cable sections up to 25mm² can be connected on the stranded core side and up to 35mm² on the solid core side.

Description

- The sleeve can be used in mechanical traction.
- The sleeve has got an excellent dielectric strength, greater than 6kV.
- The materials are protected against UV.

This preinsulated sleeve meets the requirements of the **NF C 33-021** and **EN 50-483** standards.

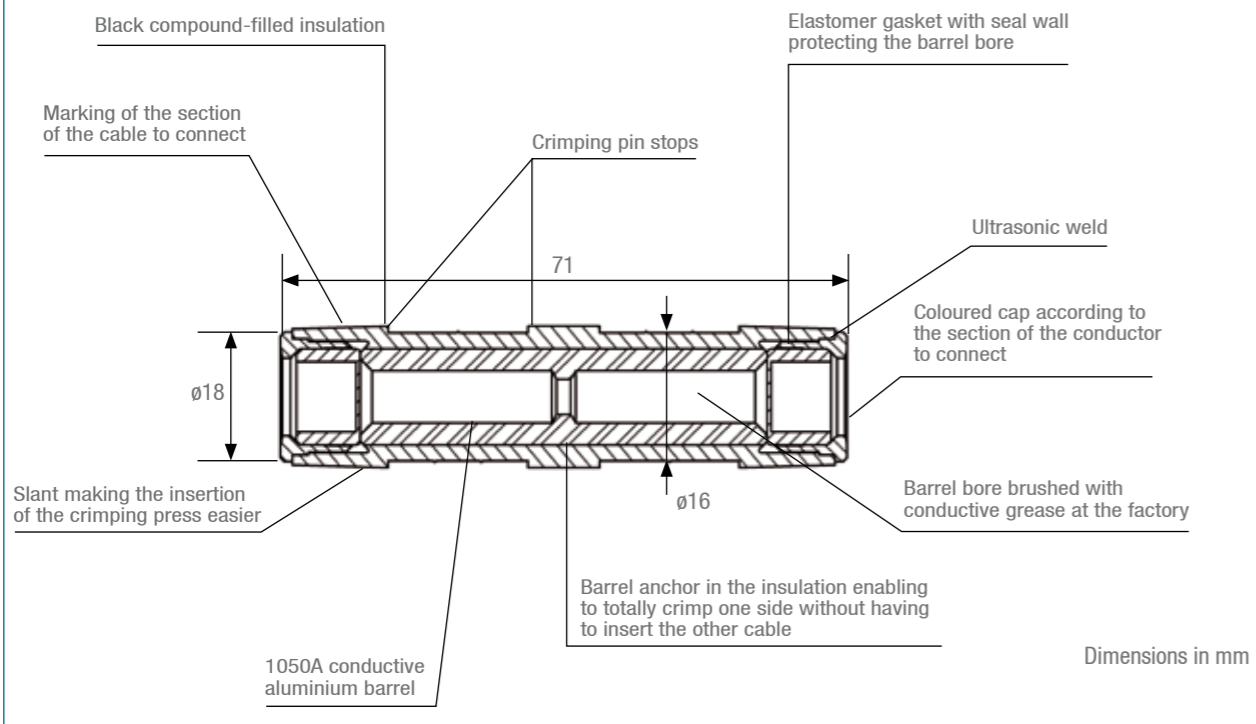

AERIAL SUB-SURFACE SLEEVES (CONNECTION OF A STRANDED CORE CABLE WITH A SOLID CORE CABLE)								
Code	Designation	Aerial cable insulated Al-Cu section (mm ²)	Aerial colour	Subsurface cable insulated Al (mm ²)	Subsurface colour		Weight (kg)	Sales unit
					Cap	Gasket		
K068	PREINSULATED SLEEVE (E140) MJPBAS 10-25M	10	GREEN	25 M	GREY	ORANGE	0.030	10
K069	PREINSULATED SLEEVE (E140) MJPBAS 10-35M	10	GREEN	35 M	GREY	RED	0.030	10
K064	PREINSULATED SLEEVE (E140) MJPBAS 16-4M	16	BLUE	4 M	GREY	BLACK	0.030	10
K065	PREINSULATED SLEEVE (E140) MJPBAS 16-6M	16	BLUE	6 M	GREY	BLACK	0.030	10
K070	PREINSULATED SLEEVE (E140) MJPBAS 16-16M	16	BLUE	16 M	GREY	BLUE	0.030	10
K078	PREINSULATED SLEEVE (E140) MJPBAS 16-25M	16	BLUE	25 M	GREY	ORANGE	0.030	10
K079	PREINSULATED SLEEVE (E140) MJPBAS 16-35M	16	BLUE	35 M	GREY	RED	0.030	10
K072	PREINSULATED SLEEVE (E140) MJPBAS 25-16M	25	ORANGE	16 M	GREY	BLUE	0.030	10
K074	PREINSULATED SLEEVE (E140) MJPBAS 25-25M	25	ORANGE	25 M	GREY	ORANGE	0.030	10
K076	PREINSULATED SLEEVE (E140) MJPBAS 25-35M	25	ORANGE	35 M	GREY	RED	0.030	10

M means that the core of the conductor is solid.

SUB-SURFACE SLEEVES (CONNECTION OF TWO SOLID CORE CABLES TO ONE ANOTHER)							
Code	Designation	Leading-in cable section insulated Al (mm ²)	Leading-out cable section insulated Al (mm ²)	Subsurface colour		Weight (kg)	Sales unit
				Cap	Gasket		
K085	PREINSULATED SLEEVE (E140) MJPBS 16M-35M	16 M	35 M	GREY	BLUE/RED	0.030	10
K073	PREINSULATED SLEEVE (E140) MJPBS 25M-25M	25 M	25 M	GREY	ORANGE/ORANGE	0.030	10
K086	PREINSULATED SLEEVE (E140) MJPBS 25M-35M	25 M	35 M	GREY	ORANGE/RED	0.030	10
K075	PREINSULATED SLEEVE (E140) MJPBS 35M-35M	35 M	35 M	GREY	RED/RED	0.030	10

M means that the core of the conductor is solid.

Variant:

Sleeves for neutral screen underground service cables (HM-27/03/139). They have a purple coloured cap on the copper side (21mm²).

Code	Designation	Poids (kg)	Unité vente
AERIAL/SUB-SURFACE SLEEVES			
K080	PREINSULATED SLEEVE (E140) MJPBAS 16-21Cu	0.030	10
K081	PREINSULATED SLEEVE (E140) MJPBAS 25-21Cu	0.030	10
SUB-SURFACE SLEEVES			
K082	PREINSULATED SLEEVE (E140) MJPBS 16M-21Cu	0.030	10
K083	PREINSULATED SLEEVE (E140) MJPBS 25M-21Cu	0.030	10
K084	PREINSULATED SLEEVE (E140) MJPBS 35M-21Cu	0.030	10
K087	PREINSULATED SLEEVE (E140) MJPBS 21Cu-21Cu	0.030	10

M means that the core of the conductor is solid.

SEE SHEET
INSTALLATION / Hydraulic crimping tool



Installation video available on www.michaud-export.com
(tab Documentation > Installation videos)

Preinsulated CPTAU lug



Spin-welded terminal lug



Crimped terminal lug

MICHAUD

Application

This preinsulated lug is designed to connect low voltage overhead insulated conductors to copper equipment terminals.
The cable sections range from 16 to 150mm² for the spin-welded terminal lug and 16 to 150mm² for the crimped lug.

Description

Spin-welded terminal lug

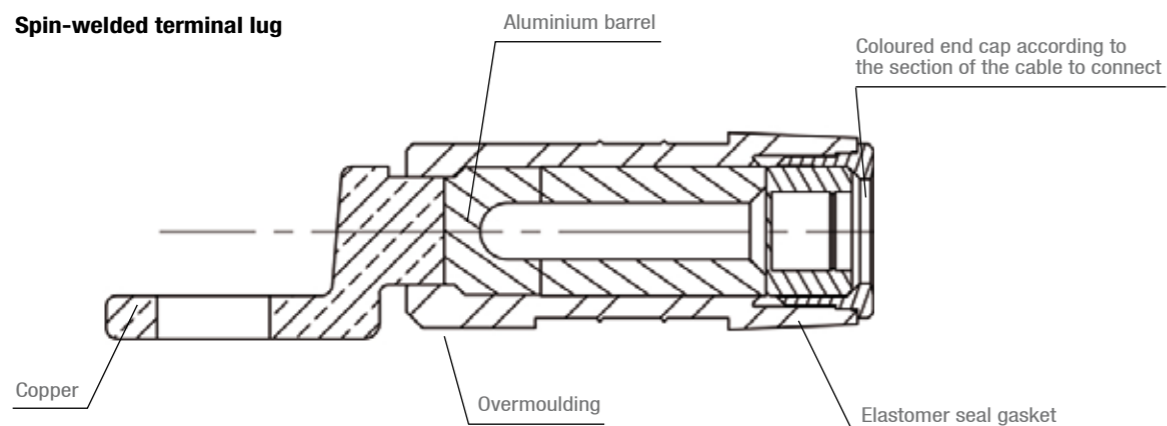

This preinsulated lug meets the requirements of the **NF C 33-021** and **EN 50-483** standards.

Crimped terminal lug

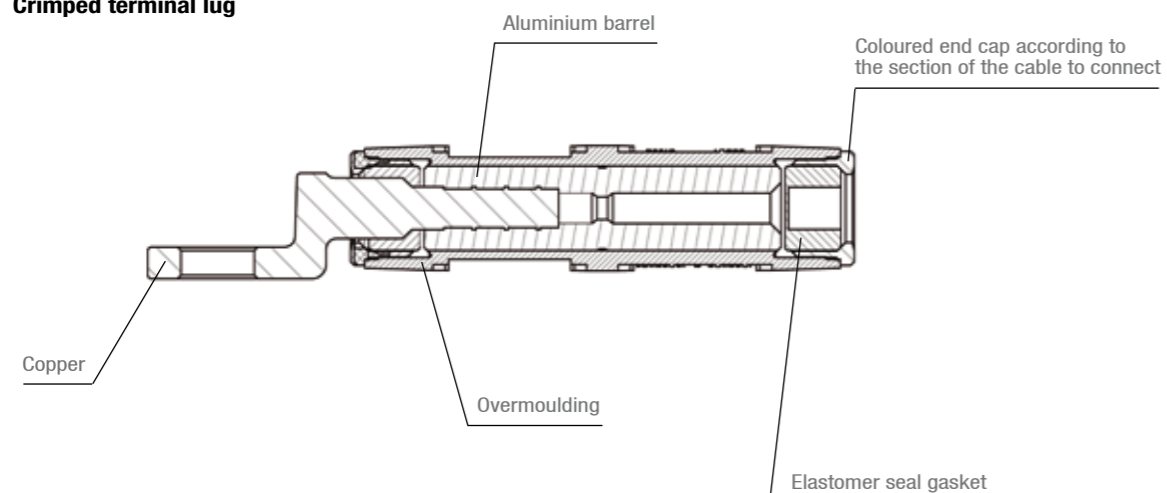

This preinsulated lug meets the requirements of the **NF C 33-021** and **EN 50-483** standards.

Installation

Crimping:

- Use a tool equipped with a suitable hexagonal die: E140 (14mm), E173 (17.3mm) or E215 (21.5mm).
- Crimp in the indicated area starting from the centre and going towards the end of the lug.

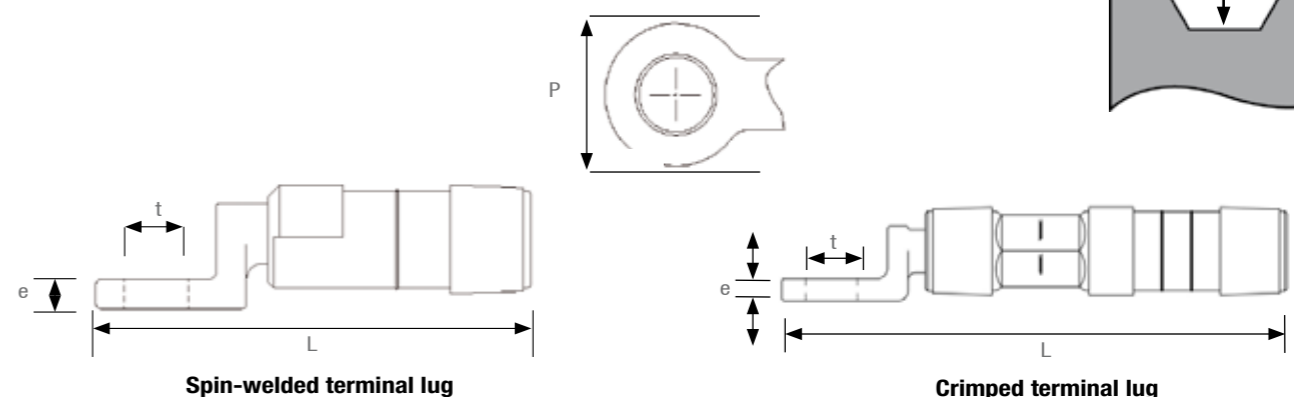

Code	Designation	Insulated Al-Cu cable (mm ²)	Dimensions in mm				Weight (kg)	Sales unit
			P	e	t	L		
SPIN-WELDED PREINSULATED LUG REQUIRING A E140 CRIMPING DIE								
K159	Cu TERMINAL LUG (E140) CPTAU 16	16	20	5	10.3	72	0.040	10
K160	Cu TERMINAL LUG (E140) CPTAU 25	25	20	5	10.3	72	0.040	10
SPIN-WELDED PREINSULATED LUG REQUIRING A E173 CRIMPING DIE								
K163	Cu TERMINAL LUG (E173) CPTAU 35	35	25	5	12.8	92	0.070	10
K164	Cu TERMINAL LUG (E173) CPTAU 50	50	25	5	12.8	92	0.070	10
K165	Cu TERMINAL LUG (E173) CPTAU 54	54	25	5	12.8	92	0.070	10
K166	Cu TERMINAL LUG (E173) CPTAU 70	70	25	5	12.8	92	0.070	10
K167	Cu TERMINAL LUG (E173) CPTAU 95	95	25	5	12.8	92	0.070	10
SPIN-WELDED PREINSULATED LUG REQUIRING A E215 CRIMPING DIE								
K024	Cu TERMINAL LUG (E215) CPTAU 150	150	30	6	13	118	0.120	10
CRIMPED PREINSULATED LUG REQUIRING A E140 CRIMPING DIE								
K013	Cu CRIMPED TERMINAL LUG (E140) CPTAU 25	25	20	4.5	10.5	102	0.055	10
CRIMPED PREINSULATED LUG REQUIRING A E173 CRIMPING DIE								
K017	Cu CRIMPED TERMINAL LUG (E173) CPTAU 54	54	25	5	13	142	0.120	10
K018	Cu CRIMPED TERMINAL LUG (E173) CPTAU 70	70	25	5	13	142	0.110	10
CRIMPED PREINSULATED LUG REQUIRING A E215 CRIMPING DIE								
K021	Cu CRIMPED TERMINAL LUG (E215) CPTAU 120	120	30	6	13	186	0.220	10
K023	Cu CRIMPED TERMINAL LUG (E215) CPTAU 150	150	30	6	13	186	0.220	10

SEE SHEET
INSTALLATION / Hydraulic crimping tool

Bare lug

Tubular lug



MIRELEC

Application

This tubular lug is designed to connect cable. It is made of tinned copper (by electrolysis). It is manufactured with an inspection hole and socketing. This lug is implemented with hexagonal compressed connection. This lug meets the requirement of the **NFC 20-130** standard.

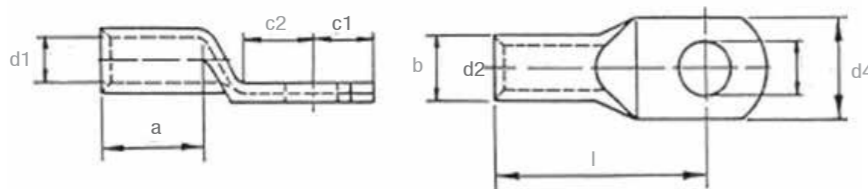

Code	Designation	Dimensions (mm)								Bore	Weight (kg)	Sales unit
		d1	a	b	d2	d4	c1	c2	l			
U744-6	TUBULAR LUG 10 ² -6	4.2	12	12	6.5	6.8	6.5	7.5	24	M6	0.020	100
U745-6	TUBULAR LUG 16 ² -6	5.5	14	12	6.5	8	6.25	7.5	27	M6	0.020	100
U746-10	TUBULAR LUG 25 ² -10	6.6	15	17	10.5	9.5	12	12	34	M10	0.020	100
U747-8	TUBULAR LUG 35 ² -8	7.9	17	17	8.5	11	10	10	34	M8	0.020	100
U747-10	TUBULAR LUG 35 ² -10	7.9	17	17	10.5	11	12	12	37	M10	0.021	100
U747-12	TUBULAR LUG 35 ² -12	7.9	17	17	13	11	13	13	38	M12	0.021	100
U748-8	TUBULAR LUG 50 ² -8	9.2	19	18	8.5	12.5	10	10	37	M8	0.029	100
U748-10	TUBULAR LUG 50 ² -10	9.2	19	18	10.5	12.5	12	12	40	M10	0.031	100
U748-12	TUBULAR LUG 50 ² -12	9.2	19	19	13	12.5	13	13	41	M12	0.032	100
U749-8	TUBULAR LUG 70 ² -8	11	21	21	8.5	15	10	10	41	M8	0.044	100
U749-10	TUBULAR LUG 70 ² -10	11	21	21	10.5	15	12	12	43	M10	0.045	100
U749-12	TUBULAR LUG 70 ² -12	11	21	21	13	15	13	13	46	M12	0.046	100
U750-8	TUBULAR LUG 95 ² -8	13.1	25	23	8.5	17	10	10	46	M8	0.054	50
U750-10	TUBULAR LUG 95 ² -10	13.1	25	23	10.5	17	12	12	48	M10	0.054	50
U750-12	TUBULAR LUG 95 ² -12	13.1	25	23	13	17	13	13	50	M12	0.056	50
U752-12	TUBULAR LUG 150 ² -12	16.2	26	30	13	21	15	15	58	M12	0.077	50
U752-14	TUBULAR LUG 150 ² -14	16.2	26	30	15	21	15	15	58	M14	0.076	50
U754-12	TUBULAR LUG 240 ² -12	20.6	35	39	13	26	21.5	19	72	M12	0.146	20
U754-14	TUBULAR LUG 240 ² -14	20.6	35	39	15	26	21.5	19	72	M14	0.142	20
U755-16	TUBULAR LUG 300 ² -16	23.1	44	41	17	28	19	20	83	M16	0.150	100

SEE SHEET
INSTALLATION / Hydraulic crimping tool

Spin-welded terminal lug for copper terminal

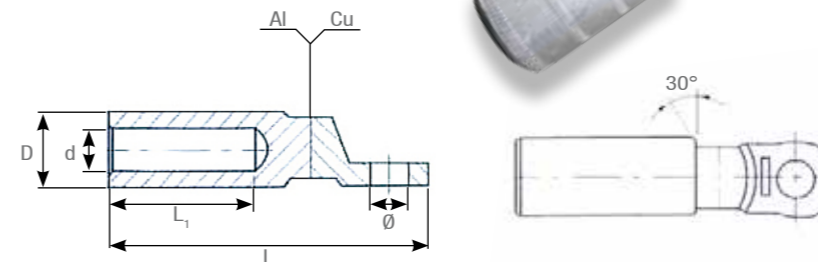

MIRELEC

Application

This friction welded lug is used to connect aluminium bare conductors to copper equipment terminals. This lug is implemented by crimping. This lug meets the requirement of the **NFC 33 090-1** standard.

Code	Designation	Dimensions (mm)					Weight (kg)	Sales unit
		Ø	D	d	L ₁	L		
F150	35mm ² BIMETAL SPIN-WELDED BARE TERMINAL LUG	10.5	16	8	30	69	0.050	3
F151	50mm ² BIMETAL SPIN-WELDED BARE TERMINAL LUG	10.5	16	9	30	69	0.070	3
F153	70mm ² BIMETAL SPIN-WELDED BARE TERMINAL LUG	10.5	20	11	30	69	0.080	3
F156	95mm ² BIMETAL SPIN-WELDED BARE TERMINAL LUG	10.5	20	12.5	30	69	0.090	3
F154	150mm ² BIMETAL SPIN-WELDED BARE TERMINAL LUG	12.8	27	15.5	36	81	0.110	3
F155	240mm ² BIMETAL SPIN-WELDED BARE TERMINAL LUG	12.8	27	19.5	36	90	0.150	3

Tinned aluminium lug

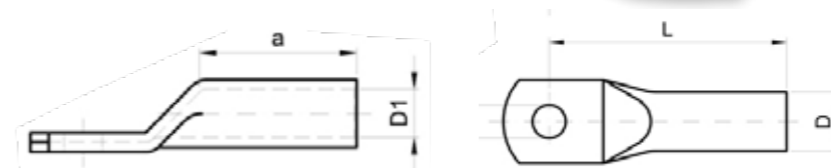

Application

This tinned aluminium lug is made of aluminium alloy of purity equal or higher than 99.5%. The complete cable lug surface is tinned by means of an electrolytic process. Some neutral grease is incorporated to avoid aluminium oxidation. This lug is implemented with hexagonal compressed connection. This lug meets the requirement of the **DIN EN 50182**.

Code	Designation	Section (mm ²)	Dimensions (mm)					Weight (kg)	Sales unit
			a	L	D	D1	D2		
U037-16	ALU LUG TINNED 16 ²	16	32	52	11	5.5	13	0.053	1
U037-25	ALU LUG TINNED 25 ²	25	38	60	12	6.8	13	0.052	1
U037-35	ALU LUG TINNED 35 ²	35	42	67	14	8	13	0.051	1
U037-50	ALU LUG TINNED 50 ²	50	45	72	16	9.6	13	0.050	1
U037-54.6	ALU LUG TINNED 54.6 ²	54.6	52	86	18	11.2	13	0.051	1
U037-70	ALU LUG TINNED 70 ²	70	52	86	18	11.2	17	0.046	1
U037-95	ALU LUG TINNED 95 ²	95	56	90	22	13	13	0.043	1
U037-120	ALU LUG TINNED 120 ²	120	58	91	22.5	15	13	0.092	1
U037-150	ALU LUG TINNED 150 ²	150	60	103	25	16.5	13	0.085	1
U037-185	ALU LUG TINNED 185 ²	185	62	106	28	18	17	0.150	1
U037-240	ALU LUG TINNED 240 ²	240	65	116	32	21	17	0.135	1
U037-300	ALU LUG TINNED 300 ²	300	70	124	34	23.3	17	0.315	1

Sealing end cap and cover

Sealing end cap



MICHAUD

Application

This flexible end cap is designed to ensure insulation of the end of a conductor. It can be used inside and outside.

Description

- The dielectric strength in water is greater than 6kV.
- The body is made of UV resistant black flexible synthetic material.

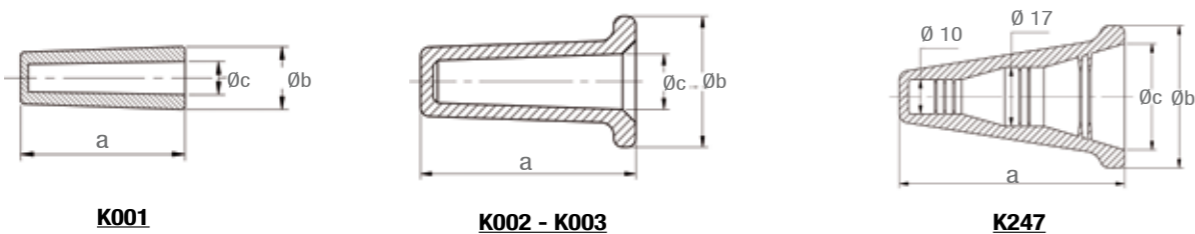

Dimensions in mm

Code	Designation	Dimensions (mm)			Capacities (mm ²)	Weight (kg)	Sales unit
		a	b	c			
K001	BLACK FLEXIBLE END CAP 10-50M	32	12	7	10-50M	0.003	20
K002	BLACK FLEXIBLE END CAP 35-95	40	16	10.5	35-95	0.008	20
K003	BLACK FLEXIBLE END CAP 95-150	50	19	13	95-150	0.012	20
K247	BLACK FLEXIBLE END CAP 95-240	67.2	45	31	Round: 50-240 Sectoral: 95-240	0.027	6

Sealing end cap and cover implementation on cable

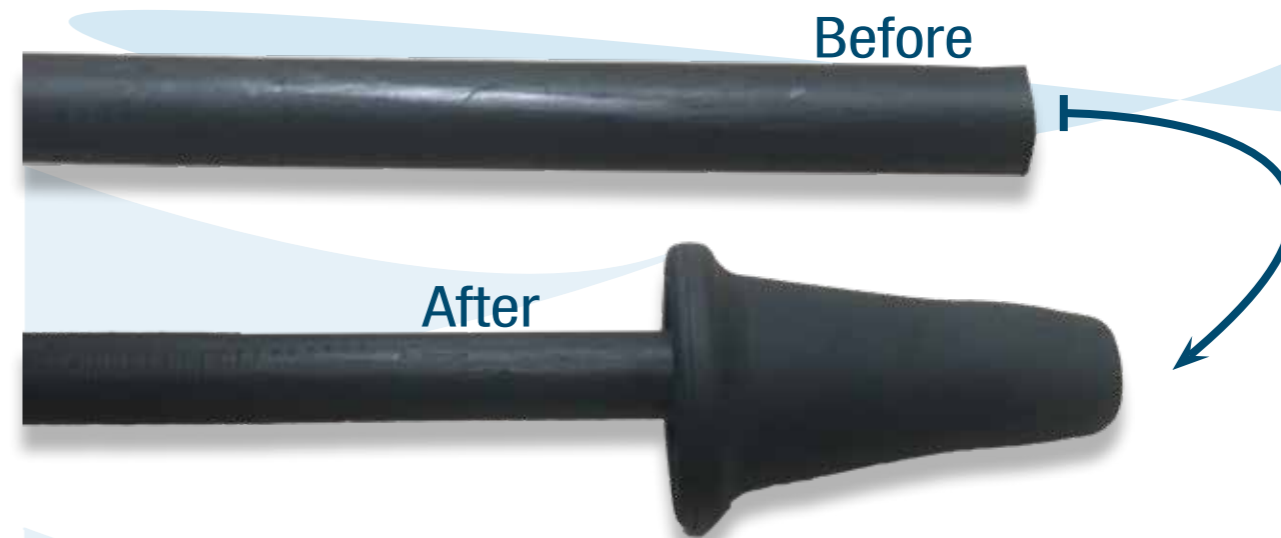

In our videos:

- + Installation steps
- + Tools required
- + Technical characteristics



All of our installation videos are on our Michaud Export Youtube channel.

Heat-shrinkable material

End cap



MIRELEC

Application

This heat-shrinkable material is designed for low voltage applications in order to protect conductors and make them watertight. It is characterised by its insulating performances and its high resistivity to pollution and UV. It is retracted by blow torch heating.

Description

- CRB and CRR caps are designed for conductors only.
- CRC caps are designed for cables with many conductors.

Code	Designation	Section (mm ²)	Use diameter (mm)	Weight (kg)	Sales unit
FOR CONDUCTORS ONLY					
F109	HEAT-SHRINKABLE END CAP CRB 1.5-10	1.5 to 10	3 to 6,5	0.003	100
F110	HEAT-SHRINKABLE END CAP CRB 10-25	10 to 25	6 to 9	0.004	50
F111	HEAT-SHRINKABLE END CAP CRR 16-70	16 to 70	9 to 12	0.006	50
F112	HEAT-SHRINKABLE END CAP CRR 150	150	18 to 23	0.024	10
F116	HEAT-SHRINKABLE END CAP CRR 240	240	23 to 28	0.038	10
FOR CABLES					
F113	HEAT-SHRINKABLE END CAP CRC 16-27		15 to 30	0.024	10
F114	HEAT-SHRINKABLE END CAP CRC 26-48		25 to 45	0.045	10
F115	HEAT-SHRINKABLE END CAP CRC 46-80		32 to 65	0.065	10

End

Description

This heat-shrinkable end is fitted at the end of a single phase or multi-phase junction.



MIRELEC

Code	Designation	Section (mm ²)	Number of conductors	Weight (kg)	Sales unit
F100	HEAT-SHRINKABLE END E2R 10-35	10 to 35	2	0.015	20
F101	HEAT-SHRINKABLE END E4R 10-35	10 to 35	4	0.035	20
F102	HEAT-SHRINKABLE END E4R 50-150	50 to 150	4	0.047	20
F103	HEAT-SHRINKABLE END E4R 240	240	4	0.095	5

Sheath

Description

This heat-shrinkable sheath is used when neutral and phases have to be insulated. It is delivered in 10m rolls.



Code	Designation	Diameter application (mm)	Section (mm ²)*	Weight (kg)	Sales unit
F120	HEAT-SHRINKABLE SHEATH GR 10-35 (10m)	4.5-7.5	1,5-10	0.200	1
F119	HEAT-SHRINKABLE SHEATH GR 35-95 (10m)	6-16	16-95	0.350	1
F121	HEAT-SHRINKABLE SHEATH GR 50-150 (10m)	9-26.5	25-150	0.500	1
F122	HEAT-SHRINKABLE SHEATH GR 240 (10m)	14.5-32	70-240	0.800	1

*The sections indicated correspond to NF standards. For other standards, please refer to the diameter of application.

Sleeve

Description

This heat-shrinkable sleeve is used when a bare sleeve has to be insulated.



Code	Designation	Use diameter (mm)	Section (mm ²)*	Length (mm)	Weight (kg)	Sales unit
F130	HEAT-SHRINKABLE SLEEVE FRM 16-100	7.5-17	25-120	100	0.100	10
F131	HEAT-SHRINKABLE SLEEVE FRM 25-100	10-25	35-150	100	0.100	10
F132	HEAT-SHRINKABLE SLEEVE FRM 25-200	10-25	35-150	200	0.200	10
F129	HEAT-SHRINKABLE SLEEVE FRM 30-150	10-25	35-150	150	0.250	10
F133	HEAT-SHRINKABLE SLEEVE FRM 30-250	10-25	35-150	200	0.300	10
F134	HEAT-SHRINKABLE SLEEVE FRM 30-200	10-26.5	35-185	250	0.350	10
F135	HEAT-SHRINKABLE SLEEVE FRM 35-150	15-30	95-240	150	0.250	10
F136	HEAT-SHRINKABLE SLEEVE FRM 35-250	15-30	95-240	250	0.400	10

*The sections indicated correspond to NF standards. For other standards, please refer to the diameter of application.

Stainless steel strap

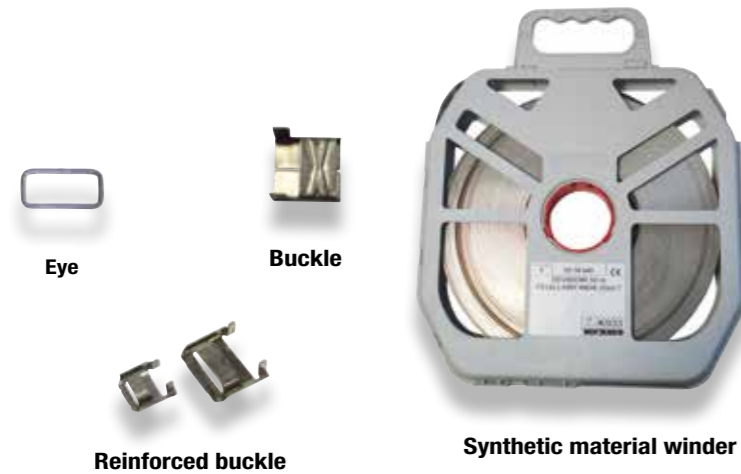

MICHAUD

Application

This stainless steel strap and this range of installation tools is designed to fix the suspension or anchoring clamp brackets on all types of poles (wooden, metal or concrete).

Description

- The strap is made of stainless steel AISI 201 or AISI 304.
- References of strap K930 et K935 are delivered in a roll inside an easy to handle synthetic material winder. References of strap K920 to K923 are delivered in a roll inside a cardboard winder.
- The strap edges are deburred.
- The elastomer protection tape for the strap prevents any cable injury if the cable fixed on poles with a strap falls. This strap meets the requirements of the **NF EN 10088-2**.

Code	Designation	Weight (kg)	Sales unit
K930	50m WINDER STAINLESS STEEL STRAP 10x0.4mm	1.850	5
K931	50m WINDER STAINLESS STEEL STRAP 10x0.7mm	2.950	5
K932	50m WINDER STAINLESS STEEL STRAP 20x0.4mm	3.450	5
K933	50m WINDER STAINLESS STEEL STRAP 20x0.7mm	5.800	5
K951	SET OF 100 BUCKLES FOR 20mm STRAP	0.610	1
K953	SET OF 100 BUCKLES FOR 20mm STRAP	0.900	1
K955	SET OF 100 REINFORCED BUCKLES FOR 20mm STRAP	1.000	1
K654	SET OF 100 EYES 25x25	1.660	1
K655	SET OF 100 EYES 25x40	2.160	1
K656	SET OF 100 EYES 25x60	2.820	1

Variant: Cardboard winder

For further information, consult us.

+ Other lengths and dimensions are available for stainless steel strap



Accessories

- The tools are made of non-corrosive steel.
- The carrying case with ergonomic inside trim is made of synthetic material. It includes a cutting tool, binding tool and buckles (to be ordered separately).

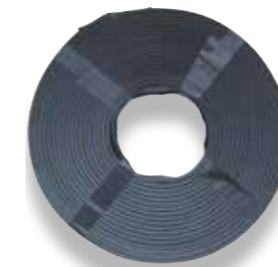

Protection tape



Folding plier



Binding tool ratchet type



Binding tool wheel type



Carrying case for strap tools



Cutting tool

Code	Designation	Weight (kg)	Sales unit
K957	PROTECTION TAPE FOR 10mm STRAP (10m length)	0.500	1
K958	PROTECTION TAPE FOR 20mm STRAP (10m length)	0.770	1
K959	BINDING TOOL WHEEL TYPE FOR STRAP	2.500	1
K960	BINDING TOOL RATCHET TYPE FOR STRAP	1.950	1
K961	CUTTING TOOL FOR STRAP	0.550	1
K963	CARRYING CASE FOR STRAP TOOLS	0.550	1
K968	STRAP FOLDING PLIER	0.510	1



Installation video available on www.michaud-export.com (tab Documentation > Installation videos)

Neutral messenger network suspension and anchoring

Anchoring assembly

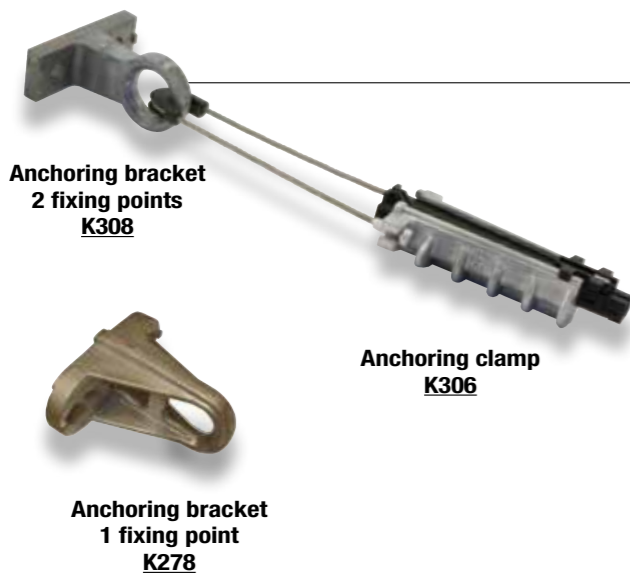

MICHAUD

Application

This anchoring assembly is designed for the 1500daN single or double anchoring of A.B.C. (Aerial Bundled Conductors) with insulated neutral messenger of 54.6 and 70mm² sections. It comprises a bracket supporting one or two anchoring clamps.

Description

Anchoring clamp:

- The body is made of aluminium alloy.
- The cleats are made of UV resistant synthetic material. They are captive.
- The stainless steel flexible linking cable is captive. It is equipped with a resistant, insulated and movable saddle.
- Fixing the insulated neutral messenger is ensured by cleats without damaging the insulation.

Anchoring bracket

- The bracket is made of aluminium alloy and permits single or double anchoring.
- Fixing on poles is ensured by one or two 14 or 16mm diameter bolts with suitable washers or using two 20x0.7mm stainless steel straps.

This anchoring assembly meets the criteria of the **NF C 33-041** and **EN 50-483** standards.

Installation

- Fix the bracket on the pole using one or two 14 or 16mm diameter bolts with suitable washers or using two 20x0.7mm stainless steel straps.
- Open the A.B.C. where the installation has to be done.
- Slide the cleats backward.
- Insert the neutral messenger between the cleats.
- Push the cleats in the clamp while keeping the neutral messenger in place.
- Anchor the clamp on the bracket.
- Additional tightening is achieved automatically by the cleats.

Code	Designation	Weight (kg)	Sales unit
K306	ANCHORING CLAMP - PA 1500	0.430	30
K278	ANCHORING BRACKET - CA 1500 - 1FP	0.320	30
K308	ANCHORING BRACKET - CA 1500 - 2FP	0.250	30

Suspension assembly



Suspension assembly
ES 1500 (50 - 95mm²): **K277**

Fuse suspension assembly ESF 715
(50 - 70mm²): **K283**

MICHAUD

Application

This suspension assembly is designed for suspending the low voltage A.B.C. (Aerial Bundled Conductors) with insulated neutral messenger of 50 - 95mm² sections for code K277 and 50 - 70mm² sections for code K283.

It comprises a movable link system, a suspension clamp and a bracket.

2 standard suspension assemblies are available:

- ES 1500,
- ESF 715 equipped with a fuse element (breaking 715 ± 65daN).

The fuse element can be factory calibrated between 500 and 1 200daN. It is designed to break when an abnormal effort is applied on the A.B.C. The cable drops without causing the pole to break (i.e.: tree falling on to a power line). The cable can be quickly put back in position thanks to the installation of a new clamp on the bracket still in place.

Description

The suspension clamp, the movable link system and the bracket are delivered in a full set.

Suspension clamp:

- The body is made of UV resistant, glass fibre reinforced synthetic material.
- The insulated neutral messenger is secured by the notched tightening lever.

Movable link system:

- The body is made of UV resistant, glass fibre reinforced synthetic material and adds insulation between the pole and the cables.
- The design facilitates longitudinal and transversal movement of the suspension clamp body.
- The ESF 715 incorporates the fuse element.

Bracket:

- The bracket is made of aluminium alloy.
- Fixing on poles is ensured by a 14 or 16mm diameter bolt with a suitable washer or using two 20x0.7mm stainless steel straps.

This suspension assembly meets the criteria of **NF C 33-040** and **EN 50-483**.

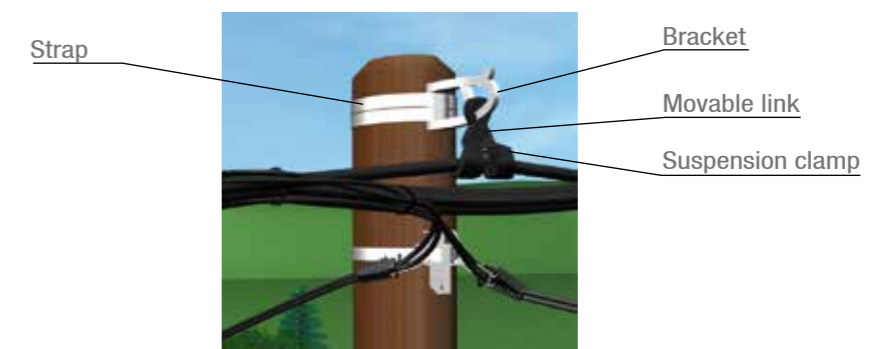

Code	Designation	Weight (kg)	Sales unit
K277	SUSPENSION ASSEMBLY [50-95] - ES 1500	0.550	20
K283	FUSE SUSPENSION ASSEMBLY [50-70] - ESF 715	0.438	25
K280	SPARE PART - PS + LM 715	0.210	1

- Notes:
- Contact us for any other breaking values for the fuse element.
 - Fixing with bolts and washers or stainless steel straps must be ordered separately.
 - The insulated tie must be ordered separately.

SEE SHEET
OVERHEAD / Mechanical fixing / Stainless steel strap

Fully supported network suspension and anchoring

Anchoring clamp



MICHAUD

Application

This clamp is designed to anchor the low voltage fully supported A.B.C. (Aerial Bundled Conductors).

Description

- The arms are made of hot-dip galvanised steel. A bolt enables the clamp to be easily dismantled manually and anchored on a bracket fixed to a pole or façade.
- The cleats are made of UV resistant, glass fibre reinforced synthetic material.
- The conductors are attached using a combination of bolts and cleats. Two 17mm shear head nuts are used to control the tightening torque.
- Each conductor runs through a separate channel. The conductors are anchored by distributing the loads, protecting the insulation.
- A large opening facilitates the passage of the conductors between the clamp arms.
- The mechanical resistance is 3300daN for the K288, and is greater than 5000daN for the K302.

This clamp meets the criteria of the **DIN VDE 0211** standard.

Installation

- Unscrew the nuts.
- Open the A.B.C and insert each conductor into one of the channels.
- Screw the nuts alternately using a 17mm spanner until the shear head breaks. The 21mm head is only provided for possible dismantling.
- Anchor the clamp on a hook.
- Additional tightening is achieved automatically by the cleats.

Code	Designation	Weight (kg)	Sales unit
K288	FULLY SUPPORTED ANCHORING CLAMP 4x50-95 *	1.240	10
K302	FULLY SUPPORTED ANCHORING CLAMP 4x120 *	1.620	20

* Products manufactured on request only. Please contact us.

SEE SHEET
INSTALLATION / LV insulated toolings

Movable suspension clamp



MICHAUD

Application

This clamp is designed to suspend the low voltage fully supported A.B.C. (Aerial Bundled Conductors). It is suitable for angles on poles up to 30°.

Description

- The body, the tightening screw and the washer are made of hot-dip galvanised steel.
- The shear head nut enables controlled tightening of the A.B.C.
- The fastener is captive during installation of the A.B.C. in the body.
- The insert made of UV resistant synthetic material ensures secure holding of the A.B.C.
- The fixing hole on the body is reinforced using an eye made of UV resistant synthetic material. It enables the assembly to be implemented on a pole or on a façade equipped with hook.

This clamp meets the criteria of the **DIN VDE 0211** standard.

Installation

- Unscrew the tightening screw.
- Remove the screw and take out the insert made of synthetic material.
- Place the body of the suspension clamp on a hook.
- Put the A.B.C. in the insert.
- Put the insert back in the body of the suspension clamp.
- Replace the screw then screw the nut using a 13mm spanner until the shear head breaks (7Nm).

Code	Designation	Weight (kg)	Sales unit
K267	FULLY SUPPORTED SUSPENSION CLAMP MOVABLE 2x16-2x25 *	0.550	30
K270	FULLY SUPPORTED SUSPENSION CLAMP MOVABLE 4x16-4x25 *	0.540	30
K274	FULLY SUPPORTED SUSPENSION CLAMP MOVABLE 4x35-4x50 *	0.530	30
K275	FULLY SUPPORTED SUSPENSION CLAMP MOVABLE 4x70 *	0.520	30
K276	FULLY SUPPORTED SUSPENSION CLAMP MOVABLE 4x95 *	0.510	30
K271	FULLY SUPPORTED SUSPENSION CLAMP MOVABLE 4x120 *	0.510	1

* Products manufactured on request only. Please contact us.

Option: Double suspension bracket

This accessory is designed for angle poles where the line deviation exceeds 30°.

It includes:

- 2 hooks to hold 2 suspension clamps,
- 1 ring to allow fixing on pigtail bolt or anchoring bracket.

The body is made of hot-dip galvanised steel.

Code	Designation	Dimensions (mm)			Maximum load daN (± 10%)	Weight (kg)	Sales unit
		a	b	c			
F220	DOUBLE SUSPENSION CLAMP BRACKET 12kN	16	106	174	1200	0.990	10

Service cable anchoring

Service anchoring assembly EA 25



MICHAUD

Application

This anchoring assembly is designed for fixing low voltage service A.B.C. (Aerial Bundled Conductors) with capacity of 2x6 to 4x25mm². The anchoring clamp is also available in an adjustable hook version.

Description

Anchoring clamp:

- The body is made of UV resistant, glass fibre reinforced synthetic material.
- The wedge is made of UV resistant synthetic material. 4 channels ensure the clamping of 2 or 4 conductors by distributing the loads, protecting the insulation. It is connected to the handle via its integrated link.
- The handle and the hook have good corrosion resistance: stainless steel for K307 and galvanized steel for K309 and L311.
- The hook can be adjusted once positioned (toothed rack with 10cm stroke).
- All of the elements are captive.
- The tensile strength is 200daN.

Fixing clamp and bracket:

- These elements are made of aluminium alloy.
- The fixing clamp is designed for single anchoring whereas the bracket offers up to 6 fixing points.
- Their specific design allows fixing on wooden, metal or concrete poles.
- The fixing clamp is implemented using a 10mm diameter bolt or using a 20x0.7mm stainless steel strap (tensile strength: 200daN).
- The fixing bracket is implemented using a 14 or 16mm diameter bolt or using two 20x0.7mm stainless steel straps (tensile strength: 200daN/anchoring point).

This anchoring assembly meets the criteria of the **NF C 33-042** and **EN 50-483** standards.

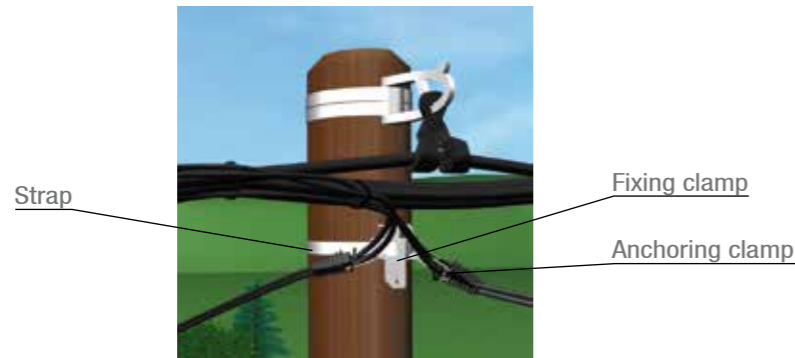

Code	Designation	Weight (kg)	Sales unit
L304	FIXING CLAMP - PF 25	0.010	100
L306	SCREW - M10	0.050	50
K307	ANCHORING CLAMP WITH HANDLE - PA 25	0.105	50
L311	SERVICE ANCHORING CLAMP GS - PA 25	0.105	50
K309	ANCHORING CLAMP WITH ADJUSTABLE HOOK - PACR 25	0.230	1
F305	MULTIPLE ANCHORING BRACKET - CAM 25	0.220	100

Note: fixing with bolts or a stainless steel strap must be ordered separately.

Service anchoring assembly PA 35



MICHAUD

Application

This anchoring clamp is designed for fixing or suspending low voltage service A.B.C. (Aerial Bundled Conductors) with capacity of 3x16 to 4x35mm².

Description

- The blocks are made of UV resistant, glass fibre reinforced synthetic material. They are held open via the use of springs.
- The conductors are attached using a combination of blocks and a bolt. The 17mm shear head nut is used to control the tightening torque.
- Each conductor runs through a separate channel. 3 or 4 conductors are anchored by distributing the load, protecting the insulation.
- The arm is made of hot-dip galvanised steel. A large hole at the end allows anchoring of the clamp on a bracket or a hook fixed on a pole or façade. The arm offers an opening through an oblong hole (on request, a hook type opening is available).
- The tensile strength on fully supported A.B.C. is 500daN (version with oblong arm).

The benefit:

+ Rotative blocks for two functions



Installation

Fixing:

- Unscrew the nut without removing it. The blocks are held opened using springs.
- Open the A.B.C and insert each conductor into one of the channels.
Comment: Remove the rod and its adhesive for a 4 conductors bundle.
- Anchor the end of the clamp on a bracket or a hook.
- Screw the nut using a 17mm spanner until the shear head breaks to ensure fixing of the conductors. The 21mm permanent head is only provided for possible dismantling.

Code	Designation	Weight (kg)	Sales unit
K300	SERVICE CABLE CLAMP 3/4 x 16-35 TYPE CLOSED EYE - PA 35	0.480	10

Variant: Clamp with hook arm

The 3/4x16-35 service cable clamp (K300) can be supplied with a hook arm.



Code	Designation	Weight (kg)	Sales unit
K301	SERVICE CABLE CLAMP 3/4 x 16-35 TYPE HOOK - PA 35	0.480	10

SEE SHEET
INSTALLATION / LV insulated toolings

Low voltage line accessory

Anchoring and suspension clamp

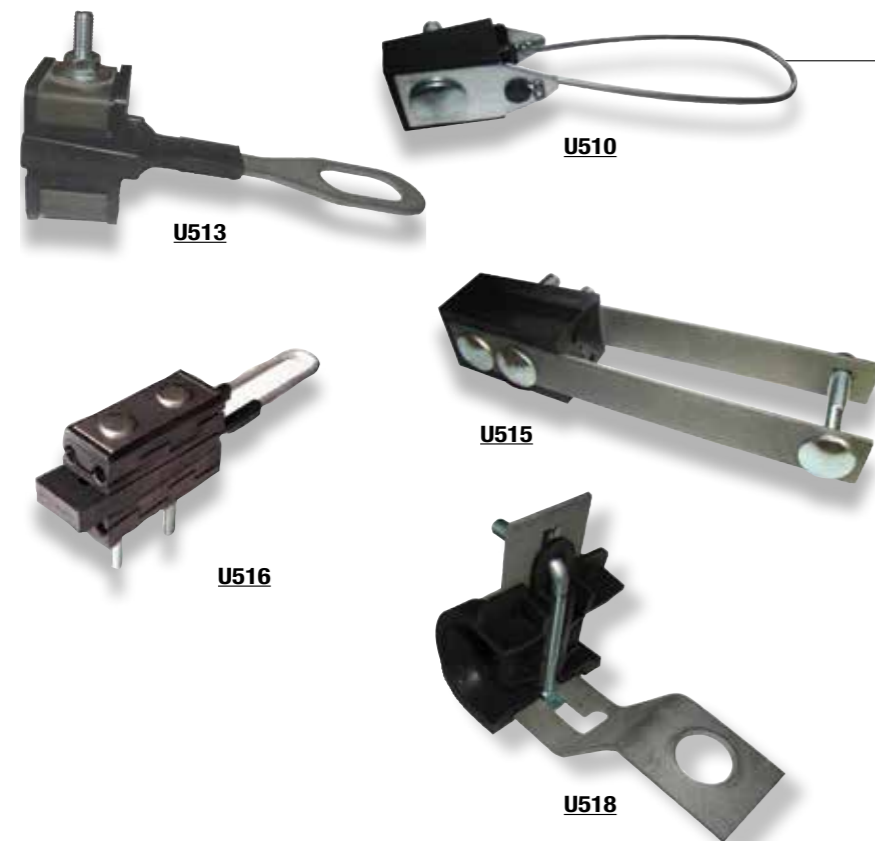

MIRELEC

Application

These anchoring and suspension clamps are designed to anchor and to hold the A.B.C. (Aerial Bundled Conductors) network.

This range is rather designed to self-supporting cable.

Description

- These clamps can be used to fix and hold from 2 up to 4 insulated conductors between a pole and a wall or between two poles.
- Admitted conductors capacities go from 16 up to 120mm².
- Clamps body is made of polymer and the metallic parts are made of hot dip galvanised steel.

Code	Designation	Mechanical resistance (daN)	Section (mm ²)	Weight (kg)	Sales unit
ANCHORING CLAMP					
U510	ANCHORING CLAMP WITH MOVABLE HANDLE (NUT) 2x10-25	500	2 x 10-25	0.100	30
U511	ANCHORING CLAMP WITH MOVABLE HANDLE (NUT) 4x10-25	700	4 x 10-25	0.105	30
U512	ANCHORING CLAMP WITH CLOSED HANDLE 2x16-35	500	2 x 16-35	0.100	50
U513	ANCHORING CLAMP WITH CLOSED HANDLE 4x16-35	1 000	4 x 16-35	0.140	50
U514	FULLY SUPPORTED ANCHORING CLAMP OPENED HANDLE 4x25-50 EC	2 500	4 x 25-50	0.490	5
U515	FULLY SUPPORTED ANCHORING CLAMP OPENED HANDLE 4x50-95 EC	3 500	4 x 50-95	0.880	30
U516	FULLY SUPPORTED ANCHORING CLAMP CLOSED HANDLE 4x35-70 EC	2 500	4 x 35-70	0.850	30
U517	FULLY SUPPORTED ANCHORING CLAMP CLOSED HANDLE 4x70-120 EC	4 000	4 x 70-120	1.215	30
SUSPENSION CLAMP					
U518	FULLY SUPPORTED SUSPENSION CLAMP 4x10-120	2 500	4 x 10-120	0.343	20

Suspension bracket

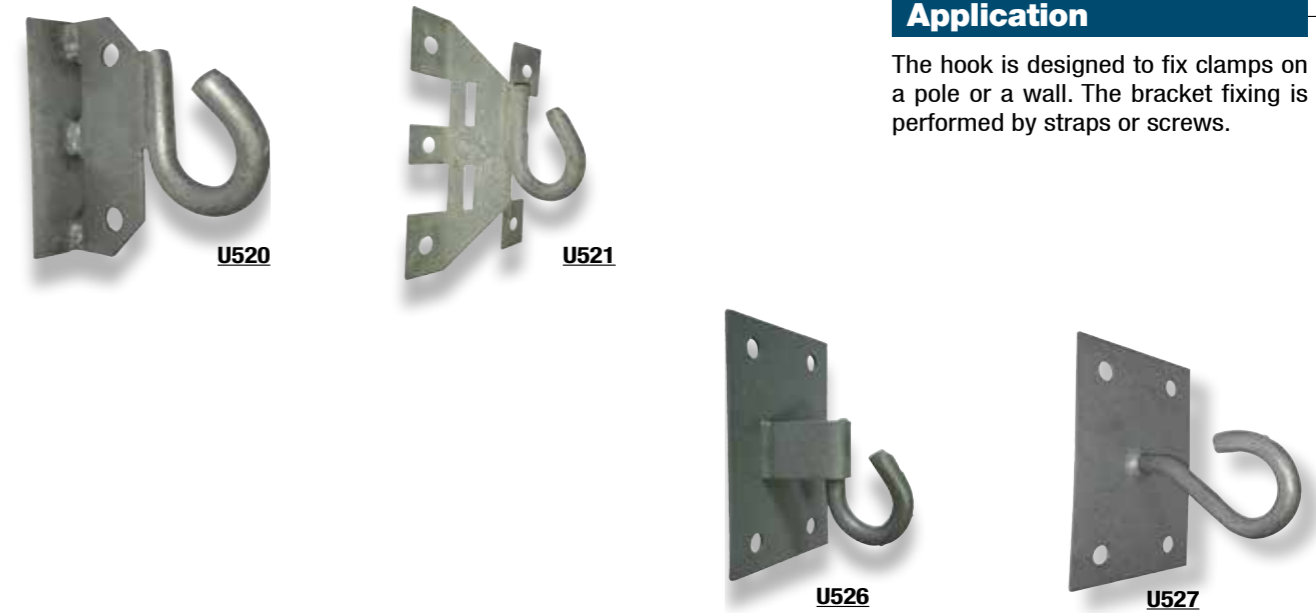

MIRELEC

Application

The hook is designed to fix clamps on a pole or a wall. The bracket fixing is performed by straps or screws.

Code	Designation	Mechanical resistance (daN)	Section (mm ²)	Weight (kg)	Sales unit
U520	BRACKET WITH HOOK DIAM 16 6 POLE TYPE	1 800	16	0.380	10
U521	BRACKET WITH HOOK DIAM 16 6 UNIVERSAL	1 800	16	0.330	10
U526	BRACKET WITH SUSPENSION HOOK DIAM 16 -1800 daN	1 800	16	0.570	10
U527	BRACKET WITH SUSPENSION HOOK DIAM 16 -2000 daN	2 000	16	0.440	10

Hook



Application

The hook is used to fix an anchoring clamp on a pole or a wall. It is implemented once holes are drilled.

Code	Designation	Length (mm)	Section (mm ²)	Weight (kg)	Sales unit
U522	HOOK BOLT DIAM 16 -250	250	16	1.080	10
U523	HOOK BOLT DIAM 20 -250	250	20	1.175	10
U524	HOOK NUT DIAM 16	200	16	0.350	10
U525	HOOK NUT DIAM 20	200	20	0.360	10

Cable saddle

Facade fixing

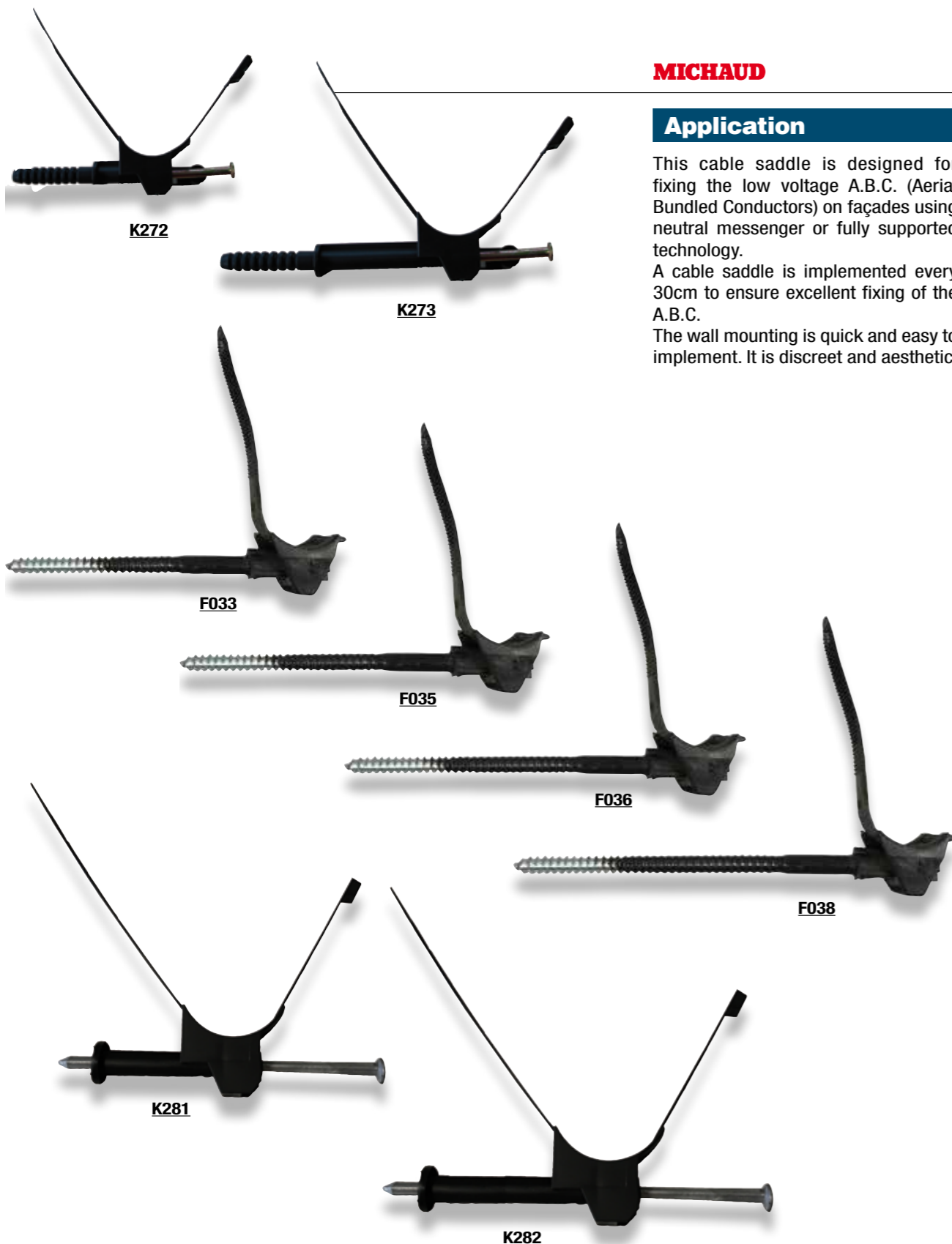

MICHAUD

Application

This cable saddle is designed for fixing the low voltage A.B.C. (Aerial Bundled Conductors) on façades using neutral messenger or fully supported technology. A cable saddle is implemented every 30cm to ensure excellent fixing of the A.B.C. The wall mounting is quick and easy to implement. It is discreet and aesthetic.

Description

- Three types of cable saddles are available:
 - **BRPF**: cable saddle to be fixed on façades by a nail (12mm Ø hole).
 - **BRPV**: cable saddle to be fixed on façades by a screw and dowel pin (12mm Ø hole).
 - **BRTV**: cable saddle to be fixed on façades by a reinforced screw and dowel pin assembly (16mm Ø hole).
- The body and cable tie are made of UV resistant synthetic material.
- The opening under the saddle allows the use of an extra tie (not provided) to install a second conductor.
- The cable tie has outside teeth for:
 - Excellent protection of conductor insulation,
 - Excellent fixing of service and network conductors.

This cable saddle meets the criteria of the **NF C 33-040** and **EN 50-483** standards

Code	Designation	A.B.C. capacity (mm ²)	Wall clearance (mm)	Weight (kg)	Sales unit
K272	CABLE SADDLE - BRPF1	2x16 to 4x35	10	0.040	100
K273	CABLE SADDLE - BRPF6	4x35 to 3x150 + 95N+16	60	0.060	100
F033	CABLE SADDLE - BRPV1	3x25+54.6N+16 to 3x150+95N+16	10	0.070	50
F035	CABLE SADDLE - BRPV6		60	0.080	50
F036	CABLE SADDLE - BRTV10		100	0.175	20
F038	CABLE SADDLE - BRTV17		170	0.240	20
K281	CABLE SADDLE - BRPF4	3x25 + 54.6N to	90	0.050	30
K282	CABLE SADDLE - BRPF9	3x150 + 95N + 16	40	0.065	25

Pole fixing



Application

This saddle is used to fix cable trunking on poles. It is fixed using a strap. It is made of UV protected thermoplastic material. The N733 is sealed with a cable tie for 15 to 30mm diameter cables, the N734 for 30 to 50mm diameter cables, and the N735 for 50 to 90mm cables.

Code	Designation	Weight (kg)	Sales unit
F043	CABLE SADDLE BIC 15/30 WITHOUT CABLE TIE	0.010	100
N733	CABLE SADDLE BIC 15/30	0.015	100
N734	CABLE SADDLE BIC 30/50	0.070	100
N735	CABLE SADDLE BIC 50/90	0.110	100

Cable tie

Synthetic material

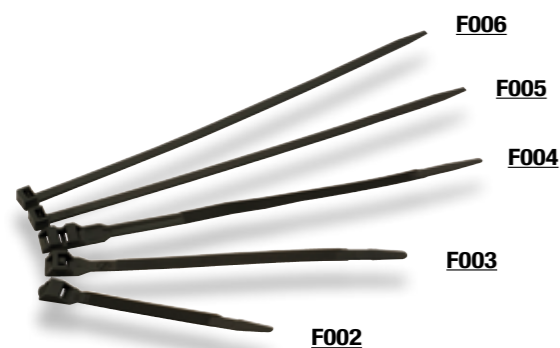

MICHAUD

Application

This cable tie made of black synthetic material is designed to tighten the phase and neutral conductors in order to achieve correct installation. It is used to prevent the conductors from rubbing against accessories such as clamps.

Description

- The cable tie is made of black UV resistant synthetic material.
- The strap has outside teeth for a 9mm width to secure fixing.
- The black UV resistant synthetic material cable tie mounts strap support are suitable for 9mm wide cable ties.
- The knock in wall cable tie mount has a drill hole diameter of 8mm.

Code	Designation	Diameter grip capacity		Weight (kg)	Sales unit
		MAX (mm)	MIN (mm)		
F001	CABLE TIE 9x123mm (100 pieces)	40	7	0.220	1
F002	CABLE TIE 9x180mm (100 pieces)	44	10	0.330	1
F003	CABLE TIE 9x265mm (100 pieces)	62	26	0.510	1
F004	CABLE TIE 9x360mm (100 pieces)	92	26	0.625	1
F005	CABLE TIE 9x500mm (100 pieces)	140	74	1.070	1
F006	CABLE TIE 9x750mm (100 pieces)	220	74	1.480	1
F013	IMPLEMENTATION TOOL FOR TIE			0.330	1
F040	WALL TYPE STRAP SUPPORT WITH BRACKET TO STRIKE (box of 100)			0.400	1
F041	WALL TYPE STRAP SUPPORT ATTACHED BY SCREW (box of 100)			0.300	1

Other dimensions are available. Please contact us.

Stainless steel



U705-350

MIRELEC

Application

This cable tie provides a self locking system enabling easy installation. It is made of stainless steel type 304. It is designed to allow installation in every type of environment.

Code	Designation	Width (mm)	Length (mm)	Max-bundle-diameter (mm)	Tensile strength (N)	Weight for 100 pieces (kg)	Sales unit		
U704-150	STAINLESS STEEL TIE 4.6x150	4.6	150	37	600	0.260	100		
U704-200	STAINLESS STEEL TIE 4.6x200		200	50		0.300	100		
U704-250	STAINLESS STEEL TIE 4.6x250		250	63		0.340	100		
U704-300	STAINLESS STEEL TIE 4.6x300		300	76		0.390	100		
U704-350	STAINLESS STEEL TIE 4.6x350		350	89		0.440	100		
U704-400	STAINLESS STEEL TIE 4.6x400		400	102		0.490	100		
U704-450	STAINLESS STEEL TIE 4.6x450		450	115		0.540	100		
U704-500	STAINLESS STEEL TIE 4.6x500		500	122		0.590	100		
U704-550	STAINLESS STEEL TIE 4.6x550		550	141		0.640	100		
U704-600	STAINLESS STEEL TIE 4.6x600		600	154		0.690	100		
U705-150	STAINLESS STEEL TIE 7.9x150		7.9	150		37	800	0.440	100
U705-200	STAINLESS STEEL TIE 7.9x200			200		50		0.500	100
U705-250	STAINLESS STEEL TIE 7.9x250	250		63	0.560	100			
U705-300	STAINLESS STEEL TIE 7.9x300	300		76	0.630	100			
U705-350	STAINLESS STEEL TIE 7.9x350	350		89	0.700	100			
U705-400	STAINLESS STEEL TIE 7.9x400	400		102	0.780	100			
U705-450	STAINLESS STEEL TIE 7.9x450	450		115	0.860	100			
U705-500	STAINLESS STEEL TIE 7.9x500	500		128	0.920	100			
U705-550	STAINLESS STEEL TIE 7.9x550	550		141	1.000	100			
U705-600	STAINLESS STEEL TIE 7.9x600	600		154	1.080	100			
U705-650	STAINLESS STEEL TIE 7.9x650	650		167	1.170	100			
U705-700	STAINLESS STEEL TIE 7.9x700	700		180	1.260	100			
U705-750	STAINLESS STEEL TIE 7.9x750	750		191	1.350	100			
U705-800	STAINLESS STEEL TIE 7.9x800	800		193	1.440	100			

Pigtail bolt



F345



Pigtail bolt (BQC)

MIRELEC

Application

This material made of hot dip galvanised steel is designed to fix anchoring and suspension clamps.

Installation

The anchoring clamp is fixed on the pole thanks to the pigtail bolt.

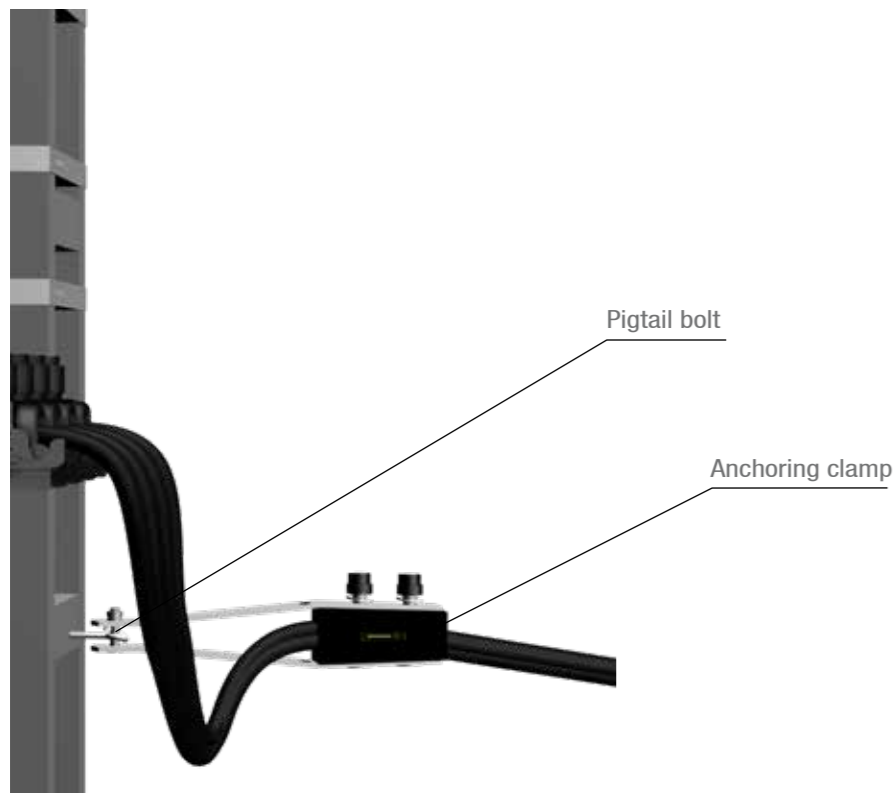

Code	Designation	Weight (kg)	Sales unit
WITH 1 NUT			
F312	PIGTAIL BOLT BQC 12x55 WITH 1 NUT	0.180	10
F314	PIGTAIL BOLT BQC 12x110 CH WITH 1 NUT *	0.300	10
WITH 1 WELDED WASHER AND 1 NUT			
U479_12-250	PIGTAIL BOLT BQC 12x250 WITH 1 WELDED WASHER AND 1 NUT	0.300	10
U479_12-300	PIGTAIL BOLT BQC 12x300 WITH 1 WELDED WASHER AND 1 NUT	0.340	10
U479_14-250	PIGTAIL BOLT BQC 14x250 WITH 1 WELDED WASHER AND 1 NUT	0.360	10
U479_14-300	PIGTAIL BOLT BQC 14x300 WITH 1 WELDED WASHER AND 1 NUT	0.400	10
U479_16-300	PIGTAIL BOLT BQC 16x300 WITH 1 WELDED WASHER AND 1 NUT	0.500	10
WITH 2 NUTS			
F311	PIGTAIL BOLT BQC 12x150 WITH 2 NUTS	0.230	10
F313	PIGTAIL BOLT BQC 12x90 WITH 2 NUTS	0.240	10
F315	PIGTAIL BOLT BQC 12x250 WITH 2 NUTS	0.300	25
F316	PIGTAIL BOLT BQC 12x300 WITH 2 NUTS	0.340	25
F317	PIGTAIL BOLT BQC 12x350 WITH 2 NUTS	0.370	25
F322	PIGTAIL BOLT BQC 16x250 WITH 2 NUTS	0.450	10
F323	PIGTAIL BOLT BQC 16x300 WITH 2 NUTS	0.500	10
F319	PIGTAIL BOLT BQC 20x100 WITH 2 NUTS	0.400	10
F318	PIGTAIL BOLT BQC 20x240 WITH 2 NUTS	0.680	10
F321	PIGTAIL BOLT BQC 20x250 WITH 2 NUTS	0.700	10
F326	PIGTAIL BOLT BQC 20x400 WITH 2 NUTS	1.290	10
ACCESSORIES			
F330	NUT E12	0.020	10
F331	WASHER MG12	0.010	10
F345	ANCHORING HOOK PIGTAIL TQC 12x200	0.310	10

* Delivered with peg

Hot dip galvanised bolt and nut

Bolt and nut



MIRELEC

Application

These bolts and nuts are designed to fix MV/LV accessories.

Description

- This bolt and nut is made of hot dip galvanized steel class 8.8 for widths lower than 100mm and class 6.8 above.
- These bolts and nuts meet the criteria of the standards hereafter:
 - ISO 4014/4016/4017 - NF EN 24015
 - DIN 931/933
 - Nut ISO 4032 / DIN 834

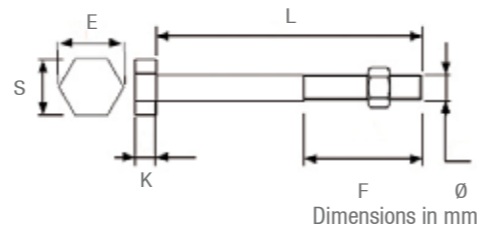

Dimensions in mm

Code	Designation	Ø	L	S	E	K	F	Weight (kg)	Sales unit
U435 8-30	BOLTS BH 8.30 (200 pieces)	8	30	12.73	14.38	5.15	30	4.5	1
U435 10-20	BOLTS BH 10.20 (100 pieces)	10	20	15.73	17.77	6.22	30	3.3	1
U435 10-30	BOLTS BH 10.30 (100 pieces)	10	30	15.73	17.77	6.22	30	3.6	1
U435 12-30	BOLTS BH 12.30 (200 pieces)	12	30	17.73	20.03	7.32	30	7.5	1
U435 12-50	BOLTS BH 12.50 (100 pieces)	12	50	17.73	20.03	7.32	50	5.5	1
U435 12-100	BOLTS BH 12.100 (100 pieces)	12	100	17.73	20.03	7.32	30	11	1
U435 12-150	BOLTS BH 12.150 (100 pieces)	12	150	17.73	20.03	7.32	36	14.2	1
U435 12-200	BOLTS BH 12.200 (100 pieces)	12	200	17.73	20.03	7.32	36	17.7	1
U435 12-250	BOLTS BH 12.250 (100 pieces)	12	250	17.73	20.03	7.32	49	21.2	1
U435 12-300	BOLTS BH 12.300 (100 pieces)	12	300	17.73	20.03	7.32	49	24.8	1
U435 14-30	BOLTS BH 14.30 (100 pieces)	14	30	20.67	23.36	8.62	30	5.4	1
U435 14-40	BOLTS BH 14.40 (100 pieces)	14	40	20.67	23.36	8.62	40	6.6	1
U435 14-50	BOLTS BH 14.50 (100 pieces)	14	50	20.67	23.36	8.62	50	7.8	1
U435 14-100	BOLTS BH 14.100 (100 pieces)	14	100	20.67	23.36	8.62	34	7.8	1
U435 14-150	BOLTS BH 14.150 (100 pieces)	14	150	20.67	23.36	8.62	40	21.6	1
U435 14-200	BOLTS BH 14.200 (100 pieces)	14	200	20.67	23.36	8.62	40	27.5	1
U435 14-250	BOLTS BH 14.250 (100 pieces)	14	250	20.67	23.36	8.62	53	30	1
U435 14-300	BOLTS BH 14.300 (100 pieces)	14	300	20.67	23.36	8.62	53	30	1
U435 14-350	BOLTS BH 14.350 (100 pieces)	14	350	20.67	23.36	8.62	53	39	1
U435 14-400	BOLTS BH 14.400 (100 pieces)	14	400	20.67	23.36	8.62	53	45	1
U435 14-450	BOLTS BH 14.450 (100 pieces)	14	450	20.67	23.36	8.62	53	50	1
U435 14-500	BOLTS BH 14.500 (100 pieces)	14	500	20.67	23.36	8.62	53	55	1
U435 14-600	BOLTS BH 14.600 (100 pieces)	14	600	20.67	23.36	8.62	53	75	1
U435 16-200	BOLTS BH 16.200 (100 pieces)	16	200	23.10	26.17	9.71	44	36	1
U435 16-250	BOLTS BH 16.250 (100 pieces)	16	250	23.10	26.17	9.71	57	43.4	1
U435 16-300	BOLTS BH 16.300 (100 pieces)	16	300	23.10	26.17	9.71	57	51	1
U435 16-350	BOLTS BH 16.350 (100 pieces)	16	350	23.10	26.17	9.71	57	58.5	1
U435 16-400	BOLTS BH 16.400 (100 pieces)	16	400	23.10	26.17	9.71	57	66	1
U435 20-100	BOLTS BH 20.100 (100 pieces)	20	100	29.16	32.95	12.15	46	36.5	1
U435 20-140	BOLTS BH 20.140 (100 pieces)	20	140	29.16	32.95	12.15	52	45.7	1
U435 20-160	BOLTS BH 20.160 (100 pieces)	20	160	29.16	32.95	12.15	52	50.6	1

Flat washer

The reference standard is **NF E 25513**.

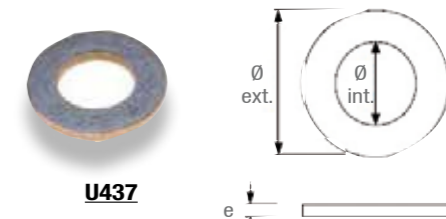

U437

Code	Designation	Ø external (mm)	Ø internal (mm)	e	Weight (kg)	Sales unit
U437 M8	WASHERS M8 (100 pieces)	18	8	1.50	0.22	1
U437 M10	WASHERS M10 (100 pieces)	22	11	2.00	0.44	1
U437 L10	WASHERS L10 (100 pieces)	26	11	1.50	0.8	1
U437 M12	WASHERS M12 (100 pieces)	27	14	2.50	0.82	1
U437 L12	WASHERS L12 (100 pieces)	32	14	2.50	1.3	1
U437 M14	WASHERS M14 (100 pieces)	30	16	2.50	1	1
U437 L14	WASHERS L14 (100 pieces)	36	16	2.50	1.6	1
U437 M16	WASHERS M16 (100 pieces)	32	18	3.00	1.5	1
U437 L16	WASHERS L16 (100 pieces)	40	18	3.00	2.3	1
U437 M20	WASHERS M20 (100 pieces)	40	22	3.00	2.4	1

M and L designations are series standards.

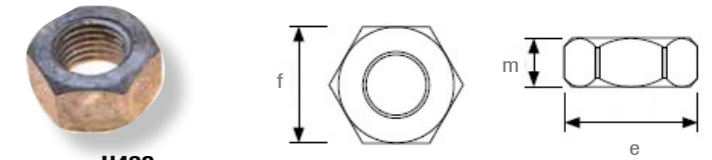

U438

The reference standard is **ISO 4032**.

Code	Designation	f (mm)	m (mm)	e (mm)	Weight (kg)	Sales unit
U438 HM8	NUTS HM8 (100 pieces)	13	6.80	14.38	1.1	1
U438 HM10	NUTS HM10 (100 pieces)	16	8.40	17.77	1.4	1
U438 HM12	NUTS HM12 (100 pieces)	18	10.80	20.03	1.7	1
U438 HM14	NUTS HM14 (100 pieces)	21	12.80	23.35	2	1
U438 HM16	NUTS HM16 (100 pieces)	24	14.80	26.75	3.4	1
U438 HM20	NUTS HM20 (100 pieces)	30	18.00	32.95	6.4	1

Threaded shaft

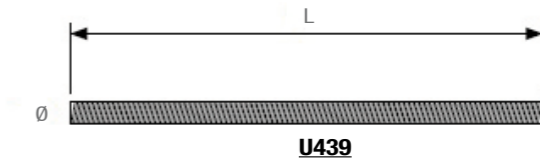

U439

Code	Designation	L (mm)	Ø (mm)	Weight (kg)	Sales unit
U439 12-1000	THREADED SHAFTS TF 12x1000 (100 pieces)	1000	12	70	1
U439 14-1000	THREADED SHAFTS TF 14x1000 (100 pieces)	1000	14	100	1
U439 16-1000	THREADED SHAFTS TF 16x1000 (100 pieces)	1000	16	140	1
U439 20-1000	THREADED SHAFTS TF 20x1000 (100 pieces)	1000	20	200	1

Screw

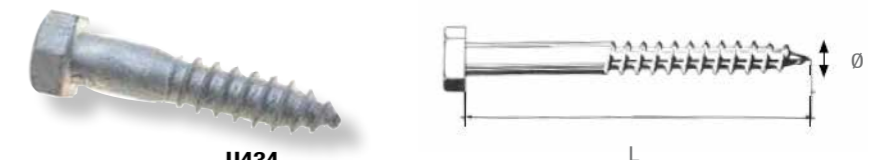

U434

The reference standard is **Din 571**.

Code	Designation	Ø (mm)	L (mm)	Weight (kg)	Sales unit
U434	GALVANISED LAG SCREW DIN 571 DIAMETER x LENGTH	6 up to 14	40 up to 200	Contact us	100

To discover the complete range, contact us. The code will take the next form U434-DIAM-L.

Protection accessory

Corrugated tube



MICHAUD

Application

This corrugated tube is designed to protect and insulate electrical cables and wires.

Description

- This tube is made of polyolefins.
- It is available in black or/and grey.
- It offers the following characteristics:
 - Scratch resistance: 320N,
 - Shock resistance: 2J.
- Minimum and maximum temperatures for use and installation are between -5°C and +60°C.
- Dielectric strength is 2 000V - 50Hz for 15min.
- Insulation resistance is $\leq 100M\Omega$ under 500V dc.
- Degree of protection is IP44 with accessories.
- It is delivered with wire-pulling.
- It is recommended to protect tubes from solar radiations.

Code	Designation	External diameter (in mm)	Minimal internal diameter (in mm)	Bending radius (in mm)	Weight (kg)	Sales unit
F140	RINGED TUBE DIAMETER 16 (100m)	16	10.7	48	4.80	1
F141	RINGED TUBE DIAMETER 20 (100m)	20	14.1	60	4.63	1
F142	RINGED TUBE DIAMETER 25 (50m)	25	18.3	75	7.00	1
F143	RINGED TUBE DIAMETER 32 (50m)	32	24.3	96	4.60	1
F144	RINGED TUBE DIAMETER 40 (50m)	40	31.2	160	3.00	1
F145	RINGED TUBE DIAMETER 50 (50m)	50	39	300	6.00	1
F146	RINGED TUBE DIAMETER 63 (50m)	63	47	378	7.00	1
F148	RINGED TUBE DIAMETER 90 (50m)	90	67	540	11.1	1
F149	RINGED TUBE DIAMETER 110 (50m)	110	82	660	16.6	1
F012	TIE FOR IRO TUBE WITH BASE 16-32 (set of 100)				0.35	1

Protective duct for aerial-subsurface connection

Metal

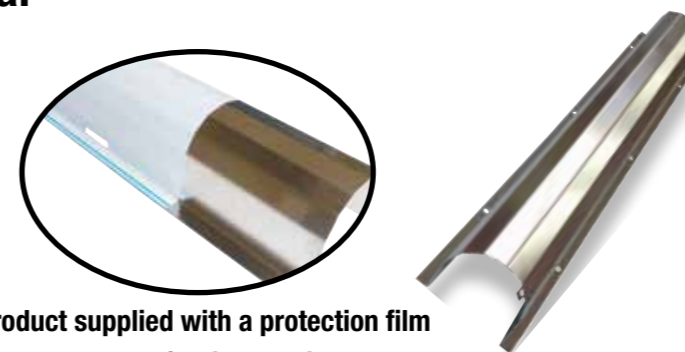

MICHAUD

Application

This protective duct is designed to protect aerial-subsurface connections on poles or façades. It is fixed on pole using straps or on facade using screws. It offers an IK10 degree of protection. It is made of metal (aluminium).

+ Product supplied with a protection film to be removed after installation

	Code	Designation	Length (m)	Weight (kg)	Sales unit
	N297	METAL PROTECTIVE DUCT GPC 35.35mm	2.75	1.100	5
	N298	METAL PROTECTIVE DUCT GPC 60.60mm	2.75	1.700	5
	N299	METAL PROTECTIVE DUCT GPC 90.90mm	2.75	2.350	1
	N300	METAL PROTECTIVE DUCT GPC 120.120mm	2.75	2.950	1

Synthetic material



MICHAUD

Application

This PVC duct is designed to protect aerial-subsurface connections on poles or façades. It is fixed on pole using straps or on façade using screws.

	Code	Désignation	Use	Length (m)	Weight (kg)	Sales unit
	N273	PROTECTIVE DUCT GPT 30.30 GREY	Earth wire	2.60	0.550	10
	N274	PROTECTIVE DUCT GPC 35.35 GREY	LV 4x50 maxi	2.75	1.010	10
	N275	PROTECTIVE DUCT GPC 60.60 GREY	LV 3x240 + 95 maxi	2.75	1.960	10
	N276	PROTECTIVE DUCT GPC 90.90 GREY	MV 3x150 + 50 maxi	2.75	2.780	5
	N277	PROTECTIVE DUCT GPC 120.120 GREY	MV 3x150 + 50 maxi	2.75	4.260	5
	N278	PROTECTIVE DUCT GPC 140.50 GREY	MV 3x240 maxi	2.75	3.060	5

Other ducts are available, in color or in aluminium. Please enquire.

IPC for MV BLL/BLX conductor



K251



K250

MICHAUD

Application

This I.P.C. (Insulation Piercing Connector) is designed to establish a tap connection from a medium voltage conductor type BLL/BLX (covered overhead conductor) to another BLL/BLX conductor. Connectors K250 and K251 can receive conductors section from 50mm² up to 241mm².

Description

- Insulation piercing of the main line and the tap line is carried out simultaneously.
- Contact bridges are studied to pierce an insulation thickness up to 3mm maximum.
- Tightening screws are potential free.
- Tightening efficiency is ensured by shear head screws.
- Connectors K250 and K251 can receive respectively main and tap conductors as follows:
 - 50-157/50-157mm²
 - 50-241mm²/50-241mm²
- IPC are delivered with a sealing end cap.

This connector meets the criteria of the **EN 50483-5-6** and **EN 50397-1-2** standards.

Installation

- Insert the insulated tap conductor into the connector. Adjust extra length and add the sealing cap at the end.
- Implement the connector on the main line and tighten the screw with a 17mm spanner until shear head breaks.
- The permanent head is only provided for eventual disassembly, do not use it to tighten the screw further after the first shear head has broken.

Code	Designation	Contact bridge	Main line insulated Al-Cu (mm ²)	Tap line insulated Al-Cu (mm ²)	Weight (kg)	Sales unit
ZINC PLATED STEEL FASTENERS						
K250	IPC 50-157 BLL/BLX	Tinned copper	50-157	50-157	0.640	18
K251	IPC 50-241 BLL/BLX	Tinned copper	50-241	50-241	0.810	18

Discover all our products on the website www.michaud-export.com

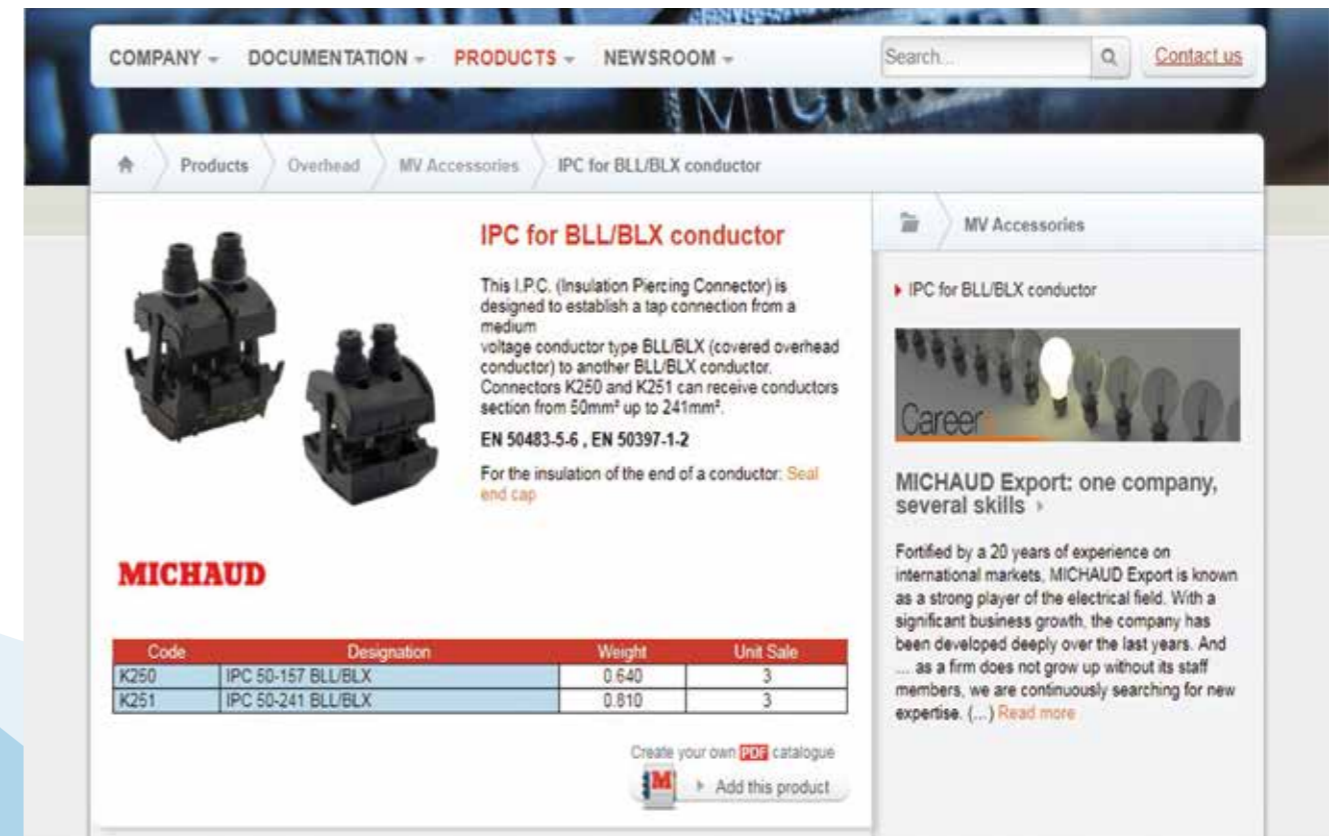

Protection

Protection

Service protection

Fuse switch disconnecter 100A, 22x58, 35 ²	p.88
Fuse switch disconnecter 100A, 22x58, 95 ²	p.90
Fuse switch disconnecter 160A, NH 00, 95 ² + 120 ²	p.92
Fuse switch connector 20A, 10.3x38, 95 ²	p.94
Fuse switch connector 100A, 22x58, 150 ²	p.96
Fuse cutout sleeve 100A, 22x58, 35 ²	p.98
Fuse insulation piercing pit connector 100A, 22x58, 50 ²	p.100

Network protection

Fuse switch disconnecter double pole 160A, NH 00, 95 ² + 120 ²	p.102
Fuse switch disconnecter triple pole 160A, NH 00, 95 ² + 120 ²	p.104
Fuse switch disconnecter quadruple pole 160A, NH 00, 95 ² + 120 ²	p.106
Operating stick	p.108

Fuses

Fuse cartridge gG.....	p.110
Fuse cartridge AD.....	p.112
Fuse cartridge NH1 and NH2.....	p.114



For a safe and effective electrical line, MICHAUD offers solutions for the protection of individual premises as well as low voltage network.



Lasting installations

As a specialist in low voltage distribution, MICHAUD gets involved in the networks **performance optimisation** and the guarantee of long-lasting electrical lines.



Protected networks

Thanks to protections installed in **strategic points** on the network or on service level, the power company takes advantage of a better control of faults propagation and an easier maintenance.



Customized products

The technical skills and the right understanding of problematics on the field enable to propose **suitable solutions** for specific demands (customer identification on the product, easy handling, fuse blown indicator...).

Service protection

Two solutions can be used for individual houses protection: the **fuse switch disconnector** or the **cutout sleeve**. These devices enable a possible cutting point facilitating every interventions for the network manager.

Comparison between	Fuse switch disconnector	and	Cutout sleeve
Manipulation ease	++		+
	From ground level with a stick		On top pole
Economical solution	+		++

A solution for the protection in underground environment

In order to adapt to various specifications met on the field, a partially and temporarily submersible solution, has been designed to ensure the protection of the underground network connection.

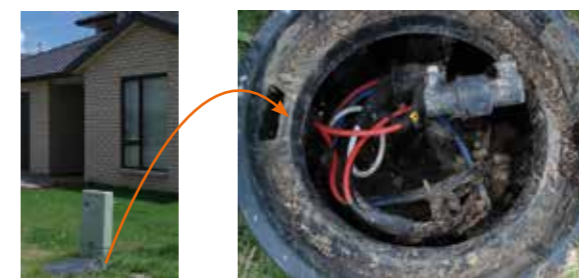

- ✓ Installation in a pit
- ✓ Working temporarily into water
- ✓ Full waterproof connection

Network protection

Low voltage networks are usually **structured in a star shape** from the LV/MV transformer and are not looped. A single short-circuit could therefore make an entire network fail, creating customer service disruptions.

MICHAUD solution: protection on strategic points

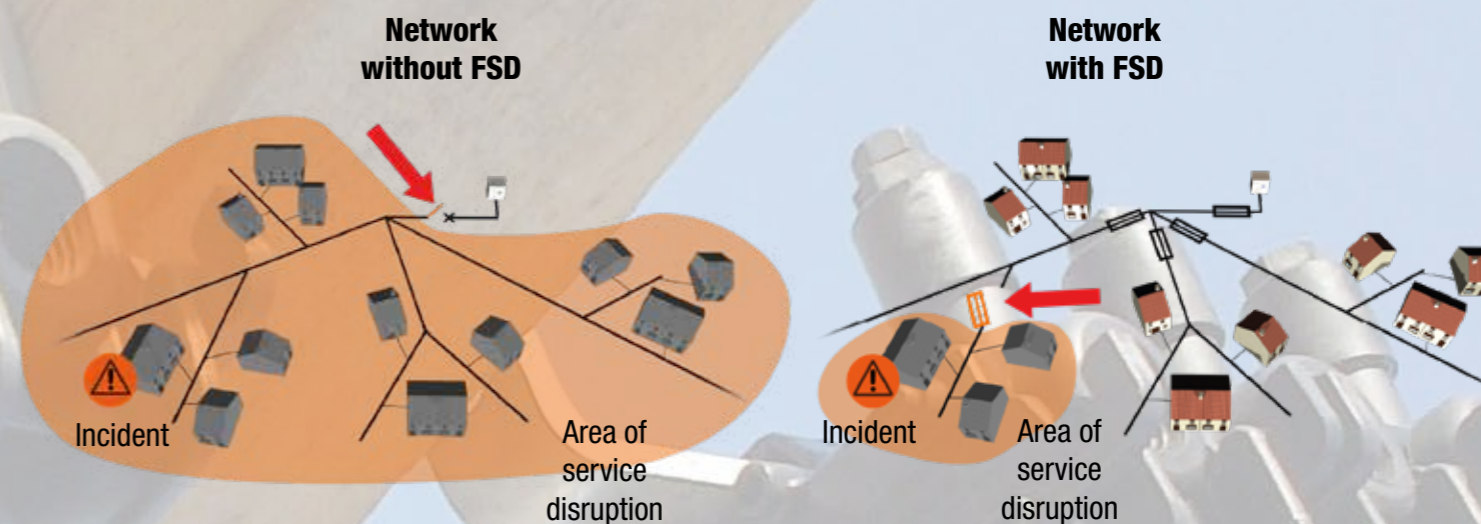

- ✓ Control of faults propagation
- ✓ Reduction of customers discontents

+ A suitable earth system device enables the temporary fuse switch protection for work.

SEE SHEET
Earth system / Switch earthing and short circuiting device fort gang FSD





Installation video available on www.michaud-export.com
(tab Documentation > Installation videos)

The benefits:

- + 50 up to 80% more economical than a circuit breaker
- + Strong solution, very little sensitive to charge imbalances
- + Solution available in single and three phases



Fuse switch disconnecter: many options for all configurations

Two types of protections

Service protection

Rating 100A or 160A

Fuse size 22x58 or NH 00

Conductors section max 35mm², 95mm² or 120mm²

- ✓ Single phase FSD

Network protection

Rating 160A

Fuse size NH 00

Conductors section max 95mm² or 120mm²

- ✓ Multi-phase FSD
- ✓ Available in 2, 3, 4, 6 poles

Many options

P

Fuse presence indicator

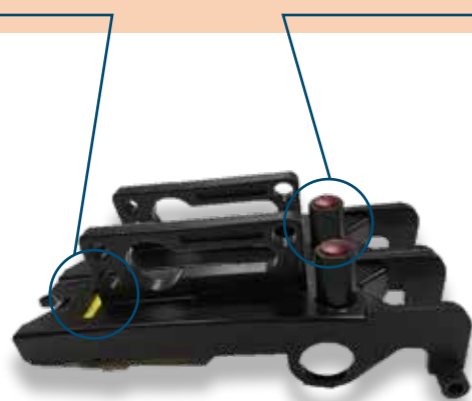

Check the fuse presence

L

Blown fuse LED light



Be aware of a blown fuse

H

Shear head indicator

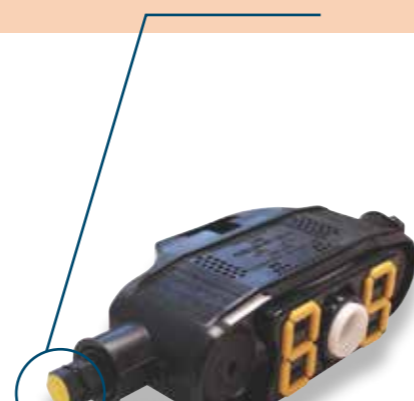

Check from ground level the good sheared-off of the head

N

Customer identification number



Identify the line or customer number

S

Neutral simultaneous cut

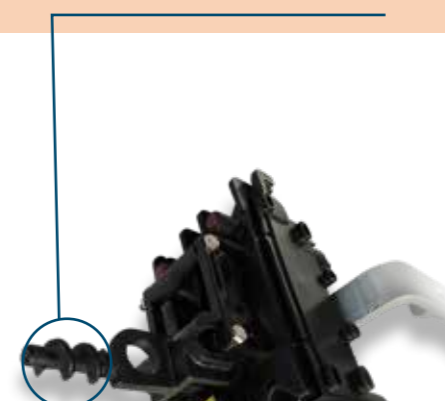

Enable the simultaneous cut of phases and neutral

C

Color of the fuse carrier



Distinguish phases and neutral

Fuse switch disconnecter 100A



MICHAUD

Application

This Fuse Switch Disconnecter (FSD) is a single phase device. It is installed at the top of pole or on façade. It protects the overhead connection supplying an individual customer and the low voltage network. It is designed to receive a neutral tube or 100A maximum, size 22x58 fuse cartridge (according to the IEC 269-2.1 standard).

- Rating** 100A
- Fuse size** 22x58
- Conductors section** 6-35mm²

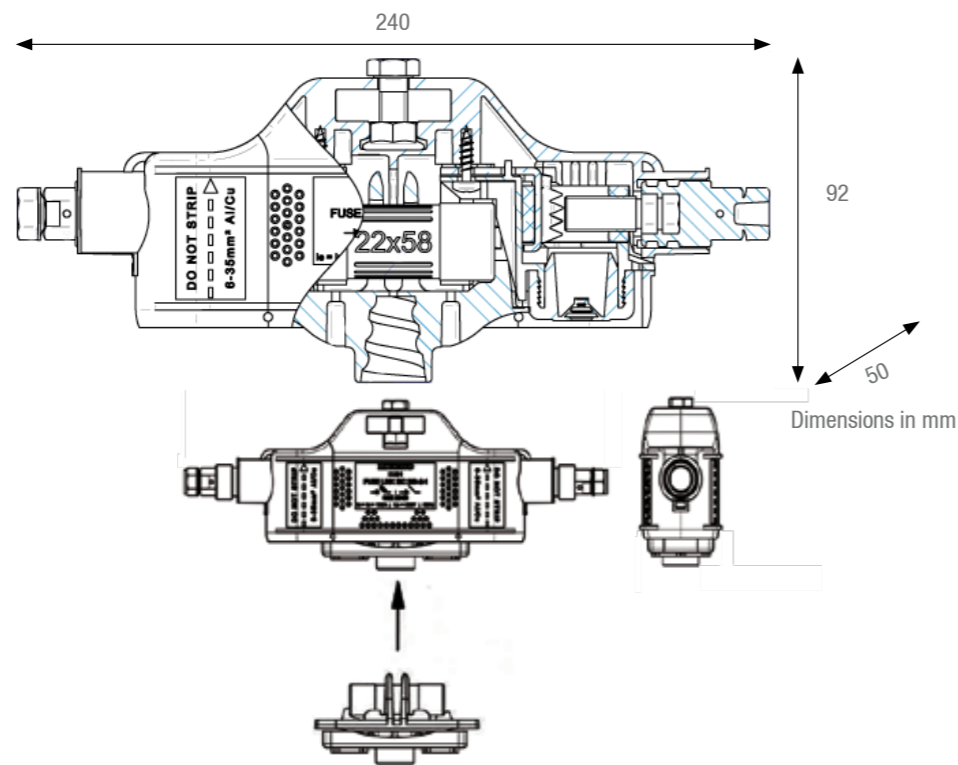

Description

- The FSD ratings are:
 - Rated voltage, Ue : 500V
 - Rated frequency : 50 up to 60Hz
 - Rated insulation voltage, Ui : 1 000V
 - Rated current, Ie : 100A
- The terminals are completely insulated. Connection is established using insulation piercing technology.
- The insulated conductor section ranges from 6 up to 35mm² Al/Cu.
- The tightening efficiency of the conductors is ensured by two shear head screws located on side body.
- The conductors inserting is performed from below.
- The fuse holder is opened, removed and closed using a pigtail stick.
- Note: the fuse holder can be installed without fuse.
- Screw heads and the fuse carrier can be sealed if necessary. The protection degree is IP33.

This fuse switch disconnecter meets the criteria of the **IEC 60 947-3** and **IEC 60 269-2** standard.

Code	Designation	Weight (kg)	Sales unit
K491	SINGLE PHASE FSD 100A (22x58) PIERCING 6-35	0.385	20

Customised solution:

Several options available:

- For the shear head indicator, add **H** to the reference.
- For the customer identification number, add **N** to the reference.
- For the colour of the fuse carrier, add **C** to the reference and specify the colour (white is standard colour).



Option: Number plate alone

Code	Designation	Weight (kg)	Sales unit
K492	NUMBER PLATE FOR FSD K491 / CABLE	0.025	100



Accessories

The bracket is made of galvanised steel highly resistant to corrosion. Fixing on a pole or façade is achieved by two 10mm diameter galvanised steel screws and two holes on the bracket (top hole having a key shape to make it easier to position the FSD). The adaptor made of synthetic materials is designed to fix a fuse switch disconnecter on a "swan neck" type bracket. It can also be fixed using a strap or 2 screws.



Code	Designation	Weight (kg)	Sales unit
K297	METAL BRACKET FOR SINGLE PHASE FSD	0.490	30
K295	PLASTIC ADAPTOR FOR SINGLE PHASE FSD BRACKET	0.070	5

SEE SHEET PROTECTION / Operating stick

SEE SHEET PROTECTION / Fuses

Fuse switch disconnecter 100A



K291

Rating 100A

Fuse size 22x58

Conductors section 6-95mm²

MICHAUD

Application

This Fuse Switch Disconnecter (FSD) is a single phase device. It is installed at the top of pole or on façade. It protects the overhead connection supplying an individual customer and the low voltage network.

It is designed to receive a neutral tube or a 100A maximum, size 22x58 fuse cartridge (according to the **IEC 269-2.1** standard).

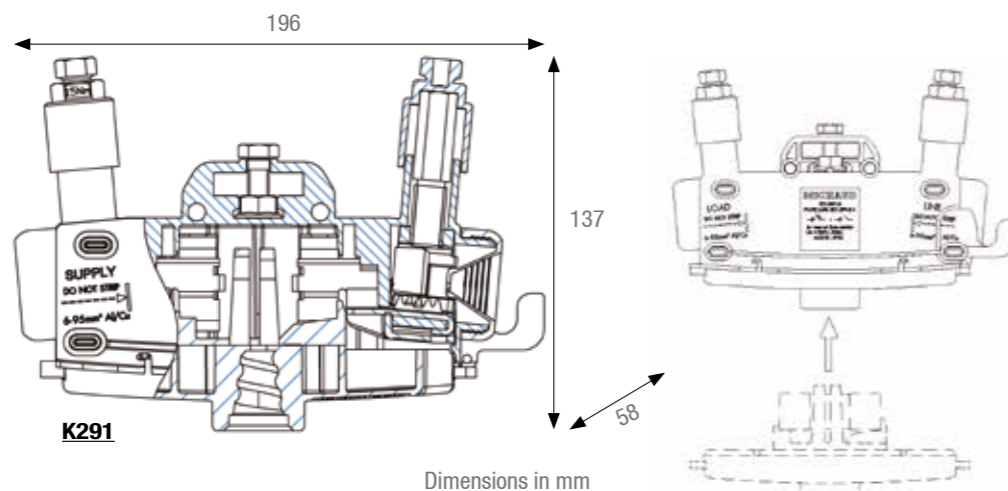

Dimensions in mm

Description

- The FSD ratings are:
 - Rated voltage, Ue : 500V
 - Rated frequency : 50 up to 60Hz
 - Rated insulation voltage, Ui : 1 000V
 - Rated current, Ie : 100A
- The terminals are completely insulated. Connection is established using insulation piercing technology.
- The insulated conductor section ranges from 6 up to 95mm² Al/Cu.
- The tightening efficiency of the conductors is ensured by two shear head screws on top body.
- The fuse holder is opened, removed and closed using a pigtail stick.
- Note: the fuse holder can be installed without fuse.
- The polarity test points are accessible on each terminal without removing the fuse holder.
- The fuse holder can be sealed if necessary. The protection degree is IP33.

This fuse switch disconnecter meets the criteria of the **IEC 60 947-3** and **IEC 60 269-2** standards.

Code	Designation	Weight (kg)	Sales unit
K291	SINGLE PHASE FSD 100A (22x58) PIERCING 6-95	0.510	1

Customised solution:

Several options available:

- For the fuse presence indicator, add **P** to the reference.
- For the blown fuse LED indicator, add **L** to the reference. (Use a NH 00 fuse carrying metal fixing bracket linked to the blade)
- For the shear head indicator, add **H** to the reference.
- For the customer identification number, add **N** to the reference.
- For the colour of the fuse carrier, add **C** to the reference and specify the colour (black is standard colour).

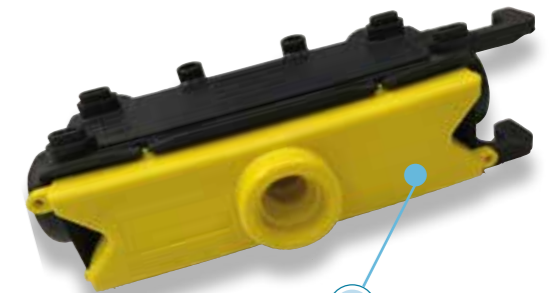

K291-C

Colour of the fuse carrier



Blown fuse LED indicator

Fuse presence indicator

Customer identification number

K291-P-L-N

Accessories

The bracket is made of galvanised steel highly resistant to corrosion. Fixing on a pole or façade is achieved by two 10mm diameter galvanised steel screws and two holes on the bracket (top hole having a key shape to make it easier to position the FSD).

The adaptor made of synthetic materials is designed to fix a fuse switch disconnecter on a "swan neck" type bracket. It can also be fixed using a strap or 2 screws.



K297

K295

Code	Designation	Weight (kg)	Sales unit
K297	METAL BRACKET FOR SINGLE PHASE FSD	0.490	30
K295	PLASTIC ADAPTOR FOR SINGLE PHASE FSD BRACKET	0.070	5

SEE SHEET PROTECTION / Operating stick

SEE SHEET PROTECTION / Fuses

Fuse switch disconnecter 160A



K292
Insulation piercing



L277
Stripping

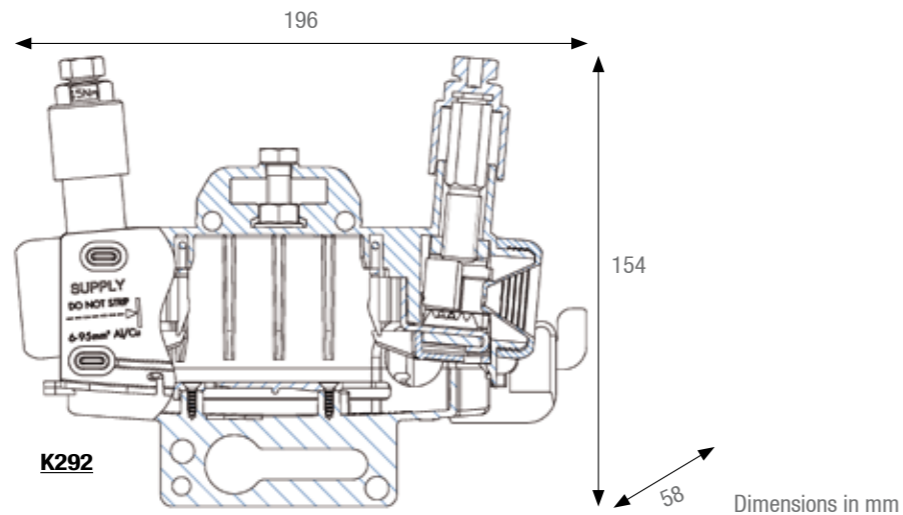

MICHAUD

Application

This Fuse Switch Disconnecter (FSD) is a single phase device. It is installed at the top of pole or on façade. It protects the overhead connection supplying an individual customer and the low voltage network. It is designated to receive a 160A fuse cartridge or 240A maximum solid connecting link size 00 (according to the IEC 269-2.1 standard).

Rating 160A

Fuse size NH 00

Conductors section

6-95mm² (K292), 6-120mm² (L277)

Description

- The FSD ratings are:
 - Rated voltage, Ue : 500V
 - Rated frequency : 50 up to 60Hz
 - Rated insulation voltage, Ui : 1 000V
 - Rated current, Ie : 160A
- The terminals are completely insulated.
- The FSD K292 uses the insulation piercing technology and receives insulated conductors from 6 up to 95mm² Al-Cu (entry seals are of black colour).
- The FSD L277 uses the stripping technology and receives insulated conductors from 6 up to 120mm² Al-Cu (entry seals are of grey colour).
- The tightening efficiency of the conductors is ensured by two shear head screws on top body.
- The fuse holder is opened, removed and closed using a hook stick.
- Note: the fuse holder can be installed without fuse.
- The polarity test points are accessible on each terminal without removing the fuse holder.
- The fuse carrier can be sealed if necessary. The protection degree is IP33.

This fuse switch disconnecter meets the criteria of the IEC 60 947-3 and IEC 60 269-2 standards.

Code	Designation	Weight (kg)	Sales unit
K292	SINGLE PHASE FSD 160A (NH 00) PIERCING 6-95	0.470	1
L277	SINGLE PHASE FSD 160A (NH 00) STRIPPING 6-120	0.470	1

Customised solution:

Several options available:

- For the presence indicator, add **P** to the reference.
- For the blown fuse LED indicator, add **L** to the reference. (Use a NH 00 fuse carrying metal fixing bracket linked to the blade)
- For the shear head indicator, add **H** to the reference.
- For the colour of the fuse carrier, add **C** to the reference and specify the colour (black is standard colour).



Option: Fuse carrier alone

Fuse carriers L297 and L298 can be used with existing MICHAUD fuse switch disconnectors size 00 on the field for retrofit operations, adding indicators.

Code	Designation	Weight (kg)	Sales unit
L297	FUSE CARRIER (Size 00) WITH BLOWN FUSE INDICATOR	0.091	1
L298	FUSE CARRIER (Size 00) WITH DISPLAY & BLOWN FUSE INDICATORS	0.091	1

Accessories

The bracket is made of galvanised steel highly resistant to corrosion. Fixing on a pole or façade is achieved by two 10mm diameter galvanised steel screws and two holes on the bracket (top hole having a key shape to make it easier to position the FSD). The adaptor made of synthetic materials is designed to fix a fuse switch disconnecter on a "swan neck" type bracket. It can also be fixed using a strap or 2 screws.



Code	Designation	Weight (kg)	Sales unit
K297	METAL BRACKET FOR SINGLE PHASE FSD	0.490	30
K295	PLASTIC ADAPTOR FOR SINGLE PHASE FSD BRACKET	0.070	5

SEE SHEET
INSTALLATION / LV insulated toolings

SEE SHEET
PROTECTION / Operating stick

SEE SHEET
PROTECTION / Fuses

Fuse switch connector 20A

Protection

Rating 20A

Fuse size 10.3x38

Conductors section 16-95mm²/
1.5-16mm² depending on the versions



K223 and K224

K228 and K229

Application

This fuse switch connector is designed to receive a 10.3x38mm fuse cartridge or neutral tube. It is used to protect street light or insulated service conductors connected to the low voltage A.B.C. (Aerial Bundled Conductors) or bare line conductors. It is designed for 20A maximum fuse cartridge. It is used in no mechanical load situations.

The benefit:

+ Unlosable fuse carrier

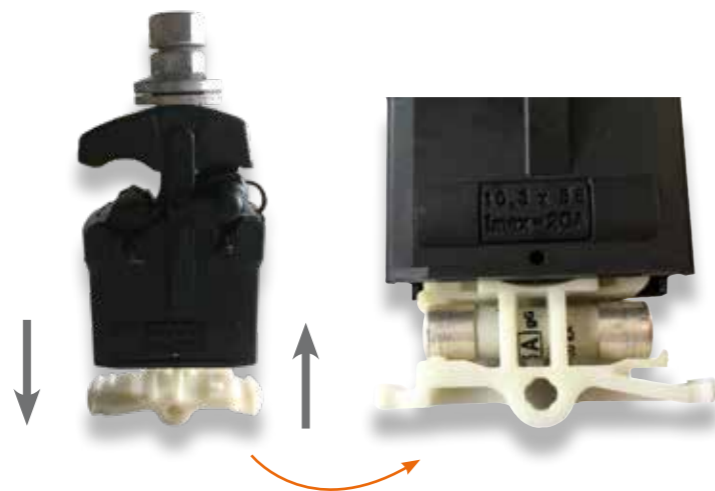

Description

- Tightening of the bare or insulated main line conductor and piercing on the tap line conductor are carried out simultaneously in a single operation.
- The sealing end cap is flexible in order to check good tap conductor insertion. It can be installed with service cable outlet on left or right side.
- Tightening efficiency is ensured by a shear head screw.
- An elastomer compound ensures insulation during piercing of the conductors to be connected.
- Connection of the fuse cartridge on the tuning fork contacts is ensured using springs.
- The sealable fuse holder is operated easily by hand. Two arrows engraved on the side of the box indicate the opening and closing direction to be followed.
- The protection degree is IP2X during installation. It becomes IP33 after installation on the insulated conductor.

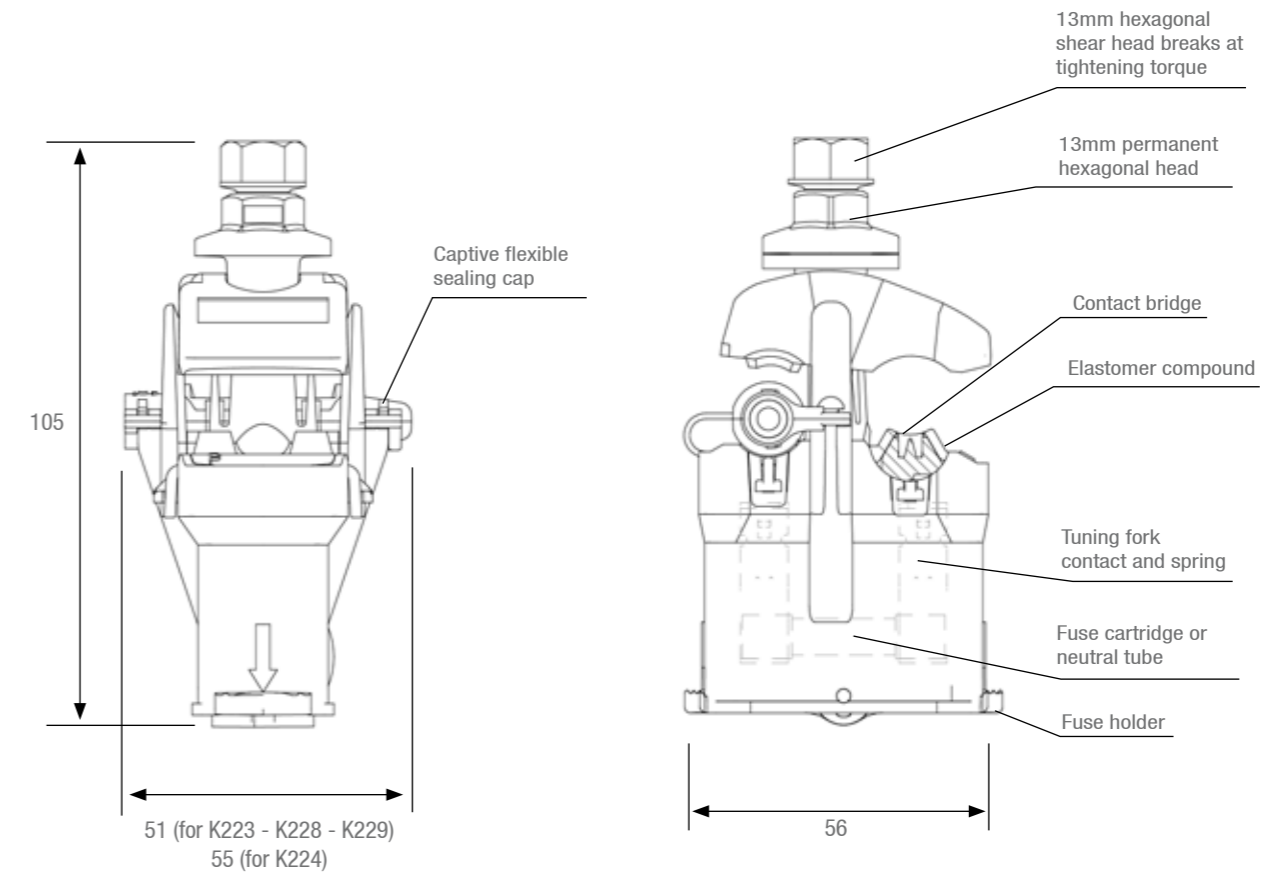

Dimensions in mm

Code	Designation	Capacities Main (mm ²)	Capacities Tap insulated Al-Cu (mm ²)	Weight (kg)	Sales unit
K223	FUSE CONNECTOR 20A (10.3x38) PIERCING 95/10	Al / Cu Insulated 16-95	1.5-10	0.130	10
K224	FUSE CONNECTOR 20A (10.3x38) PIERCING 95/16	Al / Cu Insulated 16-95	6-16	0.130	10
K228	FUSE CONNECTOR 20A (10.3x38) BARE Cu 95/10	Cu bare 16-95	1.5-10	0.130	10
K229	FUSE CONNECTOR 20A (10.3x38) BARE Al 95/100	Al bare 16-95	1.5-10	0.130	10

Protection

Fuse switch connector 100A

Protection

Rating 100A

Fuse size 22x58

Conductors section
35-150mm² / 6-35mm²



K210

MICHAUD

Application

This fuse switch connector is designed to receive a 22x58mm fuse cartridge or neutral tube. It is used to protect the insulated service conductors connected to a low voltage A.B.C. (Aerial Bundled Conductors). It is used in no mechanical load situations. Opening and closing of the cutout can be performed under a load of 63A maximum.

Description

- Insulation piercing on the main and tap conductors is carried out independently.
- Tightening efficiency is ensured by shear head screws. The dielectric strength in water is greater than 6kV.
- An elastomer compound ensures insulation during piercing of the conductors to be connected.
- The spring tightening on the cartridge is calibrated so that when the cutout is opened, the cartridge remains on the customer side (therefore without voltage).
- Once the cartridge has been installed, the cutout is locked using the closing ring.
- The closing ring and the 13mm permanent head can be sealed.



K210

Code	Designation	Capacities Main insulated Al-Cu (mm ²)	Capacities Tap insulated Al-Cu (mm ²)	Weight (kg)	Sales unit
K210	FUSE SWITCH CONNECTOR 63A (22x58) PIERCING 150/35	35-150	6-35	0.310	10

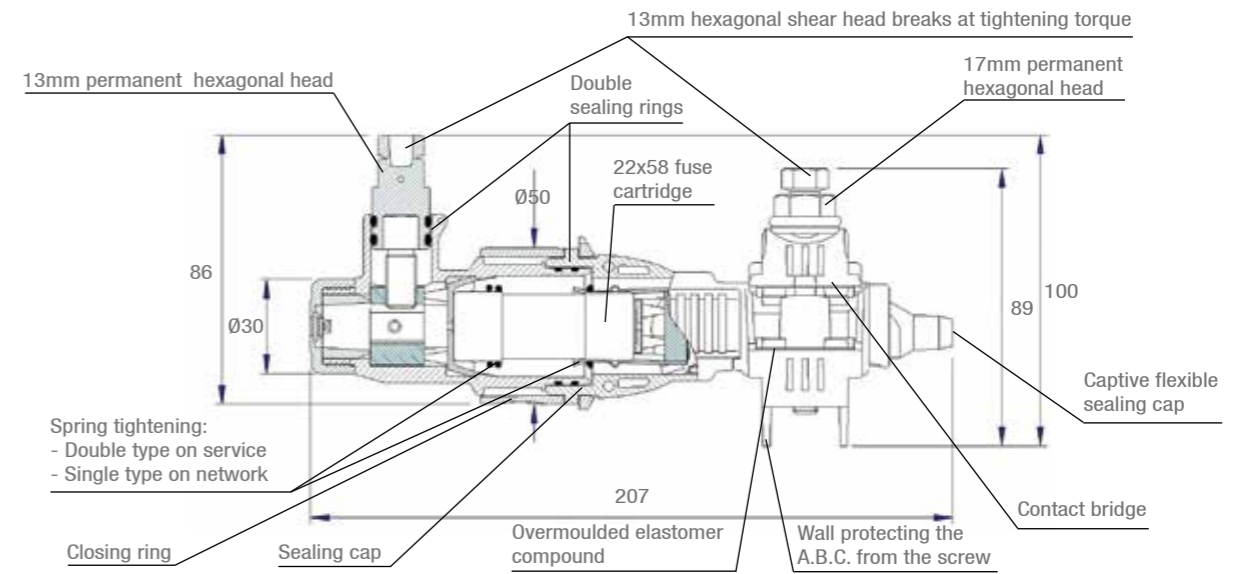

Dimensions in mm

SEE SHEET
INSTALLATION / LV insulated toolings

SEE SHEET
PROTECTION / Fuses

Protection

Fuse cutout sleeve 100A

Protection

Rating 100A
Fuse size 22x58
Conductors section
6-35mm² (K221), 16-35mm² (K219)

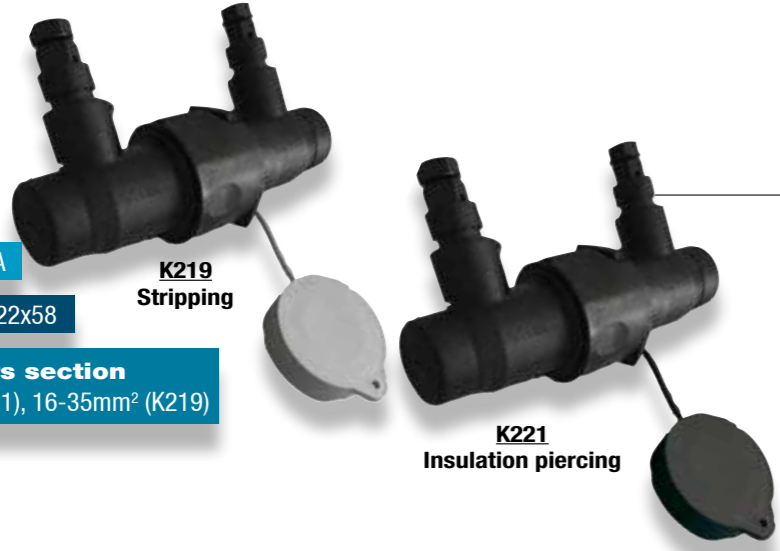

MICHAUD

Application

This cutout sleeve is designed to receive a 22x58 fuse cartridge, a neutral tube or a mini-switch. It is used in no mechanical load situations. It is equipped with mechanical tightening terminals allowing its installation using a simple spanner. Opening and closing of the cutout can be performed under a load of 63A maximum.

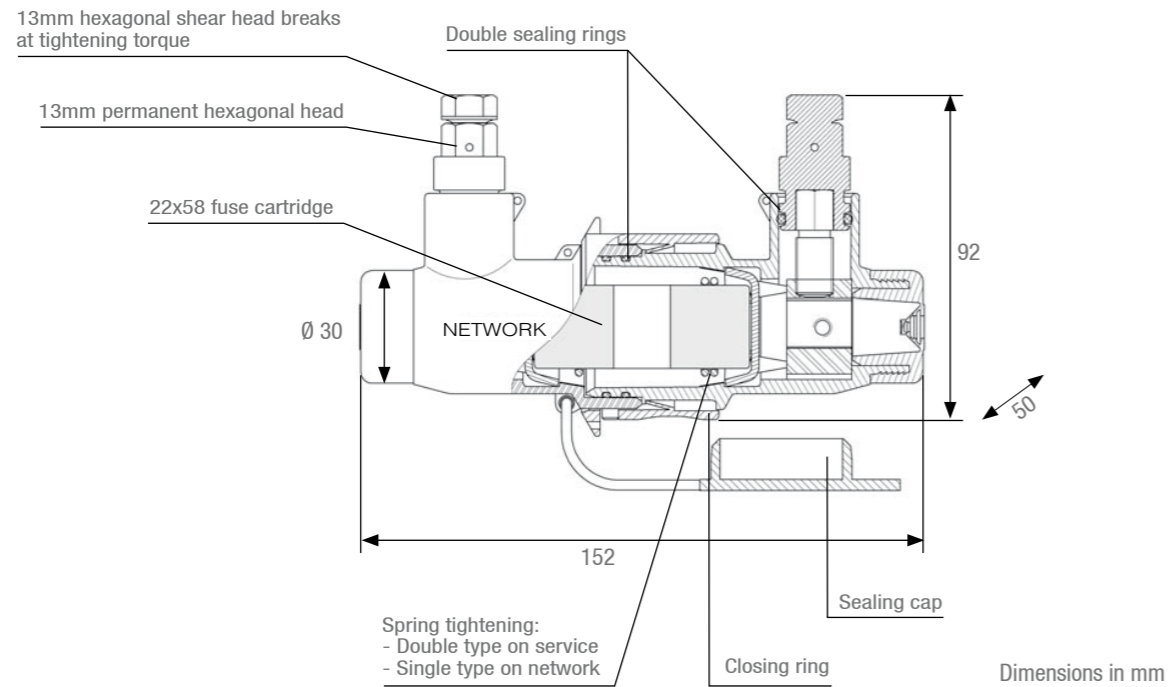

Description

- Connection is established using insulation piercing technology for the K221 and stripping technology for the K219. The tightening screws are equipped with shear heads.
- The terminals offer the following capacities:
 - 6-35mm² Al/Cu or 16M-50M Al for the K221,
 - 16-35mm² Al/Cu or 16M-50M Al for the K219.
- The product has a dielectric strength in water greater than 6kV.
- The spring tightening on the cartridge is calibrated so that when the cutout is opened, the cartridge remains on the customer side (therefore without voltage).
- A sealing cap temporarily protects the access on the network side (black on K221 ; grey on K219).
- Once the cartridge has been installed, the product is locked using the closing ring.
- The closing ring and the 13mm screw can be sealed.
- The sleeve accepts 63A fuses. The 100A fuse is only accepted with 35mm² copper wiring.

This sleeve meets the criteria of the **ErDF 69 40 070** French specification.



Protection

Code	Designation	Weight (kg)	Sales unit
K221	CUTOUT SLEEVE 63A (22x58) PIERCING 6-35	0.235	70
K219	CUTOUT SLEEVE 63A (22x58) STRIPPING 16-35	0.235	70

Alternative: Cutout sleeve with 50A

The cutout sleeve is also available in 14x51. It accepts fuses up to 50A and Al/Cu conductors from 2.5 to 16mm². Connection is established by stripping the conductor. Connection is ensured by a shear head screw that cannot be dismantled.

Rating 50A
Fuse size 14x51
Conductors section
2.5-16mm²

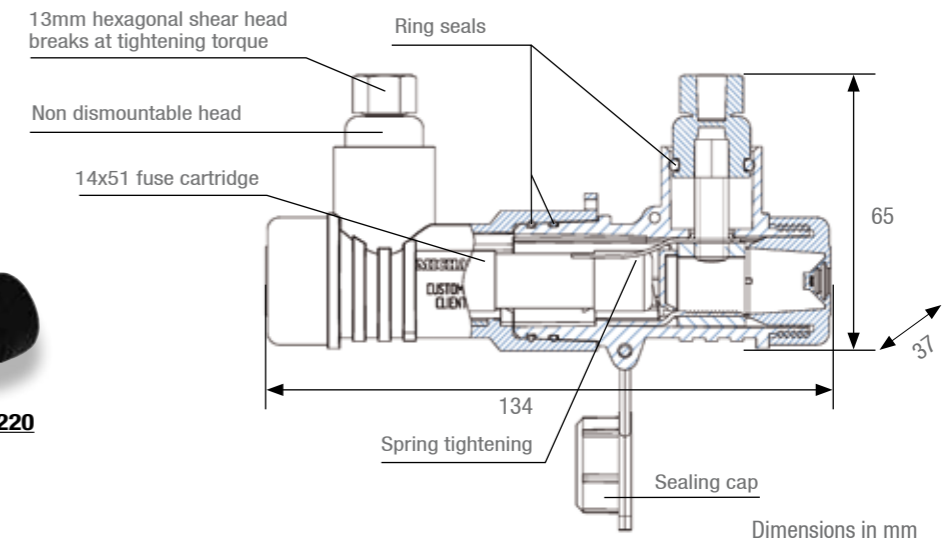

Code	Designation	Weight (kg)	Sales unit
K220	CUTOUT SLEEVE 50A (14x51) 2.5-16	0.195	20

SEE SHEET
INSTALLATION / LV insulated toolings

SEE SHEET
PROTECTION / Fuses

Fuse insulation piercing pit connector 100A

Protection

- Rating** 100A
- Fuse size** 22x58
- Conductors section** 6-50mm²



MICHAUD

Application

This Fuse Insulation Piercing Pit Connector (IPPC) is designed to receive a neutral tube, a mini-switch or a 100A maximum, size 22x58 fuse cartridge. It is used to connect a customer service line to an underground conductor. It is installed in a pit and can operate partially and temporary immersed in water. It is equipped with mechanical tightening terminals allowing its installation on a conductor using a simple spanner.

K199

Description

- Terminals use insulation piercing technology.
- Tightening efficiency is ensured by shear head screws.
- The connection is totally watertight.
- The terminals offer a capacity from 6 up to 50mm² Al/Cu.
- The elastic tightening of the cartridge is calibrated so that when the connector is opened, the cartridge remains on the customer side (therefore without voltage).
- A sealing cap temporarily protects the access on the network side.
- Once the cartridge is installed, the connector is locked using the closing ring.

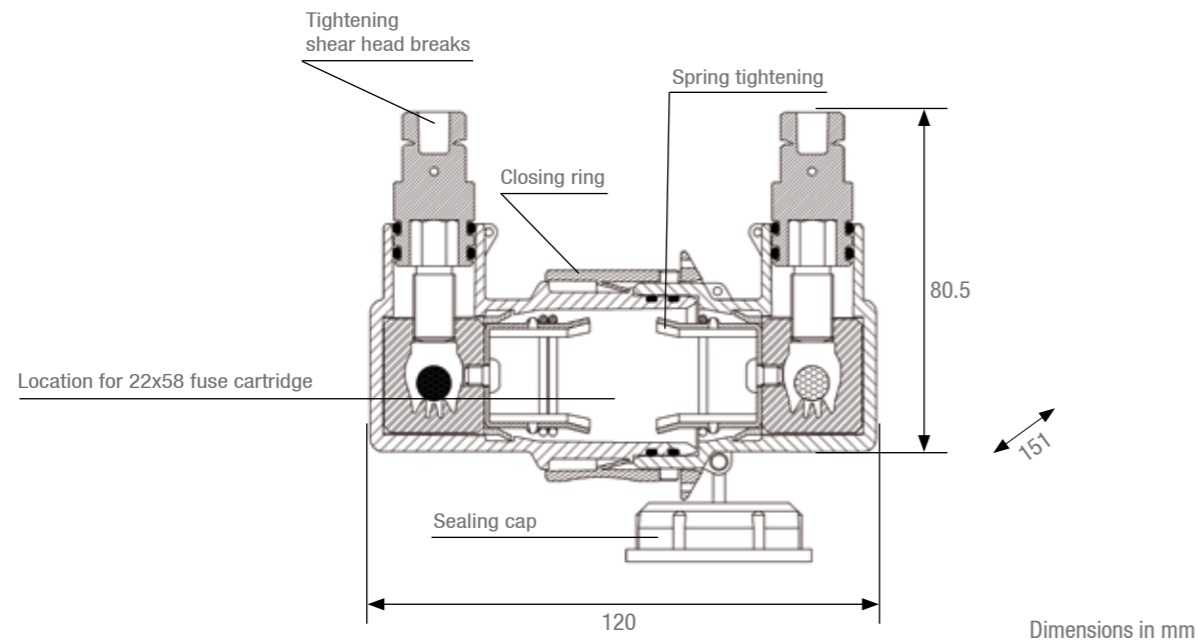

Protection

Code	Designation	Weight (kg)	Sales unit
K199	FUSE INSULATION PIERCING PIT CONNECTOR 100A (22x58) PERFO 6-50	0.302	10

SEE SHEET
INSTALLATION / LV insulated toolings

SEE SHEET
PROTECTION / Fuses

Fuse switch disconnecter double pole 160A

Rating 160A

Fuse size NH 00

Conductors section

6-95mm² (K298), 6-120mm² (L278)

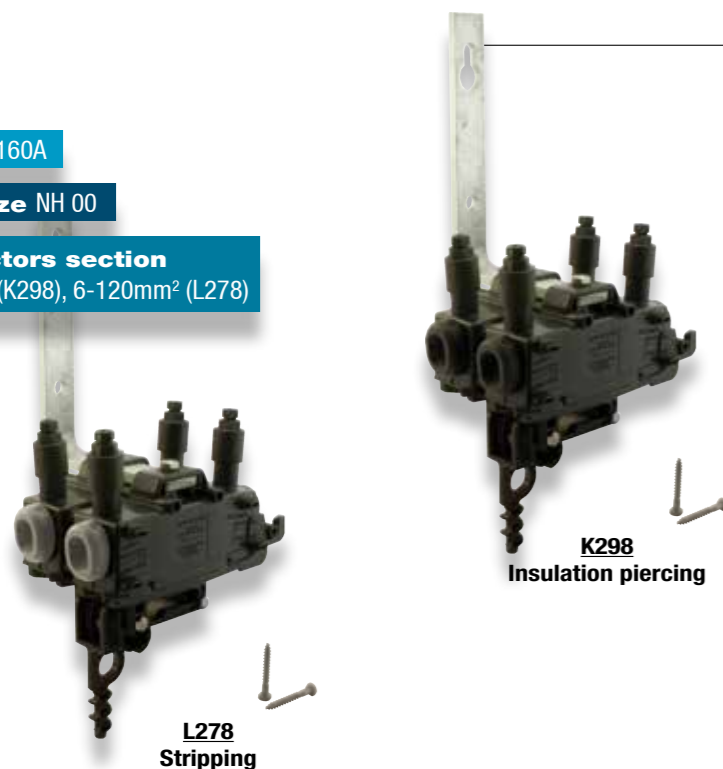

MICHAUD

Application

This Gang Fuse Switch Disconnecter (Gang FSD) is a multi-phase device. It is installed at the top of a pole or on façade. It protects the overhead connection supplying one or several multi-phase customers or the low voltage circuit of a pole mounted transformer. It is designed to receive 160A fuse cartridges or 240A solid connecting links, size 00 (according to the IEC 269-2.1 standard).

Description

Fuse Switch Disconnecter

- The FSD ratings are:
 - Rated voltage, Ue : 500V
 - Rated frequency : 50 up to 60Hz
 - Rated insulation voltage, Ui : 1 000V
 - Rated current, Ie : 160A
- The FSD K298 uses the insulation piercing technology and receives insulated conductors from 6 up to 95mm² Al-Cu (entry seals are of black colour).
- The FSD L278 uses the stripping technology and receives insulated conductors from 6 up to 120mm² Al-Cu (entry seals are of grey colour).
- The fuse holders are opened, removed and closed simultaneously using a hook stick or a stick to be screwed on the adaptor.
Note: the fuse holder can be installed without fuse.
- The polarity test points are accessible on each terminal without removing the fuse holder.
- The protection degree is IP33.

Bracket

- The bracket is available in 2 holes type. It is made of galvanised steel highly resistant to corrosion.
- Fixing on a pole or façade is achieved by two 10mm diameter galvanised steel screws and two holes on the bracket (top hole having a key shape to make it easier to position the Gang FSD).

This fuse switch disconnecter meets the criteria of the IEC 60 947-3 and IEC 60 269-2 standards.

Code	Designation	Weight (kg)	Sales unit
K298	DOUBLE POLE FSD 160A (NH 00) PIERCING 6-95	1.850	1
L278	DOUBLE POLE FSD 160A (NH 00) STRIPPING 6-120	1.850	1

Note: Fixing with two 10mm diameter galvanised steel screws is provided with the disconnecter.

Customised solution:

Several options available:

- For the fuse presence indicator, add **P** to the reference.
- For the blown fuse LED indicator, add **L** to the reference.
(Use a NH 00 fuse carrying metal fixing bracket linked to the blade)
- For the shear head indicator, add **H** to the reference.
- For the neutral simultaneous cut, add **S** to the reference.
- For the colour of the fuse carrier, add **C** to the reference and specify the colour (black is standard colour).

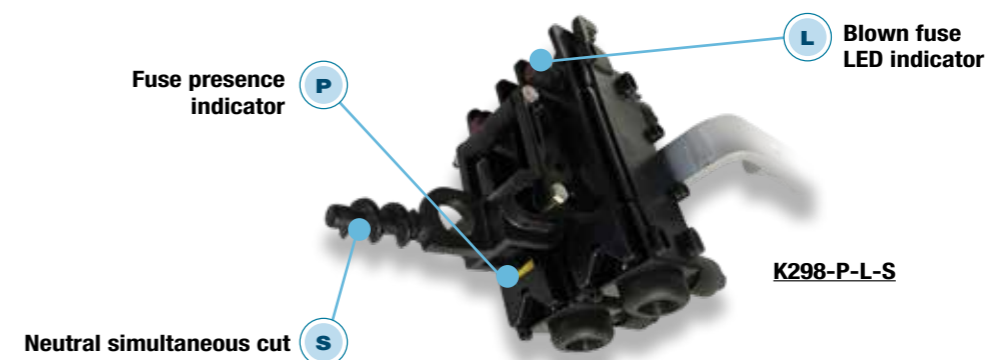

Option: Double tap

A double tap is available by adding an end connector with two insulation piercing taps. The conductor section goes from 6 up to 35mm² Al/Cu.

Code	Designation	Weight (kg)	Sales unit
K098	DOUBLE TAP END CONNECTOR (6-35mm ²)	0.110	12

SEE SHEET INSTALLATION / LV insulated toolings

SEE SHEET PROTECTION / Operating stick

SEE SHEET PROTECTION / Fuses

Fuse switch disconnecter triple pole 160A

Rating 160A
Fuse size NH 00
Conductors section
6-95mm² (K293), 6-120mm² (L284)

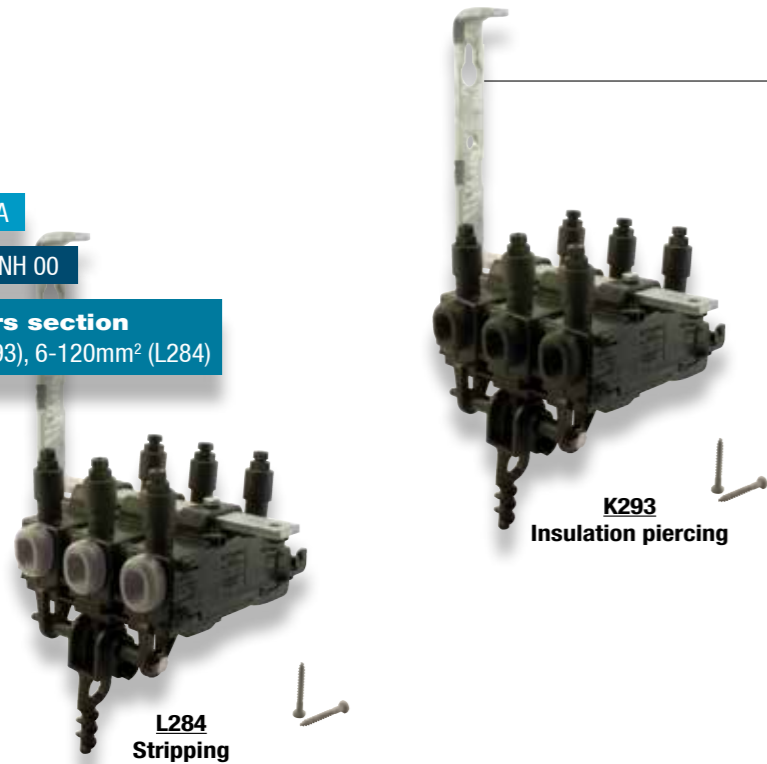

MICHAUD

Application

This Gang Fuse Switch Disconnecter (FSD) is a multi-phase device. It is installed at the top of a pole or on façade. It protects the overhead connection supplying one or more multi-phase customers or the low voltage circuit of a pole mounted transformer. It is designed to receive 160A fuse cartridge or 240A solid connecting links, size 00 (according to the IEC 269-2.1 standard).

Description

Fuse Switch Disconnecter

- The FSD ratings are:
 - Rated voltage, U_e : 500V
 - Rated frequency : 50 up to 60Hz
 - Rated insulation voltage, U_i : 1 000V
 - Rated current, I_e : 160A
- The FSD K293 uses the insulation piercing technology and receives insulated conductors from 6 up to 95mm² Al-Cu (entry seals are of black colour).
- The FSD L284 uses the stripping technology and receives insulated conductors from 6 up to 120mm² Al-Cu (entry seals are of grey colour).
- The fuse holders are opened, removed and closed simultaneously using a hook stick or a stick to be screwed on the adaptor.
Note: the fuse holder can be installed without fuse.
- The polarity test points are accessible on each terminal without removing the fuse holder.
- The protection degree is IP33.

Bracket

- The bracket is available in 4 holes type. It is made of galvanised steel highly resistant to corrosion. A hook at its end is used to fix a service cable anchoring clamp.
- Fixing on a pole or façade is achieved by two 10mm diameter galvanised steel screws and two holes on the bracket (top hole having a key shape to make it easier to position the Gang FSD). Fixing on poles can also be carried out using two stainless steel straps thanks to spurs on the bracket.

This fuse switch disconnecter meets the criteria of the IEC 60 947-3 and IEC 60 269-2 standards.

Code	Designation	Weight (kg)	Sales unit
K293	TRIPLE POLE FSD 160A (NH 00) PIERCING 6-95	2.710	1
L284	TRIPLE POLE FSD 160A (NH 00) STRIPPING 6-120	2.710	1

Note: Fixing with two 10mm diameter galvanised steel screws is provided with the disconnecter.

Customised solution:

Several options available:

- For the fuse presence indicator, add **P** to the reference.
- For the blown fuse LED indicator, add **L** to the reference. (Use a NH 00 fuse carrying metal fixing bracket linked to the blade)
- For the shear head indicator, add **H** to the reference.
- For the colour of the fuse carrier, add **C** to the reference and specify the colour (black is standard colour).

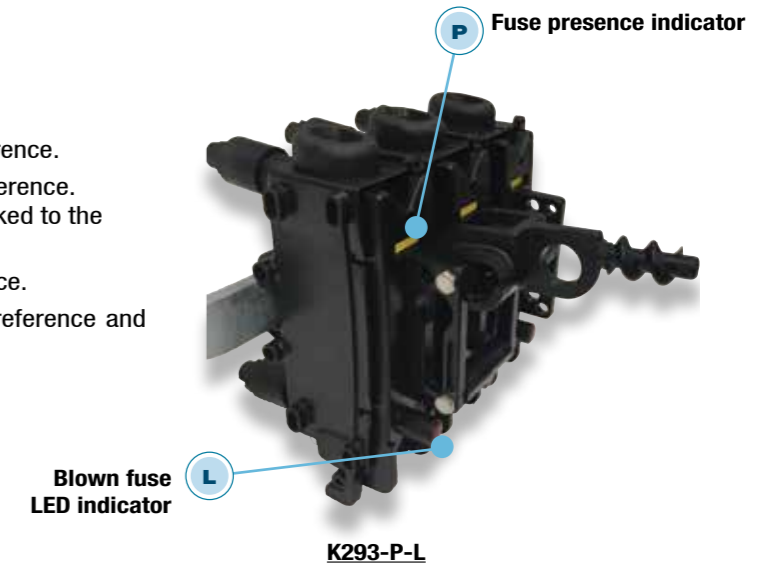

Option: Double tap

A double tap is available by adding an end connector with two insulation piercing taps. The conductor section goes from 6 to 35mm² Al/Cu.



Code	Designation	Weight (kg)	Sales unit
K098	DOUBLE TAP END CONNECTOR (6-35mm ²)	0.110	12

Alternative: Fuse switch disconnecter double triple pole 160A (size 00)

Code	Designation	Weight (kg)	Sales unit
K296	DOUBLE TRIPLE POLE FSD 160A (NH 00) PIERCING 6-95	3.800	1

Note: Fixing with two 10mm diameter galvanised steel screws is provided with the disconnecter.

SEE SHEET PROTECTION / Operating stick

SEE SHEET PROTECTION / Fuses

Fuse switch disconnecter quadruple pole 160A

Protection

Rating 160A
Fuse size NH 00
Conductors section
6-95mm² (K294), 6-120mm² (L281)

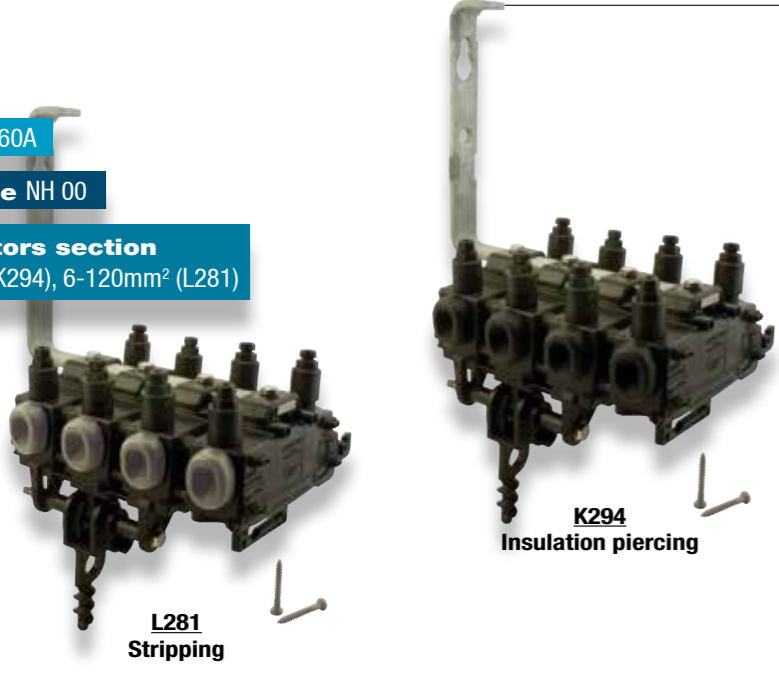

MICHAUD

Application

This Gang Fuse Switch Disconnecter (FSD) is a multi-phase device. It is installed at the top of a pole or on façade. It protects the overhead connection supplying one or more multi-phase customers or the low voltage circuit of a pole mounted transformer. It is designed to receive 160A fuse cartridge or 240A solid connecting links, size 00 (according to the IEC 269-2.1 standard).

Description

Fuse Switch Disconnecter

- The FSD ratings are:
 - Rated voltage, Ue : 500V
 - Rated frequency : 50 up to 60Hz
 - Rated insulation voltage, Ui : 1 000V
 - Rated current, Ie : 160A
- The FSD K294 uses the insulation piercing technology and receives insulated conductors from 6 up to 95mm² Al-Cu (entry seals are of black colour).
- The FSD L281 uses the stripping technology and receives insulated conductors from 6 up to 120mm² Al-Cu (entry seals are of grey colour).
- The fuse holders are opened, removed and closed simultaneously using a hook stick or a stick to be screwed on the adaptor (neutral cut-off is performed independantly).
Note: the fuse holder can be installed without fuse.
- The polarity test points are accessible on each terminal without removing the fuse holder.
- The quadruple pole FSD is equipped with a neutral blade contact size 00 integral with the fuse holder, on the neutral side (independent opening reaches to neutral cut).
- The protection degree is IP33.

Bracket

- The bracket is available in 4 holes type. It is made of galvanised steel highly resistant to corrosion. A hook at its end is used to fix a service cable anchoring clamp.
- Fixing on a pole or façade is achieved by two 10mm diameter galvanised steel screws and two holes on the bracket (top hole having a key shape to make it easier to position the Gang FSD). Fixing on poles can also be carried out using two stainless steel straps thanks to spurs on the bracket.

This fuse switch disconnecter meets the criteria of the IEC 60 947-3 and IEC 60 269-2 standards.

Protection

Code	Designation	Weight (kg)	Sales unit
K294	QUADRUPLE POLE FSD 160A (NH 00) PIERCING 6-95	3.240	1
L281	QUADRUPLE POLE FSD 160A (NH 00) STRIPPING 6-120	3.240	1

Note: Fixing with two 10mm diameter galvanised steel screws is provided with the disconnecter.

Costumised solution:

Several options available:

- For the fuse presence indicator, add **P** to the reference.
- For the blown fuse LED indicator, add **L** to the reference.
(Use a NH 00 fuse carrying metal fixing bracket linked to the blade)
- For the shear head indicator, add **H** to the reference.
- For the neutral simultaneous cut, add **S** to the reference.
- For the colour of the fuse carrier, add **C** to the reference and specify the colour (black is standard colour).



Option: Double tap

A double tap is available by adding an end connector with two insulation piercing taps. The conductor section goes from 6 to 35mm² Al/Cu.



Code	Designation	Weight (kg)	Sales unit
K098	DOUBLE TAP END CONNECTOR (6-35mm ²)	0.110	12

SEE SHEET INSTALLATION / LV insulated toolings

SEE SHEET PROTECTION / Operating stick

SEE SHEET PROTECTION / Fuses

Operating stick



F208

MICHAUD

Application

This telescopic operating stick is used to check that there is no voltage, to earth or to operate a fuse switch disconnector, remotely from the ground level. Each model is equipped with a notched universal U-shaped terminal end.

Description

- The stick and the extension comprise 1, 2 or 3 elements.
- Each element is made of glass fibre composite and has a high mechanical strength (IEC 1235 standard).
- The upper tube is filled with yellow foam to ensure the dielectric strength in the upper part.
- The hollowed lower tube receives the upper tube, in retracted position. It is entirely treated against humidity through siliconisation (the retracted or deployed position is locked using a push button).
- The work must be operated, with limited load at the top, with no mechanical stresses (twisting).
- The assembly can be used for low voltage applications at any time when the stick is deployed.
- The stick is equipped with the following elements:
 - A U-shaped notched universal end for fixing a suitable terminal end (wing nut equipped),
 - A second end with a mount equipped with a protected connection for the optional extension,
 - A hand grip for secure holding.
- The stick diameter is 42mm.
- The stick and the extension can be delivered in a protective cover in order to facilitate handling and storage.

Code	Designation	Elements number	Extension bar application	Length when closed (m)	Length when opened (m)	Weight (kg)	Sales unit
F200	OPERATING STICK 2E - 1.5M (TERMINAL END U)	2	No	0.85	1.50	1.050	1
F201	OPERATING STICK 2E - 2M (TERMINAL END U)	2	Yes	1.10	2.00	1.200	1
F202	OPERATING STICK 2E - 3.2M (TERMINAL END U)	2	Yes	1.75	3.20	1.500	1
F203	OPERATING STICK 2E - 5M (TERMINAL END U)	2	Yes	2.65	5.00	3.000	1
F204	OPERATING STICK 3E - 4.5M (TERMINAL END U)	3	No	1.65	4.50	3.000	1
F205	OPERATING STICK 3E - 5M (TERMINAL END U)	3	No	1.85	5.00	4.000	1
F206	OPERATING STICK 3E - 6M (TERMINAL END U)	3	No	2.50	6.00	5.000	1
F207	OPERATING STICK 1E - 1M	1	No	1.00	1.00	0.800	1
F208	PROTECTIVE COVER FOR OPERATING STICK	1	No	2.00	2.00	0.600	1

Terminal end



Application

To operate a Fuse Switch Disconnector (FSD) remotely from the ground level, the notched universal U-shaped threaded terminal end is fixed to the operating stick. The F210 end can be used to operate a Fuse Switch Disconnector manually, without loss of handling thanks to its handle shape.

Code	Designation	Weight (kg)	Sales unit
F209	BORED TERMINAL END DISCONNECTOR / STICK	0.105	10
F210	THREAD TERMINAL END DISCONNECTOR / STICK	0.035	10
F213	TERMINAL END TYPE L DISCONNECTOR / STICK	0.180	10

Installation

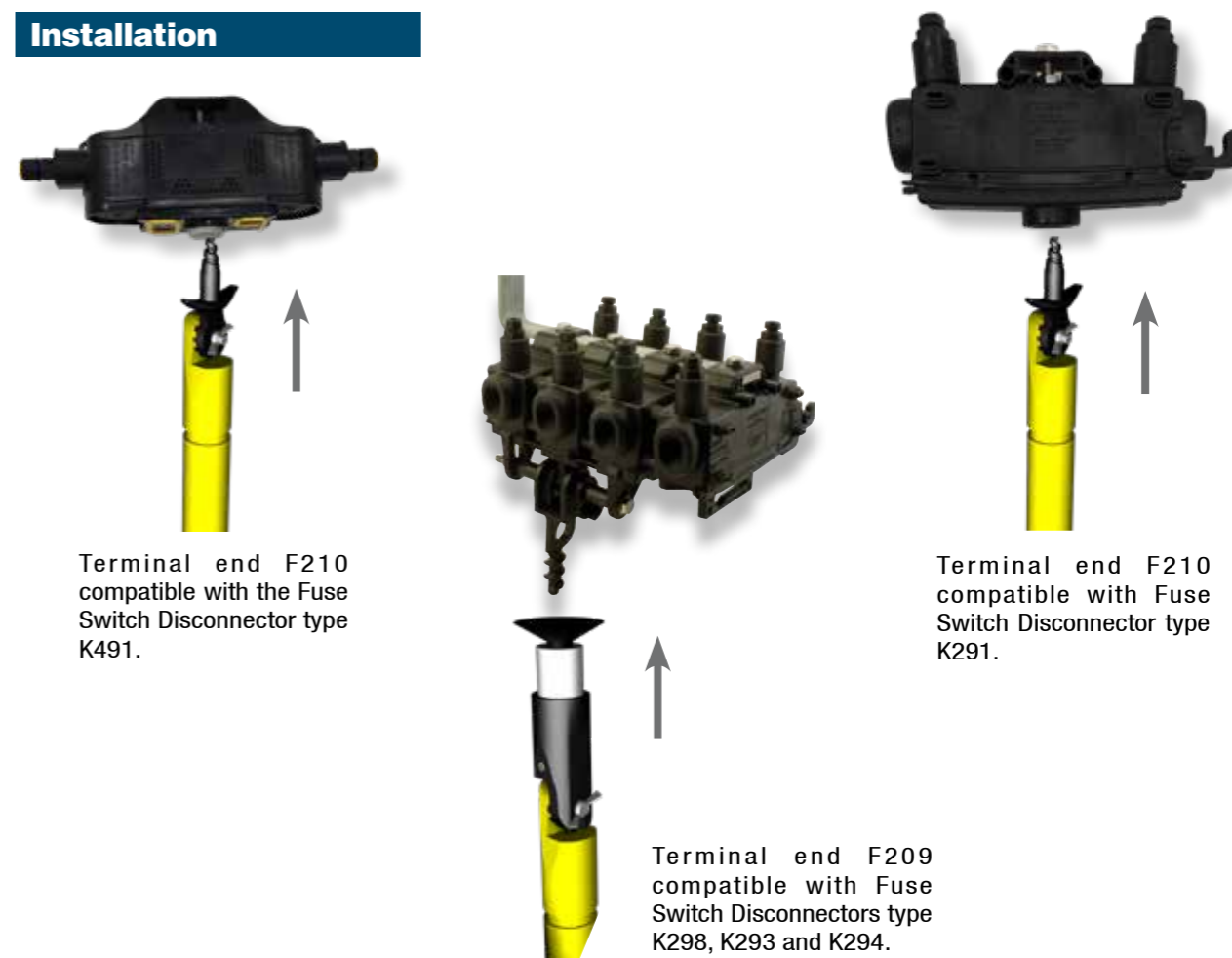

Terminal end F210 compatible with the Fuse Switch Disconnector type K491.

Terminal end F210 compatible with Fuse Switch Disconnector type K291.

Terminal end F209 compatible with Fuse Switch Disconnectors type K298, K293 and K294.

Nota : The F213 end is compatible with the Switch Disconnector type K292.

Fuse cartridge gG

MIRELEC

Application

These gG fuses cartridges are designed to protect goods. They are implemented in a cutout sheltered from outside weather conditions.



Type 10.3x38

Description

- This fuse cartridge is available in size 10.3x38mm.
- It is type gG HPC (High Breaking Capacity).
- It is not equipped with light indicator.

This fuse meets the criteria of the **NF/EN/IEC 60269-1**, **NF HD/IEC 60269-2**, **NF C 60200-1** and **NF C 60200-2** standards.



Type 14x51

Description

- This fuse cartridge is available in size 14x51mm.
- It is type gG HPC (High Breaking Capacity).
- It is not equipped with light indicator.

This fuse meets the criteria of the **NF/EN/IEC 60269-1**, **NF HD/IEC 60269-2**, **NF C 60200-1** and **NF C 60200-2** standards.



Type 22x58

Description

- This fuse cartridge is available in size 22x58mm.
- It is type gG HPC (High Breaking Capacity).
- It is not equipped with light indicator.

This fuse meets the criteria of the **NF/EN/IEC 60269-1**, **NF HD/IEC 60269-2**, **NF C 60200-1** and **NF C 60200-2** standards.

Code	Designation	Voltage (V)	Breaking capacity (kA)	Weight (kg)	Sales unit
FUSE CARTRIDGE 10.3x38 gG					
U661-1	FUSE CARTRIDGE 10.3x38 1A	500	80	0.007	10
U661-2	FUSE CARTRIDGE 10.3x38 2A	500	80	0.007	10
U661-4	FUSE CARTRIDGE 10.3x38 4A	500	80	0.007	10
U661-6	FUSE CARTRIDGE 10.3x38 6A	500	80	0.007	10
U661-8	FUSE CARTRIDGE 10.3x38 8A	500	80	0.007	10
U661-10	FUSE CARTRIDGE 10.3x38 10A	500	80	0.007	10
U661-12	FUSE CARTRIDGE 10.3x38 12A	500	80	0.007	10
U661-16	FUSE CARTRIDGE 10.3x38 16A	500	80	0.007	10
U661-20	FUSE CARTRIDGE 10.3x38 20A	500	80	0.007	10
U661-25	FUSE CARTRIDGE 10.3x38 25A	500	80	0.007	10
U661-32	FUSE CARTRIDGE 10.3x38 32A	500	80	0.007	10
FUSE CARTRIDGE 14x51 gG					
U660-1	FUSE CARTRIDGE 14x51 gG 1A	690	80	0.021	10
U660-2	FUSE CARTRIDGE 14x51 gG 2A	690	80	0.021	10
U660-4	FUSE CARTRIDGE 14x51 gG 4A	690	80	0.021	10
U660-6	FUSE CARTRIDGE 14x51 gG 6A	690	80	0.021	10
U660-8	FUSE CARTRIDGE 14x51 gG 8A	690	80	0.021	10
U660-10	FUSE CARTRIDGE 14x51 gG 10A	690	80	0.021	10
U660-12	FUSE CARTRIDGE 14x51 gG 12A	690	80	0.021	10
U660-16	FUSE CARTRIDGE 14x51 gG 16A	690	80	0.021	10
U660-20	FUSE CARTRIDGE 14x51 gG 20A	690	80	0.021	10
U660-25	FUSE CARTRIDGE 14x51 gG 25A	690	80	0.021	10
U660-32	FUSE CARTRIDGE 14x51 gG 32A	500	80	0.021	10
U660-40	FUSE CARTRIDGE 14x51 gG 40A	500	80	0.021	10
U660-50	FUSE CARTRIDGE 14x51 gG 50A	400	80	0.021	10
FUSE CARTRIDGE 22x58 gG					
U640	FUSE CARTRIDGE 22x58 gG 2A	690	80	0.056	10
U641	FUSE CARTRIDGE 22x58 gG 4A	690	80	0.056	10
U642	FUSE CARTRIDGE 22x58 gG 6A	690	80	0.056	10
U643	FUSE CARTRIDGE 22x58 gG 8A	690	80	0.056	10
U644	FUSE CARTRIDGE 22x58 gG 10A	690	80	0.056	10
U645	FUSE CARTRIDGE 22x58 gG 12A	690	80	0.056	10
U646	FUSE CARTRIDGE 22x58 gG 16A	690	80	0.056	10
U647	FUSE CARTRIDGE 22x58 gG 20A	690	80	0.056	10
U648	FUSE CARTRIDGE 22x58 gG 25A	690	80	0.056	10
U649	FUSE CARTRIDGE 22x58 gG 32A	690	80	0.056	10
U650	FUSE CARTRIDGE 22x58 gG 40A	690	80	0.056	10
U651	FUSE CARTRIDGE 22x58 gG 50A	690	80	0.056	10
U652	FUSE CARTRIDGE 22x58 gG 63A	690	80	0.056	10
U653	FUSE CARTRIDGE 22x58 gG 80A	500	120	0.056	10
U654	FUSE CARTRIDGE 22x58 gG 100A	500	120	0.056	10
U655	FUSE CARTRIDGE 22x58 gG 125A	400	120	0.056	10

For other fuses, contact us.

Fuse cartridge AD

MIRELEC

Application

These AD fuse cartridges are used together with the circuit-breaker installed on the individual service tap connection. They perform the cutoff for high short-circuit currents and thereby extend the service life of the associated circuit-breaker, which is not overloaded up to the limit.



Cylindrical cartridge

Description

- This fuse cartridge is available in several sizes: 10.3x38, 14x51 and 22x58mm.
- Many models are available according to the circuit breaker nominal current to which it must be connected: AD 15A, AD 30A, AD 45A, AD 60A and AD 90A.
- Low power loss limits heating of the device holding the fuse and extends its service life.
- It is specified for a nominal voltage of 440V in alternating current with nominal frequency of 50Hz.
- The nominal breaking capacity is 20kA.

This fuse meets the criteria of the **HN62-S-83**, **NF/EN/IEC 60269-1**, **NF HD/IEC 60269-2**, **NF C 60200-1** and **NF C 60200-2** standards.

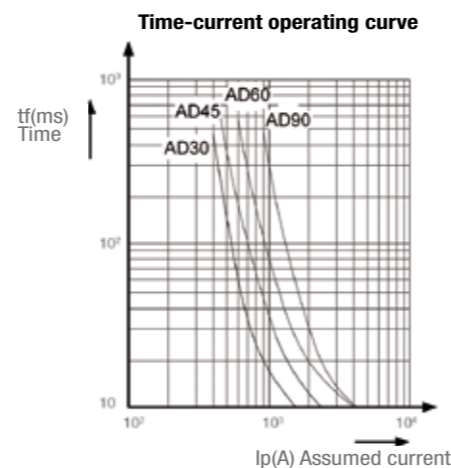

Code	Designation	Weight (kg)	Sales unit
FUSE CARTRIDGE 10.3x38mm			
U623	FUSE CARTRIDGE 10.3x38 AD 15A	0.009	10
U620	NEUTRAL TUBE 10.3x38	0.012	10
FUSE CARTRIDGE 14x51mm			
U615	FUSE CARTRIDGE 14x51 AD 15A	0.021	10
U616	FUSE CARTRIDGE 14x51 AD 30A	0.021	10
U617	FUSE CARTRIDGE 14x51 AD 45A	0.021	10
U621	NEUTRAL TUBE 14x51	0.016	10
FUSE CARTRIDGE 22x58mm			
U610	FUSE CARTRIDGE 22x58 AD 15A	0.056	10
U611	FUSE CARTRIDGE 22x58 AD 30A	0.056	10
U612	FUSE CARTRIDGE 22x58 AD 45A	0.056	10
U613	FUSE CARTRIDGE 22x58 AD 60A	0.056	10
U614	FUSE CARTRIDGE 22x58 AD 90A	0.056	10
U622	NEUTRAL TUBE 22x58	0.028	10

Note: Other 10.3x38, 14x51, 22x58 fuses can be supplied upon request: please contact us.



Fuse cartridge size 00

Description

- The size of this blade fuse cartridge is 00 according to the **IEC 60269-2-1** standard.
- There are 4 models available according to the nominal current of the circuit-breaker to which it must be connected: AD 30A, AD 45A, AD 60A and AD 90A.
- The fixing brackets are made of insulating synthetic materials.
- The accessible metal parts (screws), with the exception of the blades, are potential free and also have the degree of protection IP2X according to the **NF EN 60529** standard.
- Low power loss limits heating of the device holding the fuse and extends its service life.
- It is specified for a nominal voltage of 440V in alternating current with nominal frequency of 50Hz.
- The nominal breaking capacity is 20kA.

This fuse meets the criteria of the **HN62-S-83** standard.

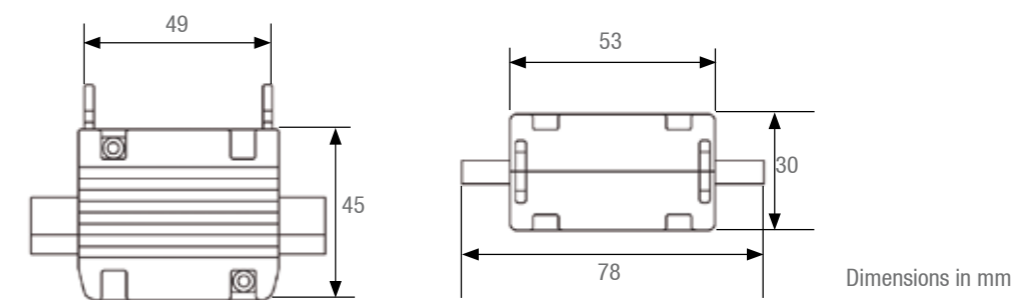

Code	Designation	Resistance to 20°C (μΩ)	Consumption (W)	Blade temperature rise (°K)	Weight (kg)	Sales unit
P241	FUSE CARTRIDGE SIZE 00 AD 30A	1150	1.4	9	0.150	10
P242	FUSE CARTRIDGE SIZE 00 AD 45A	740	2.1	16	0.150	10
P243	FUSE CARTRIDGE SIZE 00 AD 60A	650	3.3	20	0.150	10
P244	FUSE CARTRIDGE SIZE 00 AD 90A	430	5.1	34	0.150	10
P240	NEUTRAL BLADE CONTACT SIZE 00				0.060	10

Variant: Service connection protection with 100A maximum power

Code	Designation	Weight (kg)	Sales unit
P236	FUSE CARTRIDGE SIZE 00 100A	0.150	10

Accessory



The operating handle is used to install and extract fuses size 00 and size 2 in devices when these are not equipped with an integrated gripping system.

Code	Designation	Weight (kg)	Sales unit
P237	HANDLE FOR FUSES SIZE 00 - SIZE 2	0.260	1

Fuse cartridge NH1 and NH2

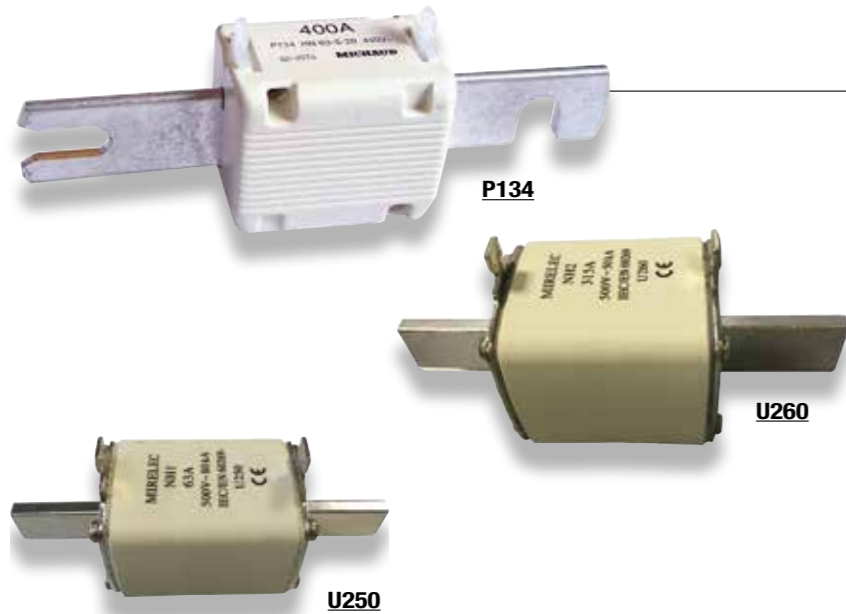

MIRELEC

Application

These low voltage fuses cartridges NH1 or NH2 are type gG. They are used as protection unit of the low voltage public electricity supply networks and works. It is installed in:

- Low voltage switchboards of the public electricity supply substations,
- Cutout boxes, inside or outside supply switches,
- Switch cabinets for subsurface networks,
- Metering boxes and cabinets for different uses.

Description

- The size of this blade fuse cartridge is NH1 or NH2 according to the **IEC 269-2-1** standard.
- It is available in several ratings:
 - 63A, 80A, 100A, 125A, 160A, 200A and 250A for NH1 115mm,
 - 125A, 200A, 250A, 315A and 400A for NH2 115mm,
 - 125A, 200A, 250A and 400A for NH2 160mm.
- It is specified for a nominal voltage of 440V in alternating current with nominal frequency of 50Hz.
- The nominal breaking capacity is 50kA minimum.

Fuse cartridge NH1 115mm

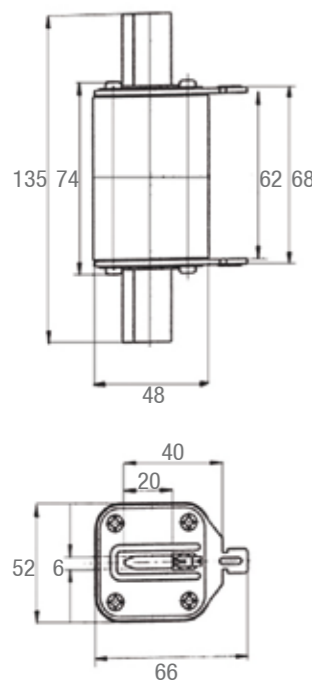

Fuse cartridge NH2 115mm

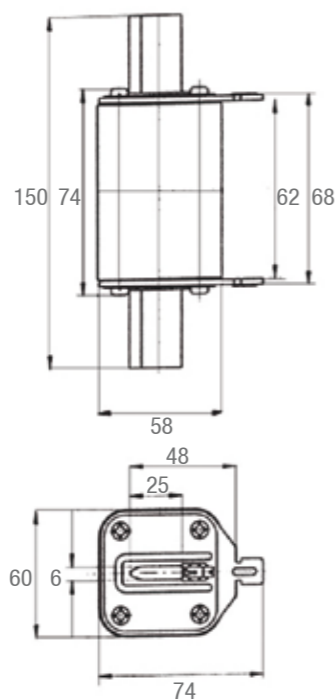

Fuse cartridge NH2 160mm

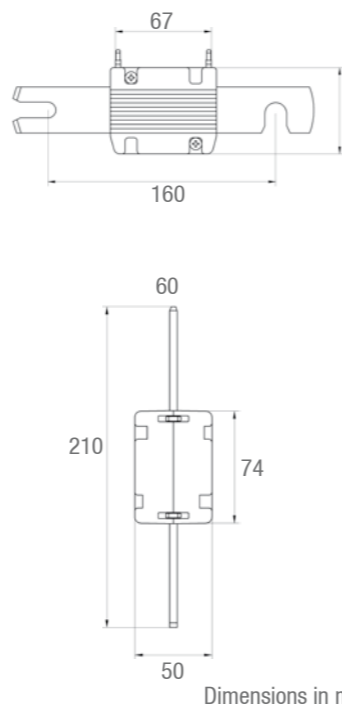

Dimensions in mm

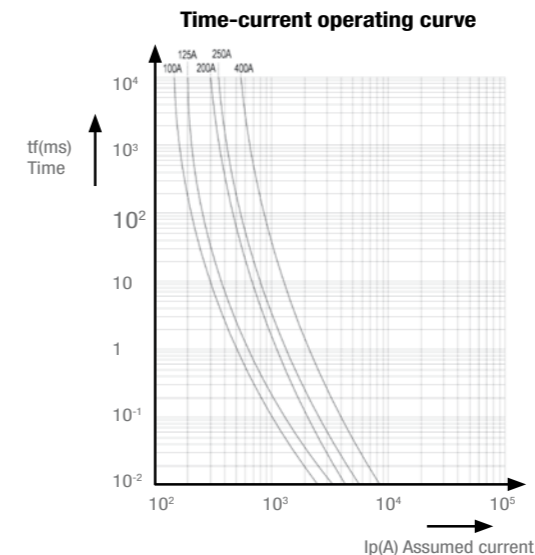

Code	Designation	Weight (kg)	Sales unit
FUSE CARTRIDGE NH1 AND NH2 115mm			
U250	FUSE CARTRIDGE NH1 63A 115mm	0.400	3
U251	FUSE CARTRIDGE NH1 80A 115mm	0.400	3
U252	FUSE CARTRIDGE NH1 100A 115mm	0.400	3
U253	FUSE CARTRIDGE NH1 125A 115mm	0.400	3
U254	FUSE CARTRIDGE NH1 160A 115mm	0.400	3
U255	FUSE CARTRIDGE NH1 200A 115mm	0.400	3
U256	FUSE CARTRIDGE NH1 250A 115mm	0.400	3
U257	FUSE CARTRIDGE NH2 125A 115mm	0.650	3
U258	FUSE CARTRIDGE NH2 200A 115mm	0.650	3
U259	FUSE CARTRIDGE NH2 250A 115mm	0.650	3
U260	FUSE CARTRIDGE NH2 315A 115mm	0.650	3
U261	FUSE CARTRIDGE NH2 400A 115mm	0.650	3
P238	NEUTRAL BLADE CONTACT NH2 115mm	0.210	1
FUSE CARTRIDGE NH2 160mm			
P130	FUSE CARTRIDGE NH2 125A 160mm	0.780	3
P131	FUSE CARTRIDGE NH2 200A 160mm	0.780	3
P132	FUSE CARTRIDGE NH2 250A 160mm	0.780	3
P134	FUSE CARTRIDGE NH2 400A 160mm	0.780	3
P239	NEUTRAL BLADE CONTACT NH2 160mm	0.290	1

Accessory



The operating handle is used to install and extract fuses size 00 and size 2 in devices when these are not equipped with an integrated gripping system.

Code	Designation	Weight (kg)	Sales unit
P237	HANDLE FOR FUSES SIZE 00 - SIZE 2	0.260	1

Earth system

Earth system

Earth electrodes

Copper bonded steel rod	p.124
Threaded copper bonded steel rod	p.126
Other earth electrodes	p.128
Copper earth plate and grid	p.130
Earth resistance measure - Earth tester	p.131

Earth connectors

Earth connector	p.132
Surge protection device connector	p.134
Insulation piercing connector for measure and short-circuiting	p.136

Earth conductors

Earth system and short-circuiting device	p.138
Switch earth system and short-circuiting device for Gang FSD	p.140
Cable	p.142
Tape	p.143
Aluminium earth cable and accessories	p.144



To meet electrical installations safety requirements, MICHAUD specialised in the **earth system field**.



The earth system

The role of an electrical installation earth system is to enable the fault current runoff into the soil. When an installation is damaged owing to an insulation fault, the current cannot flow correctly anymore. An electric shock occurs, that is to say an element is charging in electricity. At this stage, the current is trying to come out thanks to a conductive environment. This is the aim of the earth system.

Earth system main functions



People protection and safety

The earth system enables to **protect from the electrocution risk**. It limits the potential difference in the close environment in order to avoid contact or step voltage.



High frequency currents dispersal

The earth system also has to **discharge direct or indirect currents** coming from lightning shocks.



Goods and equipment protection

It **prevents goods and electrical installations from degradation**. The earth system ensures the electrical continuity and avoids too important voltage to installations terminals.

Components of an earth terminal

The electrical installation earth system is made by an earth terminal or earth circuit. The earth terminal connects the installation and the soil in which the fault current will be able to flow.

The earth terminal consists of three main components:

Connector
Enables connection

Conductor
Discharges current

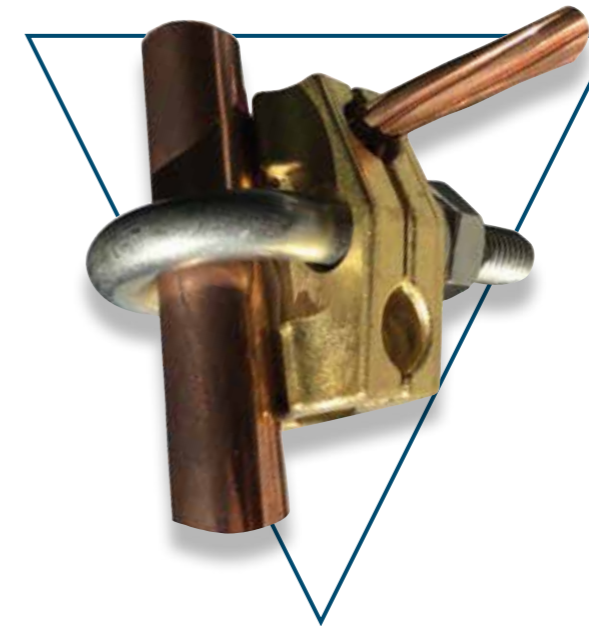

Electrode
Establishes contact with the soil

The electrode establishes a contact with the soil. It is therefore essential to study the soil in order to better adapt the installation.

Soil study

Earth resistance

The current runoff into the soil will meet the earth terminal resistance. This one is partly the consequence of the soil's resistivity itself.

The soil's resistivity depends on several elements:

- Ground nature
- Water content (humidity)
- Soil heterogeneity
- Climatic variations

A stable and wet ground will enable a better electrical conductivity and earth system effectiveness.

Soil resistivity

The soil electrical resistivity (ρ) is its capacity to limit the electrical current passage, it is expressed in ohm meter (Ωm).

Ground nature	Resistivity ρ (Ωm).
Marshy ground	10
Clay	8 to 50
Clay, sand and gravel	40 to 250
Sand and gravel	60 to 100
Slate, clay and sandstone	10 to 500
Rock	200 to 10 000



Earth electrode

The earth electrode has to establish a connection with the soil to allow the current runoff. It must guarantee a good conductivity and be adapted to the ground nature.

Deep earth terminal

It is recommended to go deep to find the weakest and the more stable earth resistance. Top layers are submitted to climatic variations so using an electrode able to go deep guarantees to meet stable and homogeneous soil.

Surface earth terminal

When it is not possible to go deep because of the soil nature or the risk of underground network degradation (gas, water, telecoms, etc...), an electrode on the surface turns out to be the best alternative.



The diversity of technics specifications used for earth systems gives the opportunity to find the best solution for every project.

Rod nature	Conductivity	Service life	Corrosion resistance	Competitiveness	Mechanical resistance
Copper bonded steel	+++	++	++	++	++
Stainless steel	+	+++	+++	+	++
Galvanised steel	++	+	+	+++	++

Earth conductor

The conductor is designed to disseminate the fault current from the equipment or the electrical installation up to the electrode. Two kind of conductors are available: round or cabled conductors and flat conductors or tapes.

Copper conductors

Cables remain the most common technology used in earth systems. For a specific installation or desired properties, tapes offer an alternative to cables (mechanical resistance).

Flat conductors

Copper conductors are generally recommended in earth circuits. Other metallic combinations can bring solutions to existing issues in the field.

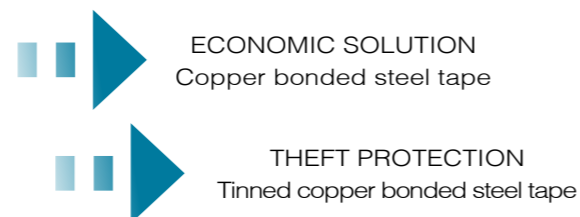

Connectors

Connectors must ensure a mechanical bonding between the different elements constituting the earth system to guarantee a good electrical continuity.

Connection conductor/electrode

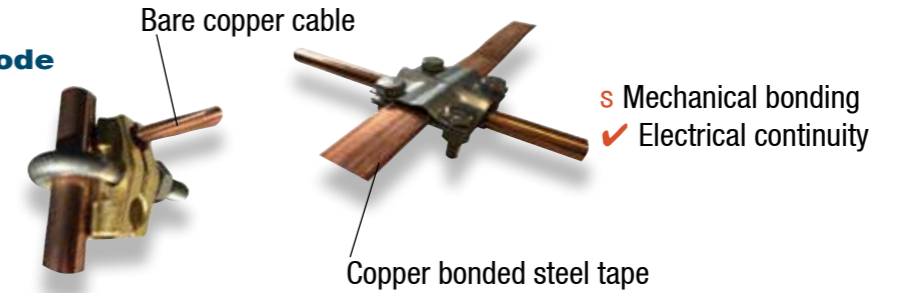

Connection conductor/conductor

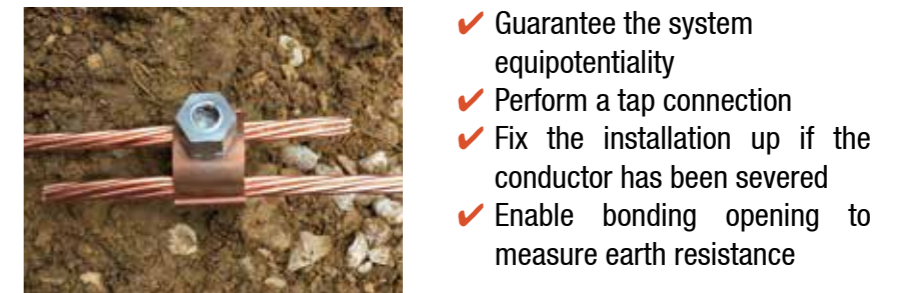

Connection A.B.C. conductor/connector

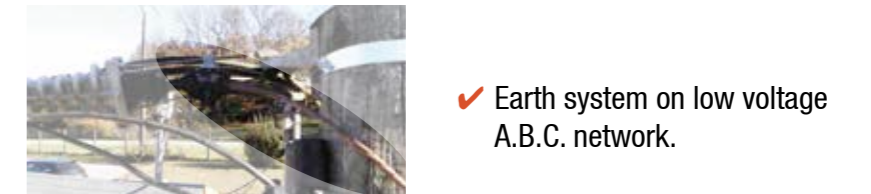

Galvanic corrosion phenomenon

A galvanic phenomenon can happen when two metals with different potential are in contact within a conductive solution (such as water). Electron transfer is run from an anode to a cathode leading to a quick degradation of the less noble metal (the anode).

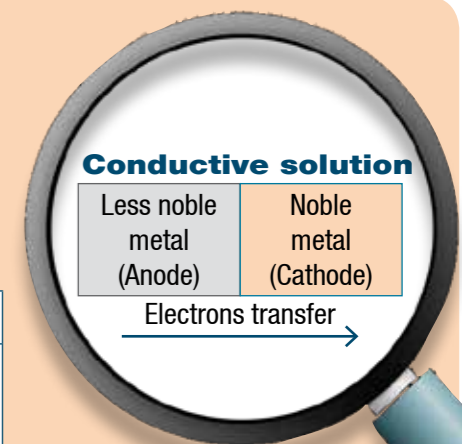

Electrode/connector combinations allowed	Connector (clamp)		
	Brass	Galvanised steel	Stainless steel
Electrode			
Copper bonded steel	✓	✗	✓
Stainless steel	✓	✗	✓
Galvanised steel	✗	✓	✓

All combinations are allowed with a copper conductor.

- ✓ Allowed
- ✓ Tolerated
- ✗ Not allowed



Installation

Tools and accessories

Some tools and accessories can be useful during the earth terminal installation.

Earth rod pushing

For a short rod installation into a wet soil, a hammer can enable pushing into ground.

For rods with more important dimensions, a drill hammer can be used.

Material protection

To protect the rod's copper coat during set up protection, accessories can be placed on both rod ends.

During the rod installation, abrasive elements in the soil can damage the copper coat. On the superior end, hammer blows can lead to copper and rod degradation. A driving spike and a driving head enable to prevent these aggressive effects.



Diverse recommendations



For an effective and reliable earth system:

- ✓ Insulate connections
- ✓ Watch connections locating them in a pit
- ✓ Control regularly the installation and the possible metal corrosion
- ✓ Perform the installation far from buried walls, deep foundations and rivers
- ✓ Do not use water distribution pipes
- ✓ Opt for a substantial depth to reach a stable resistance in a ground not submitted to climatic variations
- ✓ Ensure the system equipotentiality

Earth resistance measure

Preparation and material

The earth resistance measure is performed by an earth tester. In order to allow measurements, the earth circuit can be opened at the cutting blades or at the earth system disconnection kit.



Earth tester

The resistance value to get varies according to normative standards and installations types. The measure should be repeated over some time as the value might change due to a season, measure conditions or soils evolution.



Earth disconnection kit to unbolt

The resistance measurement through the 3 rods method

The measure

The 3 rods method also called 62% method is a way to measure the earth resistance. The measure consists of injecting a current between a first electrode and the earth rod to check. A third rod enables to measure voltage. Thanks to the ohm's law, it is possible to deduce the earth resistance.

Principle

This method implies to use 3 earth rods. One of them (P1) is that staying in the ground after the installation test. The rod (P2) must be placed in more than 10 meters from (P1) and third rod (P3) 62% of the separation distance of (P1) and (P2) in order to be out of the (P1) and (P2) influence area.

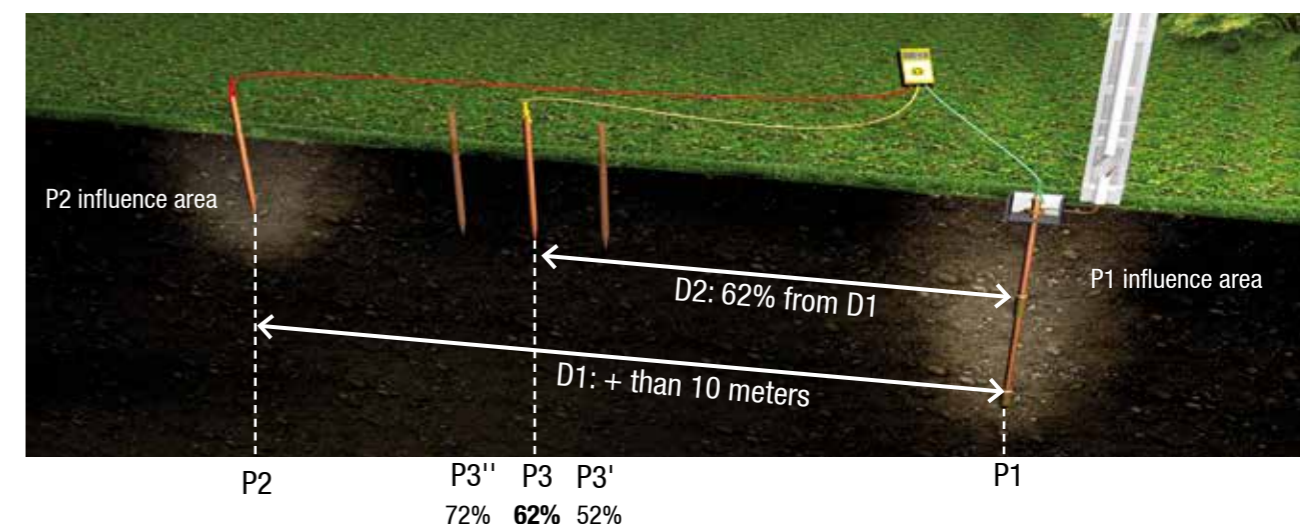

1st case:

The measure is not conclusive, the earth resistance value is too high. The rod must be extended or earth terminals must be multiplied taking care of the system equipotentiality in order to decrease value.

2nd case:

The measure is conclusive and it has to be confirmed. (P3) is going to be moved to 52% then to 72% from D1 respectively in P3' and P3''. If the measure does not vary, the value got in the first place is confirmed otherwise please refer to first case.

Copper bonded steel rod



F249

MIRELEC

Application

This earth rod is used for the power networks earth system. The copper coating made by electrolytic process gives a resistance to corrosion as well as a good conductivity. The reference Standard is **EN 50 164-2**.

Code	Designation	Nominal diameter (mm)	Real diameter (mm)	Length (m)	Weight (kg)	Sales unit
50µm COPPER COATING						
U203	EARTH ROD COPPER 50µm L = 1m DIAM 12.7	14	12.7	1	1.025	10
U204	EARTH ROD COPPER 50µm L = 1.5m DIAM 12.7	14	12.7	1.5	1.537	10
U205	EARTH ROD COPPER 50µm L = 2m DIAM 12.7	14	12.7	2	2.050	10
F226	EARTH ROD COPPER 50µm L = 1m DIAM 14	16	14	1	1.250	10
F244	EARTH ROD COPPER 50µm L = 1.5m DIAM 14	16	14	1.5	1.900	10
F245	EARTH ROD COPPER 50µm L = 2m DIAM 14	16	14	2	2.500	10
254µm COPPER COATING						
U206	EARTH ROD COPPER 254µm L = 1m DIAM 14	16	14	1	1.250	10
F249	EARTH ROD COPPER 254µm L = 1.5m DIAM 14	16	14	1.5	1.900	10
F227	EARTH ROD COPPER 254µm L = 2m DIAM 14	16	14	2	2.500	10
U207	EARTH ROD COPPER 254µm L = 3m DIAM 14	16	14	3	3.700	10
U208	EARTH ROD COPPER 254µm L = 1m DIAM 17.2	19	17.2	1	2.000	10
U209	EARTH ROD COPPER 254µm L = 1.5m DIAM 17.2	19	17.2	1.5	3.000	10
U210	EARTH ROD COPPER 254µm L = 2m DIAM 17.2	19	17.2	2	4.000	10
U211	EARTH ROD COPPER 254µm L = 3m DIAM 17.2	19	17.2	3	6.000	10
350µm COPPER COATING						
U212	EARTH ROD COPPER 350µm L = 1m DIAM 17.2	19	17.2	1	2.000	10
U213	EARTH ROD COPPER 350µm L = 1.5m DIAM 17.2	19	17.2	1.5	3.000	10
U214	EARTH ROD COPPER 350µm L = 2m DIAM 17.2	19	17.2	2	4.000	10

Nota: Other dimensions are available, please enquire.

Clamp



Connection clamp
F234

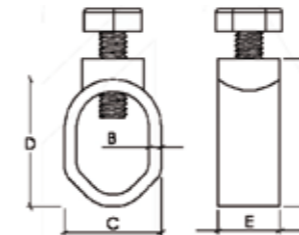

"U" bolt connection clamp
F224

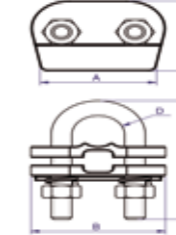

MIRELEC

Application

This **brass clamp with stainless steel bolts** is designed to establish a connection between the earth rod and the conductor. The cable can be fixed radially or axially through the "U" bolt clamp.

Code	Designation	Nominal rod diameter (mm)	Conductors sections (mm ²)	Dimensions (mm)					Screw	Weight (kg)	Sales unit
				A	B	C	D	E			
F234	CONNECTION CLAMP ROD DIAM 12.7 + 14 UNTHREADED	14 - 16	35	35	3	21	30	17.5	M8	0.050	10
F246	CONNECTION CLAMP ROD DIAM 17.2 UNTHREADED	19	50	38	3	23	32	17.5	M8	0.050	10
F233	"U" BOLT CONNECTION CLAMP 50 ² ROD DIAM 12.7 + 14 UNTHREADED	14 - 16	16 - 50	25	41	26	8.7	-	-	0.095	10
F224	"U" BOLT CONNECTION CLAMP 150 ² ROD DIAM 12.7 TO 17.2 UNTHREADED	14 to 19	150	44	52	38	10.2	64	-	0.230	25

Accessory



F229



F238

Application

These **brass driving spikes and heads** are designed to protect the earth rod during the installation. They enable to preserve the copper coating and its technical features.

Code	Designation	Nominal rod diameter (mm)	Weight (kg)	Sales unit
F229	DRIVING SPIKE FOR ROD DIAM 12.7 + 14 UNTHREADED	14-16	0.115	10
F239	DRIVING SPIKE FOR ROD DIAM 17.2 UNTHREADED	19	0.145	10
F238	DRIVING HEAD FOR ROD DIAM 12.7 + 14 UNTHREADED	14-16	0.115	10
F237	DRIVING HEAD FOR ROD DIAM 17.2 UNTHREADED	19	0.145	10

Threaded copper bonded steel rod



F262

MIRELEC

Application

This earth rod is used for the power networks earth system. The thread on both ends makes the earth rod lengthening possible. The copper coating made by electrolytic process gives a resistance to corrosion as well as a good conductivity. The reference Standard is **EN 50 164-2**.

Code	Designation	Nominal diameter (mm)	Real diameter (mm)	Length (m)	Weight (kg)	Sales unit
50µm COPPER COATING						
U215	EARTH ROD COPPER 50µm L = 1m DIAM 12.7 - 2 THREADS 9/16"	14	12.7	1	1.025	10
F296	EARTH ROD COPPER 50µm L = 1.5m DIAM 12.7 - 2 THREADS 9/16"	14	12.7	1.5	1.537	10
U216	EARTH ROD COPPER 50µm L = 2m DIAM 12.7 - 2 THREADS 9/16"	14	12.7	2	2.050	10
U217	EARTH ROD COPPER 50µm L = 1m DIAM 14 - 2 THREADS 5/8"	16	14	1	1.250	10
F235	EARTH ROD COPPER 50µm L = 1.5m DIAM 14 - 2 THREADS 5/8"	16	14	1.5	1.900	10
F223	EARTH ROD COPPER 50µm L = 2m DIAM 14 - 2 THREADS 5/8"	16	14	2	2.500	10
254µm COPPER COATING						
U218	EARTH ROD COPPER 254µm L = 1m DIAM 14 - 2 THREADS 5/8"	16	14	1	1.250	10
F222	EARTH ROD COPPER 254µm L = 1.5m DIAM 14 - 2 THREADS 5/8"	16	14	1.5	1.900	10
F221	EARTH ROD COPPER 254µm L = 2m DIAM 14 - 2 THREADS 5/8"	16	14	2	2.500	10
U219	EARTH ROD COPPER 254µm L = 3m DIAM 14 - 2 THREADS 5/8"	16	14	3	3.700	10
U220	EARTH ROD COPPER 254µm L = 1m DIAM 17.2 - 2 THREADS 3/4"	19	17.2	1	2.000	10
F262	EARTH ROD COPPER 254µm L = 1.5m DIAM 17.2 - 2 THREADS 3/4"	19	17.2	1.5	3.000	10
U221	EARTH ROD COPPER 254µm L = 2m DIAM 17.2 - 2 THREADS 3/4"	19	17.2	2	4.000	10
U222	EARTH ROD COPPER 254µm L = 3m DIAM 17.2 - 2 THREADS 3/4"	19	17.2	3	6.000	10
350µm COPPER COATING						
U223	EARTH ROD COPPER 350µm L = 1m DIAM 17.2 - 2 THREADS 3/4"	19	17.2	1	2.000	10
U224	EARTH ROD COPPER 350µm L = 1.5m DIAM 17.2 - 2 THREADS 3/4"	19	17.2	1.5	3.000	10
U225	EARTH ROD COPPER 350µm L = 2m DIAM 17.2 - 2 THREADS 3/4"	19	17.2	2	4.000	10

Nota: Other dimensions are available, please enquire.

Clamp



Connection clamp
F234



"U" bolt connection clamp
F224

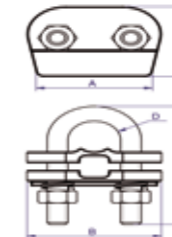
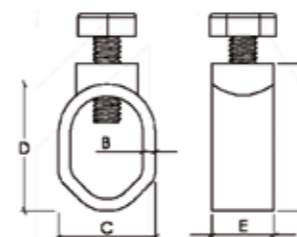

Code	Designation	Nominal rod diameter (mm)	Conductors sections (mm ²)	Dimensions (mm)					Screw	Weight (kg)	Sales unit
				A	B	C	D	E			
F234	CONNECTION CLAMP ROD DIAM 12.7 THREADED	14	35	35	3	21	30	17.5	M8	0.050	10
F246	CONNECTION CLAMP ROD DIAM 14 + 17.2 THREADED	16 - 19	50	38	3	23	32	17.5	M8	0.050	10
F233	"U" BOLT CONNECTION CLAMP 50 ² ROD DIAM 12.7 + 14 THREADED	14 - 16	16 - 50	25	41	26	8.7	-	-	0.095	10
F224	"U" BOLT CONNECTION CLAMP 150 ² ROD DIAM 12.7 TO 17.2 THREADED	14 to 19	150	44	52	38	10.2	64	-	0.230	25

MIRELEC

Application

This **brass clamp with stainless steel bolts** is designed to establish a connection between the earth rod and the conductor. The cable can be fixed radially or axially through the "U" bolt clamp.

Accessory



F229



F238



F228



F298

Application

These **brass driving spikes and heads** are designed to protect the earth rod during the installation. They enable to preserve the copper coating and its technical features.

These **brass threaded couplings** enable to join two rods and get a deeper earth system.

Code	Designation	Nominal rod diameter (mm)	Weight (kg)	Sales unit
F229	DRIVING SPIKE FOR ROD DIAM 12.7 THREADED	14	0.115	10
F239	DRIVING SPIKE FOR ROD DIAM 14 THREADED	16	0.145	10
U226	DRIVING SPIKE FOR ROD DIAM 17.2 THREADED	19	0.155	10
F238	DRIVING HEAD FOR ROD DIAM 12.7 THREADED	14	0.115	10
F237	DRIVING HEAD FOR ROD DIAM 14 THREADED	16	0.145	10
U227	DRIVING HEAD FOR ROD DIAM 17.2 THREADED	19	0.155	10
F298	THREADED COUPLING FOR ROD DIAM 12.7 THREAD 9/16"	14	0.090	10
F236	THREADED COUPLING FOR ROD DIAM 14 THREAD 5/8"	16	0.115	25
F265	THREADED COUPLING FOR ROD DIAM 17.2 THREAD 3/4"	19	0.155	10
U228	SCREW FOR COUPLING FOR ROD DIAM 12.7 THREAD 9/16"	14	0.085	10
F228	SCREW FOR COUPLING FOR ROD DIAM 14 THREAD 5/8"	16	0.100	25
U229	SCREW FOR COUPLING FOR ROD DIAM 17.2 THREAD 3/4"	19	0.135	10

Other earth electrode

Galvanised steel rod



Solid profile U195



Tubular profile U199

MIRELEC

Application

This galvanised steel earth rod is used for the power networks earth system. The corrosion protection is ensured thanks to a hot dip galvanisation surface treatment.

The reference Standard is **EN 50 164-2**.

Code	Designation	Diameter (mm)	Profile	Length (m)	Weight (kg)	Sales unit
U195	EARTH ROD GALVA L = 1m DIAM 16	16	Solid	1	1.70	10
U196	EARTH ROD GALVA L = 1.5m DIAM 16	16	Solid	1.5	2.55	10
U197	EARTH ROD GALVA L = 2m DIAM 16	16	Solid	2	3.40	10
U198	EARTH ROD GALVA L = 1.5m DIM 50x50x3	50x50x3	Cross-shaped	1.5	2.10	10
U199	EARTH ROD GALVA L = 1m DIAM 25	25	Tubular	1	1.60	10
U200	EARTH ROD GALVA L = 1.5m DIAM 25	25	Tubular	1.5	2.40	10
U201	EARTH ROD GALVA L = 2m DIAM 25	25	Tubular	2	3.20	10

Nota: Other dimensions are available, please enquire

Clamp



U192

Application

This clamp dedicated to galvanised earth rods is designed to establish a connection between the earth rod and the conductor.

Code	Designation	Rod diameter (mm)	Metal	Conductors section (mm ²)	Weight (kg)	Sales unit
U191	CONNECTION CLAMP GALVA ROD DIAM 16	16	Galvanised steel	50mm ²	0.054	20
U192	CONNECTION BOLT AND NUT ROD CROSS-SHAPED		Zamac / nickel	50mm ²	0.072	100
U193	CONNECTION CLAMP 25mm ² ZINC BRASS ROD CROSS-SHAPED		Zinc brass	25mm ²	0.032	20
U194	CONNECTION CLAMP 50mm ² ZINC BRASS ROD CROSS-SHAPED		Zinc brass	50mm ²	0.077	20

The connection between the conductor and the tubular earth rod is made by the actual ear on the top end of the rod. It receives a bolt and nut as well as a tubular lug.

Bolt and nut, please enquire.

SEE SHEET
OVERHEAD / LV ending fitting / Bare lug

Stainless steel earth rod

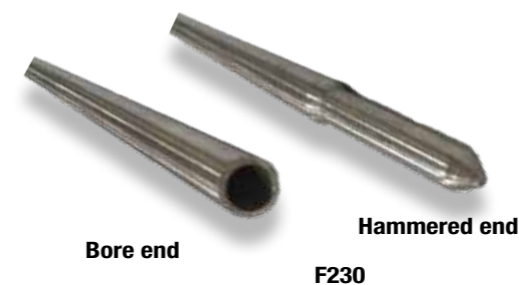

Bore end

Hammered end

F230

MIRELEC

Application

This stainless steel earth rod is used for the power networks earth system. It gives a huge resistance to corrosion and can be implemented into hard grounds.

The rod has a hammered end and a boring respectively to lower and upper ends, giving it the possibility to be self-extendable.

The reference Standard is **EN 50 164-2**.

Code	Designation	Diameter (mm)	Length (m)	Weight (kg)	Sales unit
F230	EARTH ROD STAINLESS STEEL SELF-EXTENDABLE L = 1m DIAM 16	16	1	1.50	10
F231	EARTH ROD STAINLESS STEEL SELF-EXTENDABLE L = 1.5m DIAM 16	16	1.5	2.30	10
F232	EARTH ROD STAINLESS STEEL SELF-EXTENDABLE L = 2m DIAM 16	16	2	3.20	10

Nota: Other dimensions are available, please enquire.

Clamp



Connection clamp F234



"U" bolt connection clamp F224

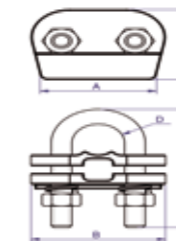
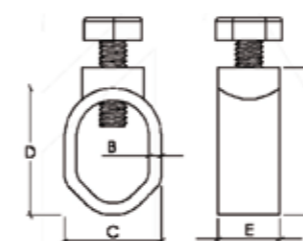

Application

This **brass clamp with stainless steel bolts** is designed to establish a connection between the stainless steel earth rod and the conductor. The cable can be fixed radially or axially through the "U" bolt clamp.

Code	Designation	Rod diameter (mm)	Conductors sections (mm ²)	Dimensions (mm)					Screw	Weight (kg)	Sales unit
				A	B	C	D	E			
F234	CONNECTION CLAMP ROD STAINLESS STEEL	16	16-35	35	3	21	30	17.5	M8	0.050	10
F233	"U" BOLT CONNECTION CLAMP 50 ² ROD STAINLESS STEEL	16	16-50	25	41	26	8.7	-	-	0.095	10
F224	"U" BOLT CONNECTION CLAMP 150 ² ROD STAINLESS STEEL	16	70-150	44	52	38	10.2	64	-	0.230	25

Copper earth plate and grid



U188

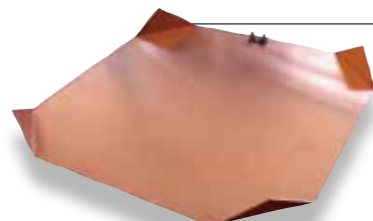

U184

MIRELEC

Application

This copper earth electrode is used for the power networks earth system. When a deep installation is not possible, it gives an important contact area with the soil to discharge fault currents. The reference Standard is **EN 50 164-2**.

Code	Designation	Length (mm)	Width (mm)	Thickness (mm)	Weight (kg)	Sales unit
U184	COPPER EARTH PLATE 500x500x2	500	500	2	4.5	1
U185	COPPER EARTH PLATE 500x500x3	500	500	3	6.8	1
U186	COPPER EARTH PLATE 500x1000x2	500	1000	2	9.0	1
U187	COPPER EARTH PLATE 500x1000x3	500	1000	3	13.6	1
U188	COPPER EARTH GRID 1000x1000x2	1000	1000	2	3.0	1
U189	COPPER EARTH GRID 2000x1000x2	2000	1000	2	4.0	1
U190	COPPER EARTH GRID 3000x1000x2	3000	1000	2	5.0	1

Clamp

Description

- Earth plates are delivered with a "U" bolt connection clamp enabling to perform the connection with the conductor.
- Earth grids can receive a "U" bolt connection clamp to perform the connection with the copper conductor.
- The earth grid connection can also be performed thanks to twin-saddle installed on the grid lateral tape.

If you need more informations, please contact us.

SEE SHEET
EARTH SYSTEM / Earth electrodes / Clamp

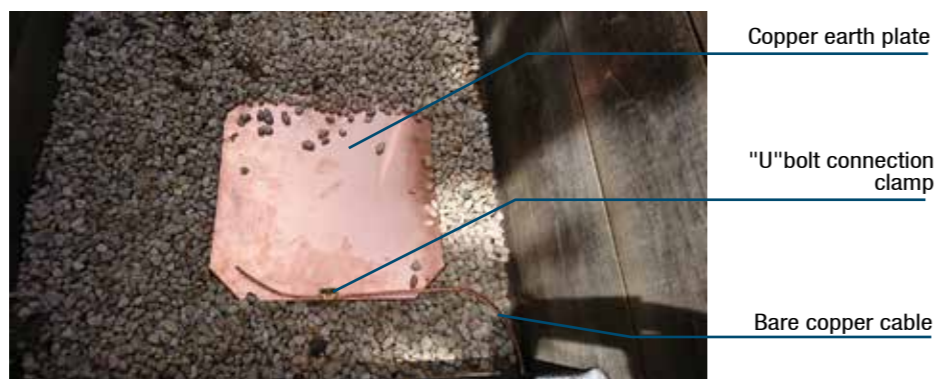

Copper earth plate

"U" bolt connection clamp

Bare copper cable

Earth resistance measure - Earth tester



F439

MIRELEC

Application

This earth tester is used as part of the earth system installation. It enables to perform the earth resistance measurements to control the system effectiveness.

Description

- This earth tester is installed in a anti-shock briefcase including three green, yellow and red cords respectively of 5m, 10m and 15m length.
- Cords are provided with a clamp to be placed on rod enabling the measure.
- The tester supply is possible thanks to batteries.
- The recommended surrounding temperature for use is between 0 and 40°C.
- The device is adapted to "2 rods" and "3 rods" measure methods. These methods require the use of backup rods. It is necessary to enable the current circulation between rods in order to perform an earth resistance measure thanks to the earth tester.
- The device keeps in memory the last measure.

The earth tester meets the criteria of **IEC 348** and **IEC 1010** standards.

Code	Designation	Measure range (Ω)	Measure current	Dimensions (mm)	Weight (kg)	Sales unit
F439	EARTH TESTER	0 to 2k	Constant 2mA @ 820Hz	205x90x55	0.550	1

Installation

Measure with the 3 rods method.

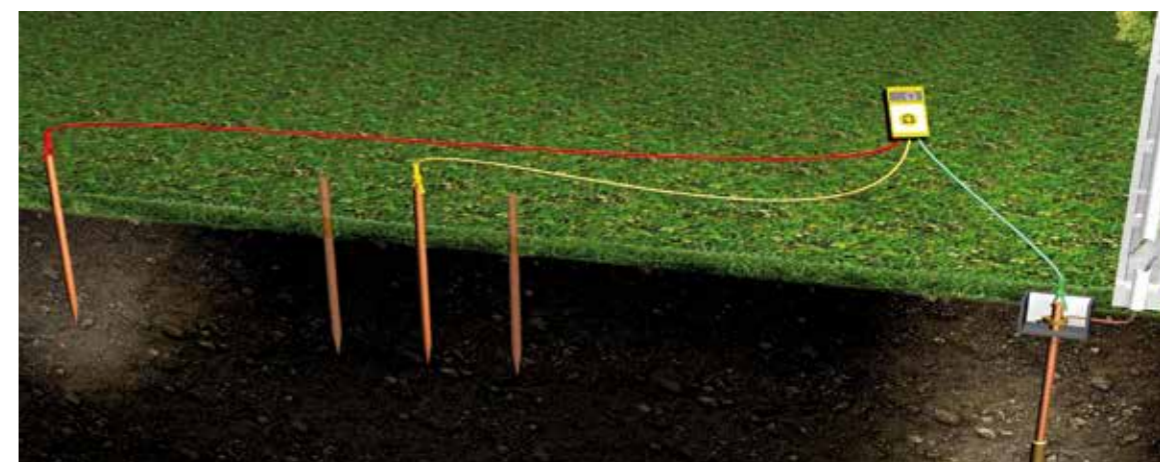

Earth connector

"C" shape connector



U009

MIRELEC

Application

This **copper connector** is designed to join conductors. The mechanical and electrical connection is ensured thanks to crimping.

Code	Designation	Main conductor (mm ²)	Tap conductor (mm ²)	Weight (kg)	Sales unit
U001	C CONNECTOR 4-4	2.5-4	2.5-4	0.010	10
U002	C CONNECTOR 10-6	6-10	2.5-6	0.010	10
U003	C CONNECTOR 25-6	10-25	4-6	0.012	10
U004	C CONNECTOR 25-10	16-25	4-10	0.012	10
U005	C CONNECTOR 25-25	16-25	16-25	0.017	10
U006	C CONNECTOR 35-25	35	4-25	0.017	10
U007	C CONNECTOR 35-35	35	16-35	0.034	10
U008	C CONNECTOR 70-35	50-70	4-35	0.034	10
U009	C CONNECTOR 70-70	50-70	35-70	0.034	10
U010	C CONNECTOR 95-35	70-95	16-35	0.072	10
U011	C CONNECTOR 95-70	70-95	35-70	0.072	10
U012	C CONNECTOR 95-95	95	95	0.131	10
U013	C CONNECTOR 120-120	120	25-120	0.109	10
U014	C CONNECTOR 185-95	150-185	50-95	0.109	10
U015	C CONNECTOR 150-150	150	70-150	0.109	10
U016	C CONNECTOR 185-185	120-185	95-185	0.131	10

Jumper clamp



U020

Application

This **connector made of brass** is designed to join conductors. The mechanical and electrical connection is ensured thanks to a mechanical tightening that can be removed.

Code	Designation	Main conductor (mm ²)	Tap conductor (mm ²)	Weight (kg)	Sales unit
U020	JUMPER CLAMP 6-16mm ²	6-16	6-16	0.028	10
U021	JUMPER CLAMP 10-50mm ²	10-50	10-50	0.061	10
U022	JUMPER CLAMP 50-70mm ²	50-70	50-70	0.112	10
U023	JUMPER CLAMP 70-95mm ²	70-95	70-95	0.263	10
U024	JUMPER CLAMP 95-150mm ²	95-150	95-150	0.443	10

Copper connector



L260

MIRELEC

Application

This **copper connector** is designed to fix up an installation in case the conductor has been severed. The **stainless steel fastening** allows the product to be buried. The connector L260 is equipped with a shear head.

Code	Designation	Main conductor (mm ²)	Tap conductor (mm ²)	Weight (kg)	Sales unit
L260	CONNECTOR Cu 10-70 (SF + SH)	10-70	10-70	0.120	50
L261	CONNECTOR Cu 10-70 (SF)	10-70	10-70	0.110	50

Earth system disconnection kit



U031

Application

This **stainless steel kit** comprises two tubular lugs as well as a nut and a bolt. It is designed to disconnect the earth system in order to perform earth resistance measurements.

Code	Designation	Conductor section min (mm ²)	Conductor section max (mm ²)	Weight (kg)	Sales unit
U030	TUBULAR LUG 25-29	25	29	0.020	10
U031	EARTH SYSTEM DISCONNECTION KIT 25-29	25	29	0.060	20

Ground cutting blade

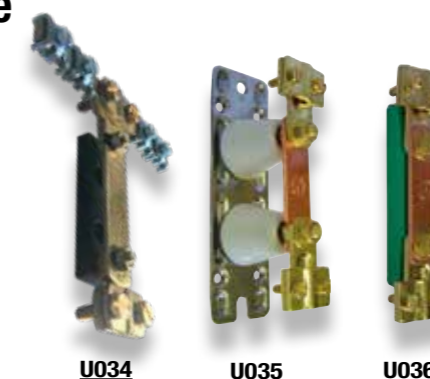

U034

U035

U036

Application

This cutting blade is designed to open the earth system during earth resistance measurements. It is rather used inside for a residential installation.

Code	Designation	Conductor section min (mm ²)	Conductor section max (mm ²)	Weight (kg)	Sales unit
U034	"T" SHAPE GROUND CUTTING BLADE	10	35	0.180	10
U035	HIGH GROUND CUTTING BLADE	16	35	0.3300	3
U036	LOW GROUND CUTTING BLADE	16	35	0.160	3

Surge protection device connector

MIRELEC

Application

The surge protection device connector (SPD IPC) is designed to protect low voltage overhead lines and electric equipment against over-voltages. It enables the current from the lightning to be led to the ground.

The surge protection device connector includes the following elements:

- An insulation piercing connector,
- A terminal outlet inserted in the end cap of the connector,
- A surge protection device (metal oxide overmoulded with silicone) screwed into the terminal outlet,
- An earth system tail welded to the surge protection device.

The surge protection device reacts:

- After a certain number of over-voltages, when the current passing through the surge protection device increases by more than 1mA,
- In the case of atmospheric discharge (lightning strike), the current exceeding 65mA.

After the surge protection device has performed, the earth system tail physically separates from the connector. The surge protection device then should be replaced with an available spare part (comprising the surge protection device and the earth system tail).



K241 -K 242

K243 - K244

Drawing of the connector

Description

- The connector is used outside only.
- The maximum use altitude is 2000m.
- The connector can be used at a temperature going from -40°C to +70°C.
- The use frequency is 48-62Hz.
- The connector, the terminal outlet, the surge protection device and the tail are made of UV and flame resistant materials.
- The connector is equipped with a 0.5m long, 6mm² insulated black multi-stranded tail.
- The connector protection degree is IP67.
- The connector has a response time <25ns.

The surge protection device is Class II as defined in the **IEC 61643-1** standard.

Installation

- The location of the surge protection device connection is decided according to the technical specifications and guidelines of the electrical regulatory authorities. These connectors must be installed on all overhead service and network line conductors, the phase(s) and neutral being linked by earth system tails.
- To protect long sections of overhead lines, it is recommended to use at least one surge protection device connector every 500 metres.
- Check that the terminal outlet is inserted into the connector fully and correctly.
- Position the connector on the conductor so that the surge protection device and its tail are directed towards the ground.
- Tighten the shear head until it breaks using a 13mm spanner. The 17mm head is only provided for an eventual dismantling. Do not use it to re-tighten.
- When the surge protection device connector has been used, protecting the power line against high voltages, the earth system tail is automatically disconnected from the base of the silicone cylinder. A new surge protection device, available as a spare part, must replace the old one. To do this, unscrew the old part of the silicone surge protection device from the terminal end and screw in a spare surge protection device, join all of the earth system tails together and link them to the earth.

Characteristics:

Code	Designation	I _{max} Maximal discharge current (kA)	U _c Continuous operating voltage V(AC)	I _n Nominal discharge current (kA)	U _p Protection level at In
K241	SPD IPC 15kA/275VAC 0.5m	40	275	15	< 1.86
K243	SPD SPARE PART 15kA/275VAC 0.5m	40	275	15	< 1.86
K242	SPD IPC 15kA/440VAC 0.5m	40	440	15	< 2.24
K244	SPD SPARE PART 15kA/440VAC 0.5m	40	440	15	< 2.24

Code	Designation	Main line insulated Al-Cu (mm ²)	Weight (kg)	Sales unit
K241	SPD IPC 15KA/275VAC 0.5m	16-95	0.300	30
K243	SPD SPARE PART 15KA/275VAC 0.5m		0.170	30
K242	SPD IPC 15KA/440VAC 0.5m	16-95	0.300	30
K244	SPD SPARE PART 15KA/440VAC 0.5m		0.170	30

Upon request, the earth system tails can be delivered in different colours and lengths, and can be assembled with a terminal lug at their end. Please contact us.

SEE SHEET
INSTALLATION / LV insulated toolings

Insulation piercing connector for measure and short-circuiting



Connector CMCC/CT

MICHAUD

Application

This I.P.C. (Insulation Piercing Connector) is designed for short-circuiting or earthing the low voltage A.B.C. (Aerial Bundled Conductors). It is also used for taking voltage measures. It comprises the connector and the socket.

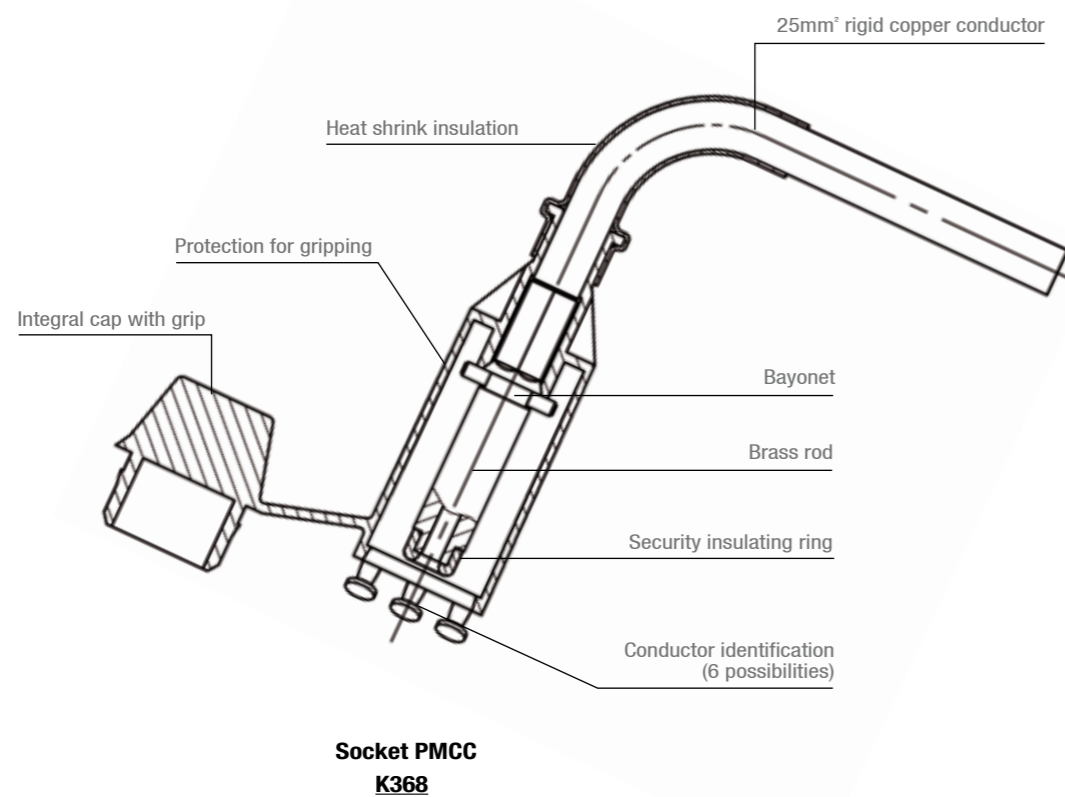

Socket PMCC
K368

Description

- Connection is established through the insulation piercing technology.
- Dielectric strength in water is greater than 6kV.
- Tightening screw is the only accessible metal part and is potential free.
- Tightening efficiency is ensured by shear head screw.
- The end socket is protected by an integral cap preventing the water penetration and corrosion.

This connector meets the criteria of the **NF C 33-020** and **EN 50-483** standards.

Code	Designation	Capacities Main insulated Al-Cu (mm ²)	Weight (kg)	Sales unit
VISSERIE ACIER ZINGUÉ (VZ)				
K362	CONNECTOR CMCC/CT 25 ZF	16-25	0.230	10
K363	CONNECTOR CMCC/CT 70 ZF	16-70	0.230	10
K361	CONNECTOR CMCC/CT 95 ZF	16-95	0.230	10
K364	CONNECTOR CMCC/CT 150 ZF	16-150	0.230	10

The connector K362 is adapted from a connector K322 (CBS/CT 25), the connector K363 from a connector K323 (CBS/CT 70) and the connector K364 from a connector K324 (CBS/CT 150). It comprises the connector and the socket.

Variant:

The short-circuiting and earth system socket (PMCC) can be sold separately. This tap socket can be used with the entire range of the 6kV CBS/CT and RDP/CN connectors of MICHAUD brand.

Code	Designation	Weight (kg)	Sales unit
K368	SHORT-CIRCUITING AND EARTH SYSTEM SOCKET (PMCC)	0.100	25

SEE SHEET
INSTALLATION / LV insulated toolings

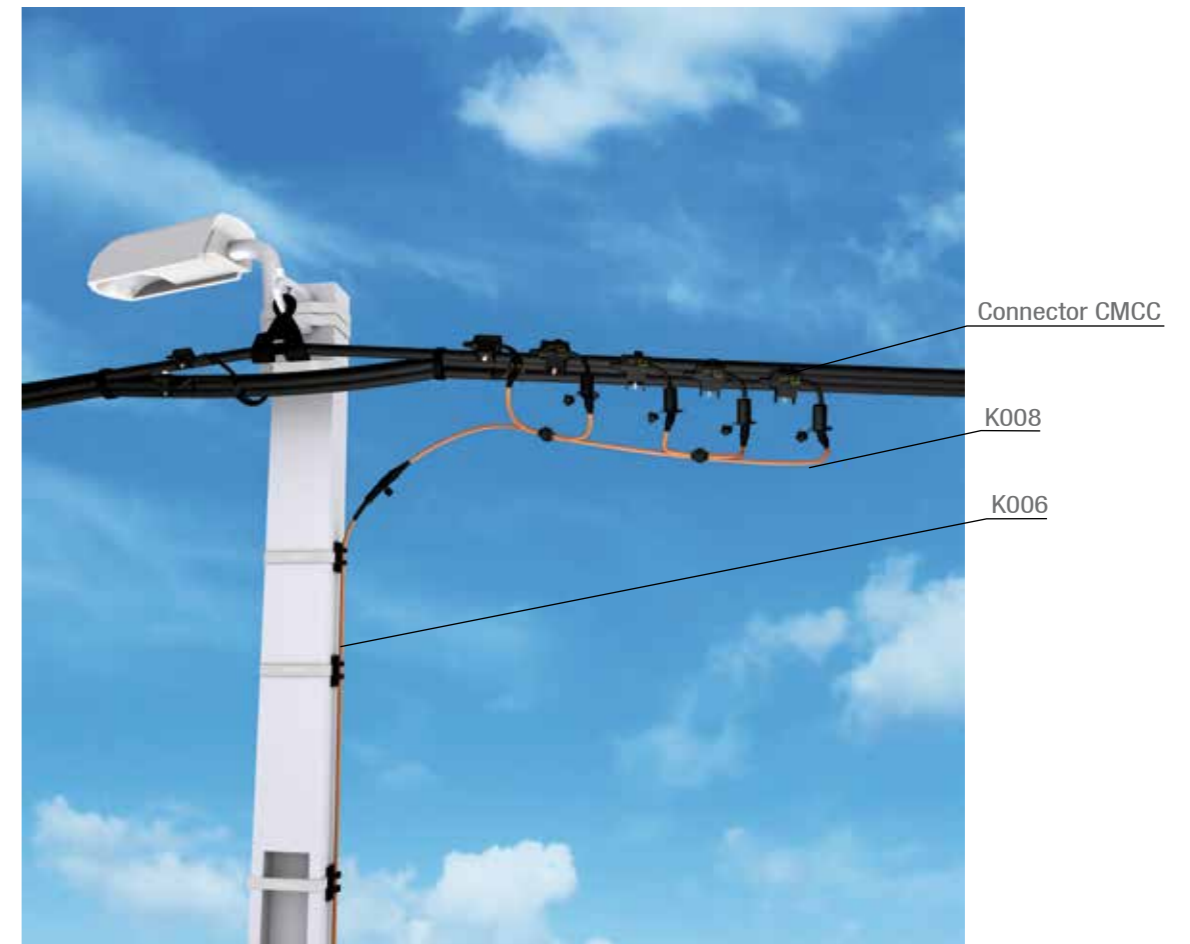

Earth system and short-circuiting device

Short-circuiting device



6 sockets
(K008)

MICHAUD

Application

This device is designed for short-circuiting and earthing the low voltage A.B.C. (Aerial Bundled Conductors). It is connected to a connector for measures and short-circuiting (type CMCC).

Description

- This device comprises 6 or 7 insulated sockets closing with a bayonet system on the CMCC connector tap socket.
- Connection between the sockets is established with a 25mm² flexible copper conductor.
- The electrical characteristics are:
 - Short-circuiting capacity: 4 000A during 1 second.
 - Permanent current capacity: 200A.
- The device is packed in a carrying case.

Code	Designation	Weight (kg)	Sales unit
K008	SHORT-CIRCUITING EQUIPMENT 6 SOCKETS	2.490	1
K009	SHORT-CIRCUITING EQUIPMENT 7 SOCKETS	3.000	1

Nota: the K009 (7 sockets) is used for street light.

Earth system equipment



K006

MICHAUD

Application

This equipment is used for earth system a low voltage A.B.C. (Aerial Bundled Conductor). It is connected on short-circuiting device linked to CMCC connectors (for measures and short-circuiting).

Description

- This equipment comprises the following elements:
 - Earth clamp,
 - 10m long 25mm² copper insulated flexible conductor,
 - Insulated socket closing with a bayonet system on CMCC connector tap socket.
- The electrical characteristics are:
 - Short-circuiting capacity : 4 000A during 1 second.
 - Permanent current capacity: 200A.
- The equipment is packed in a carrying case.

Code	Designation	Weight (kg)	Sales unit
K006	EARTH SYSTEM EQUIPMENT	4.000	1

Nota: the earth clamp has to be fixed on a rod. Contact us.

SEE SHEET
EARTH SYSTEM / Earth electrodes

Switch earth system and short-circuiting device for Gang FSD



K010

MICHAUD

Application

This device is designed for short-circuiting and earthing the low voltage A.B.C. (Aerial Bundled Conductor). It is connected to the MICHAUD 3-poles type pole-mounted Gang Fuse Switch Disconnecter (Gang FSD).

Description

- The short-circuiting of the Gang Fuse Switch Disconnecter poles is carried out using a tinned metal comb bar. This bar can be seen from the bottom of the pole which constitutes a visual indicator of the short-circuiting of the poles.
- A safety hook made of synthetic material ensures correct closing of the bar holder on the body of the Gang fuse switch disconnecter. The load related to the weight of the copper cable is offset towards the bar rotational axis via the presence of a metal bar. This assembly prevents the device from being opened when the operator pulls on the cable.
- A 2.5m long 35mm² copper cable with transparent insulation is fixed to the metal bar using a terminal lug. The other end of the cable is linked to the earth system clamp.
- The short-circuiting capacity is 9kA maximum over 500V.
- The device is delivered in a case ensuring safe transport and storage.

Installation

Fuse switch disconnecter earthing

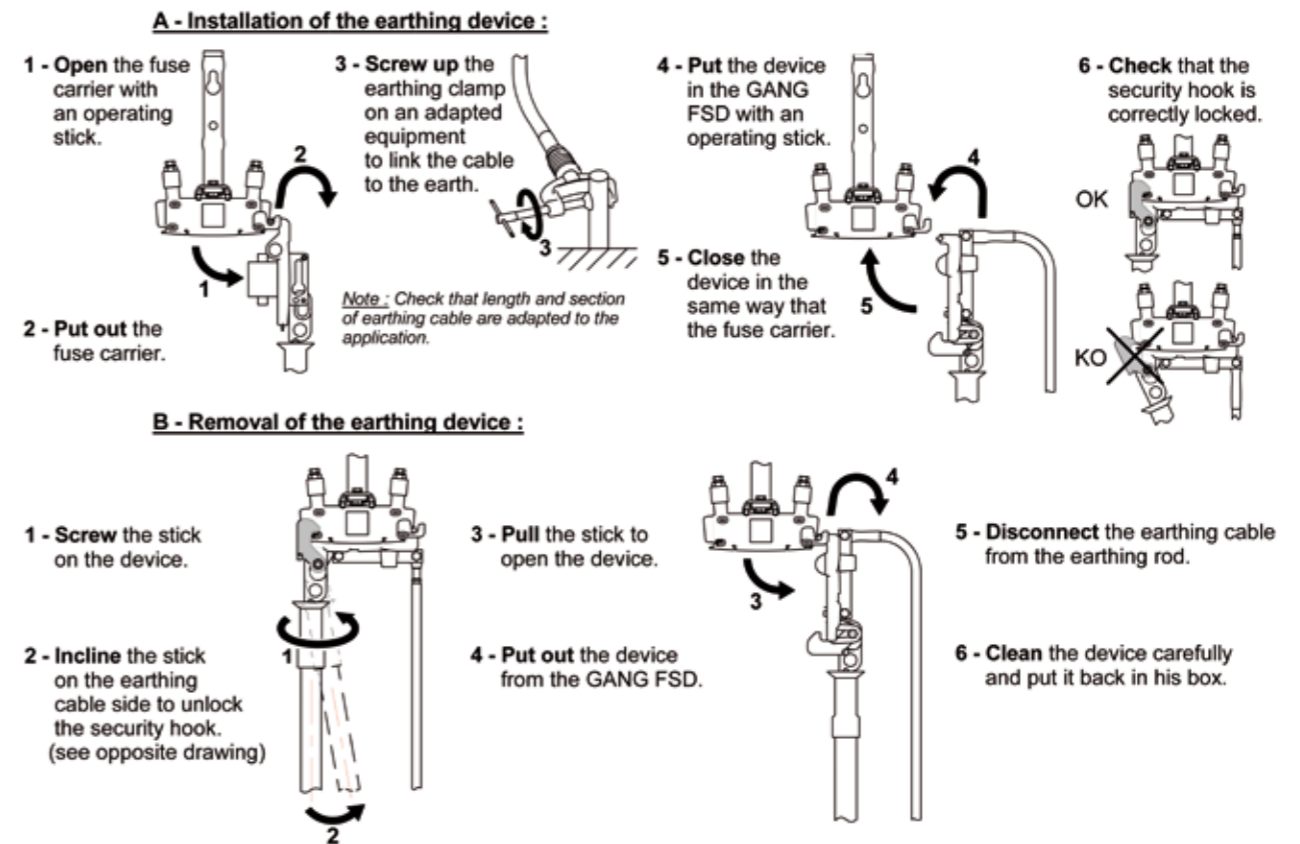

Replacement of the copper cable

The copper cable with transparent insulation and earth system clamp can be damaged during careless handling. Therefore, it should be replaced to ensure correct use of the device in complete safety. For this, dismantle the existing cable and replace it with a new MICHAUD model by screwing the terminal lug on the metal bar of the device.

Code	Designation	Weight (kg)	Sales unit
K010	GANG FSD EARTH SYSTEM DEVICE 3 POLES	2.500	1
K012	GANG FSD EARTH SYSTEM DEVICE COPPER CABLE (2.5m / 35mm ²)	1.400	1

SEE SHEET
PROTECTION / Network protection/ Fuse switch disconnecter triple pole 160A

Cable

Bare copper



U051

MIRELEC

Application

This cable is designed for the earth systems. It is resistant to a temperature range of -15°C / +70°C and its flame behaviour meets the criteria of **IEC 60332-1**.

Description

- Nominal voltage: 600/1000V
- Short-circuit temperature: +250°C
- Minimum bending radius:
 - From 10mm² up to 25mm² (3x external Ø)
 - From 29mm² up to 300mm² (6x external Ø)
- This cable meets the criteria of the **EN 60228** standard.

Code	Designation	Section (mm ²)	Number of strands	Strand diameter (mm)	External Ø (mm)	Weight (kg/km)	Sales unit
U050	BARE COPPER CABLE 10mm ² - 500m drum	10	7	1.31	4	85	1
U051	BARE COPPER CABLE 16mm ² - 500m drum	16	7	1.67	5.1	138	1
U052	BARE COPPER CABLE 25mm ² - 500m drum	25	7	2.09	6.3	216	1
U053	BARE COPPER CABLE 29mm ² - 500m drum	29	19	1.40	7	250	1
U054	BARE COPPER CABLE 35mm ² - 500m drum	35	7	2.48	7.5	304	1
U055	BARE COPPER CABLE 50mm ² - 500m drum	50	19	1.76	8.2	415	1
U056	BARE COPPER CABLE 70mm ² - 500m drum	70	19	2.13	9.8	608	1
U057	BARE COPPER CABLE 95mm ² - 500m drum	95	19	2.48	11.4	825	1
U058	BARE COPPER CABLE 120mm ² - 500m drum	120	37	2.01	12.8	1055	1
U059	BARE COPPER CABLE 150mm ² - 500m drum	150	37	2.21	14.4	1275	1
U060	BARE COPPER CABLE 185mm ² - 500m drum	185	37	2.48	16.2	1606	1
U061	BARE COPPER CABLE 240mm ² - 500m drum	240	37	2.84	18.8	2106	1
U062	BARE COPPER CABLE 300mm ² - 500m drum	300	61	2.48	21	2661	1

Insulated copper

U069

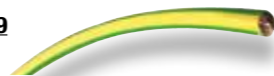

Description

- Nominal voltage: 450/750V
- Test voltage: 2500V
- Short circuit temperature: +150°C
- Minimum bending radius: 5x external Ø
- This copper cable is covered by a PVC insulation.
- This cable meets the criteria of the **EN 50525-2-3** standard.

Code	Designation	Section (mm ²) (Nb strands x strand Ø)	Insulation thickness (mm)	Conductor resistance at 20°C	External Ø (mm)	Weight (kg/km)	Sales unit
U063	INSULATED COPPER CABLE 6mm ² - 500m drum	6 (30x0.5)	1	3.30	5.3	63	1
U064	INSULATED COPPER CABLE 10mm ² - 500m drum	10 (7x1.34)	1	1.83	6,1	103	1
U065	INSULATED COPPER CABLE 16mm ² - 500m drum	16 (7x1.67)	1	1.15	7.01	164	1
U066	INSULATED COPPER CABLE 25mm ² - 500m drum	25 (7x2.09)	1.20	0.727	8.67	257	1
U068	INSULATED COPPER CABLE 35mm ² - 500m drum	35 (7x2.46)	1.20	0.524	9.78	347	1
U069	INSULATED COPPER CABLE 50mm ² - 500m drum	50 (19x1.80)	1.40	0.387	11.8	479	1
U070	INSULATED COPPER CABLE 70mm ² - 500m drum	70 (19x2.12)	1.40	0.268	13.4	669	1
U071	INSULATED COPPER CABLE 95mm ² - 500m drum	95 (19x2.49)	1.60	0.193	15.65	920	1
U072	INSULATED COPPER CABLE 120mm ² - 500m drum	120 (37x2.00)	1.60	0.153	17.2	1130	1
U073	INSULATED COPPER CABLE 150mm ² - 500m drum	150 (37x2.21)	1.80	0.124	19.07	1395	1
U074	INSULATED COPPER CABLE 185mm ² - 500m drum	185 (37x2.46)	2.00	0.0991	21.22	1712	1
U075	INSULATED COPPER CABLE 240mm ² - 500m drum	240 (37x2.82)	2.20	0.0754	24.14	2260	1
U076	INSULATED COPPER CABLE 300mm ² - 500m drum	300 (37x3.20)	2.40	0.0601	27.2	2872	1

Tape

Copper



The copper gives an important electrical conductivity.

MIRELEC

Application

This tape is designed to conduct the electricity into the earth system and to guarantee the default current runoff.

Code	Designation	Section (mm ²)	Width (mm)	Thickness (mm)
U077	COPPER TAPE 20x3 L=100m	60	20	3
U078	COPPER TAPE 25x3 *	75	25	3

*Tape delivered in roll or drum. Consult us.

Copper bonded steel

The copper bonded steel offers a good economical alternative to copper.

Code	Designation	Section (mm ²)	Width (mm)	Thickness (mm)	Length (m)
U080	COPPER BONDED STEEL TAPE 20x3 L=60m	60	20	3	60
U081	COPPER BONDED STEEL TAPE 25x3 L=40m	75	25	3	40
U082	COPPER BONDED STEEL TAPE 25x4 L=30m	100	25	4	30
U083	COPPER BONDED STEEL TAPE 30x3 L=40m	90	30	3	40
U084	COPPER BONDED STEEL TAPE 30x4 L=30m	120	30	4	30
U085	COPPER BONDED STEEL TAPE 40x4 L=20m	160	40	4	20

Tinned copper bonded steel

The tinned coating protects from theft thanks to the non visible copper coating.

Code	Designation	Section (mm ²)	Width (mm)	Thickness (mm)	Length (m)
U086	TINNED COPPER BONDED STEEL TAPE 20x3 L=60m	60	20	3	60
U087	TINNED COPPER BONDED STEEL TAPE 25x3 L=40m	75	25	3	40
U088	TINNED COPPER BONDED STEEL TAPE 25x4 L=30m	100	25	4	30
U089	TINNED COPPER BONDED STEEL TAPE 30x3 L=40m	90	30	3	40
U090	TINNED COPPER BONDED STEEL TAPE 30x4 L=30m	120	30	4	30
U091	TINNED COPPER BONDED STEEL TAPE 40x4 L=30m	160	40	4	30

Galvanized steel

Galvanized steel is an economical solution to coppered tinned steel and protect from the theft too. It has a good conductivity.

Code	Désignation	Section (mm ²)	Largeur (mm)	Épaisseur (mm)	Longueur (m)
U100-4	GALVANIZED STEEL TAPE 30x4 L=50m	120	30	4	50
U101-4	GALVANIZED STEEL TAPE 40x4 L=38m	160	40	4	38

Stainless steel cruciform clamp



U092

Application

This cruciform clamp is designed to perform a connection between the earth rod and the conductor or between two conductors.

Code	Designation	Nominal rod diameter (mm)	Tape length (mm)	Cable section (mm ²)	Screw	Weight (kg)	Sales unit
U092	STAINLESS STEEL CRUCIFORM CLAMP ROD DIAM 12.7 AND 14	14-16	≤ 40	28-78	M10	0.315	2
U093	STAINLESS STEEL CRUCIFORM CLAMP ROD DIAM 17.2	19	≤ 40	28-78	M10	0.400	2

Aluminium earth cable and accessory

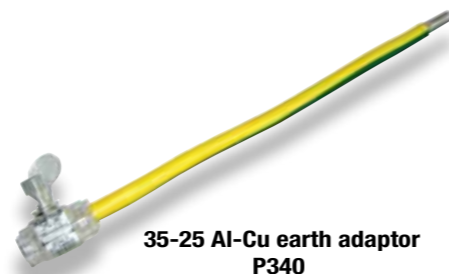
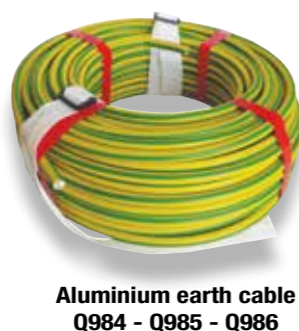

MICHAUD

Application

The earth distributor is used to connect floor earths between themselves. It is installed in a building pillar according to applicable specifications. The ground cutting blade is installed at the bottom of the earth pillar. It enables the earth system opening during an earth resistance measurement.

Benefits:

- + Aluminum terminals admitting copper or aluminium cable
- + Reversible box cover protecting the ground cutting blade
- + Earth distributor designed for an esthetic installation in 60x60mm conduit in case of renovation

Description

- The earth distributor can receive:
 - 1 cable **50mm²** maximum without cutting (main line)
 - 6 possible taps 35mm² maximum
- It comprises an aluminium profile with shear head screws and insulation piercing and a box in synthetic materials giving it a protection degree type IPXXB.
- It is equipped with a handle offering a possible sealing.
- The ground cutting blade with box is equipped with:
 - An insulation piercing superior terminal block in tinned aluminium with shear head screws (no need of stripping)
 - A copper blade
 - An inferior terminal block in brass
 - A synthetic materials box with reversible opening and closing way, giving it a protection degree type IP44D
- It can receive **aluminium cable section from 25 up to 50mm²** and **copper cable section from 16 up to 35mm²**.
- The distribution board adaptor Al/Cu comprises:
 - A flexible tail 25mm², length 230mm
 - A shear head screw
- It can receive cable sections from 25 up to 35mm²
- Its use is requested for the connection of the individual protection connector and the earth terminal block of the distribution board, when this one cannot receive aluminium.
- The earth cable FR-N-07V-AR is made of aluminium. It is delivered in ring with 2 straps making transportation easier and a box of 25 identification labels marked "Alu".
- It is available in 3 sections: 25, 35, 50mm².
- It meets the requirements of **NF C32-208**.

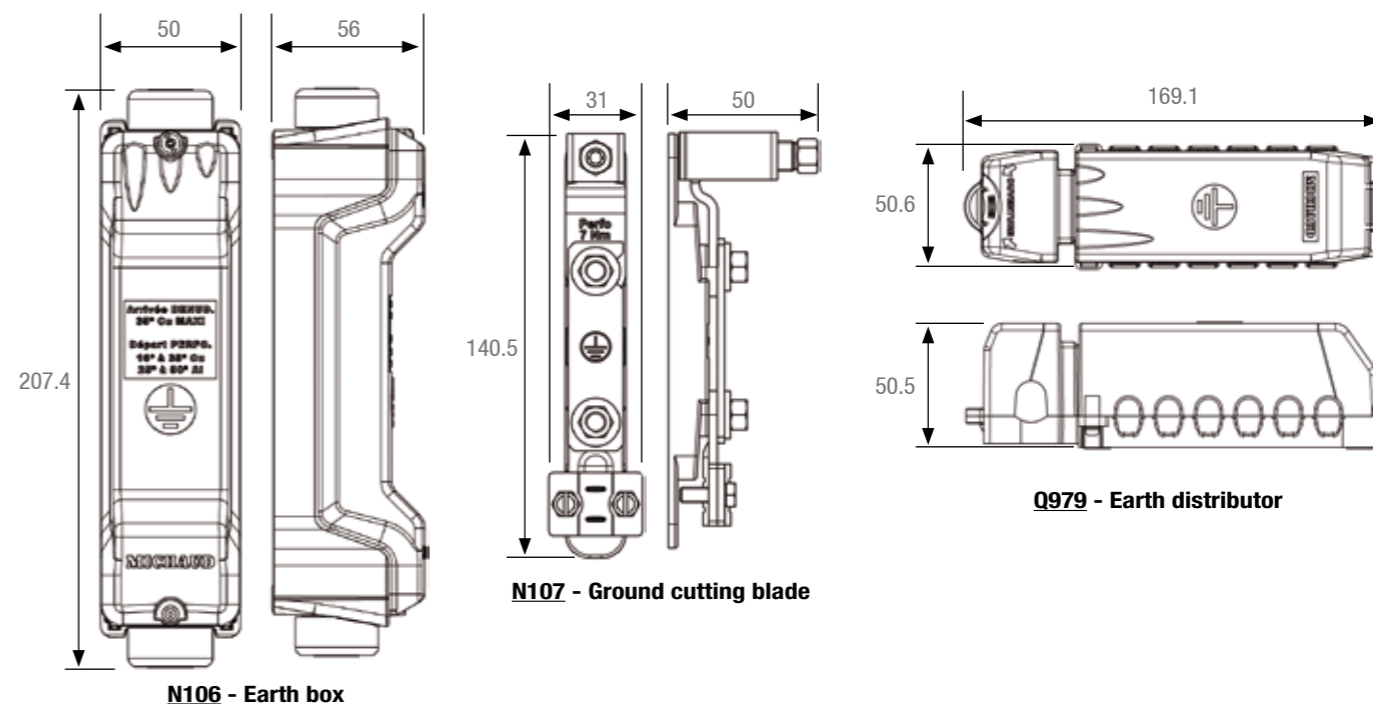

Code	Designation	Sales unit
N106	GROUND CUTTING BLADE ALUMINIUM WITH BOX	1
N107	GROUND CUTTING BLADE BARE AL	1
Q979	EARTH DISTRIBUTOR AL 6 TAPS	1
Q984	ALUMINIUM EARTH CABLE 25 ² 100M	1
Q985	ALUMINIUM EARTH CABLE 35 ² 100M	1
Q986	ALUMINIUM EARTH CABLE 50 ² 50M	1
P340	AL/CU EARTH ADAPTOR 35-25	10

Variants: Stripping technology

These products using the stripping technology require a brushing with neutral grease during installation.



Code	Designation	Sales unit
ED001	EARTH DISTRIBUTOR STRIP AL 5 TAPS	1
ED002	EARTH DISTRIBUTOR STRIP AL 8 TAPS	1
ED003	GROUND CUTTING BLADE AL STRIP	1

Accessories

Code	Designation	Sales unit
BOX FOR CUTTING BLADE ALONE The box can be sold alone to receive for example a ground cutting blade for copper, Ref U036		
N108	BOX FOR GROUND CUTTING BLADE	1
LABELS AL CABLE These labels enable to identify aluminium cable		
N109	BOX OF 25 LABELS AL CABLE	1

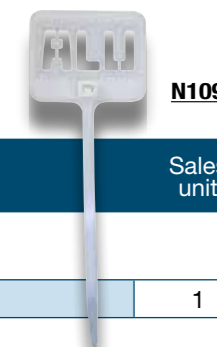

Underground



Underground

Underground service

Multipole ring connector 150mm ²	p.154
Multipole ring connector 240mm ²	p.156
Multipole ring connector 300mm ²	p.158
Single pole service connector.....	p.160
Tap and junction gel box.....	p.162
Service repairing function kit - JRB.....	p.164

Underground network

Single pole network connector.....	p.166
Mechanical tightening underground junction 1kV - Heat-shrinkable.....	p.168
Short-circuiting lost end - BPMCC.....	p.170
Aerial sub-surface connections for LV network (EJAS).....	p.172

Emerging connection

REMIC set of bars.....	p.174
REMIC service module.....	p.176
REMIC network module.....	p.178
REMIC disconnection and protection module.....	p.180

Accessories

Protection and warning.....	p.182
Cold shrinkable seal.....	p.184



With a solid experience acquired in insulated cables connections, MICHAUD expanded its skills to **the underground field.**

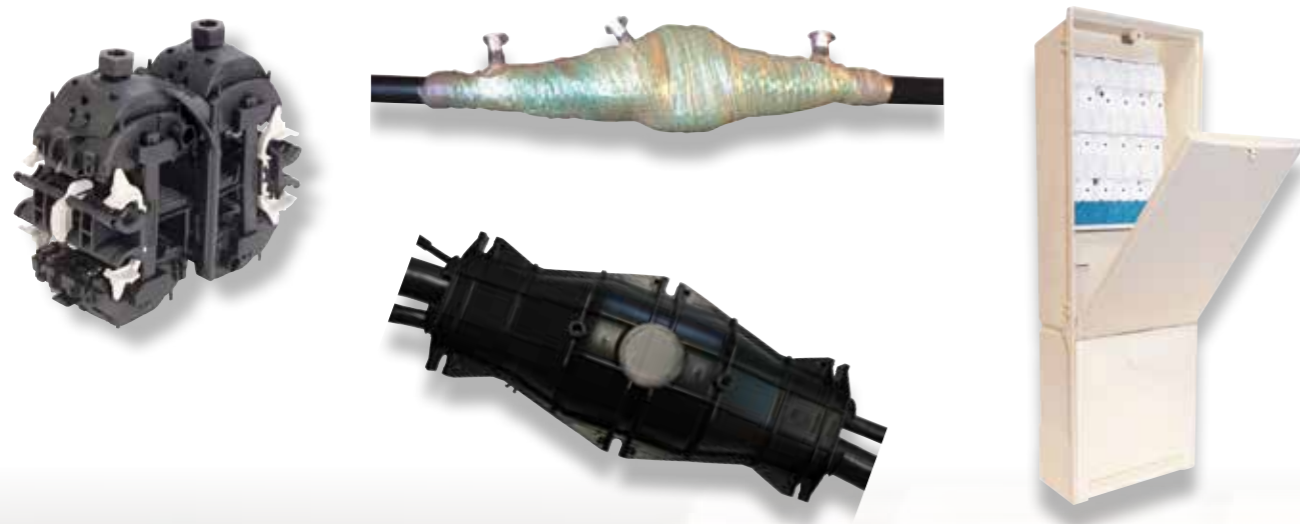

Underground networks

Many assets

The use of underground technology is growing. Buried networks offer many benefits compared to overhead ones.

- Safety**
 - + To reduce incidents risk
 - + To reduce electrical contacts risk
- Quality**
 - + To increase lines durability
 - + To guarantee a service without disruptions in case of violent winds, storms...
- Optimization**
 - + Preservation of ground for building
 - + Limit fraudulent manipulation
- Aestheticism**
 - + No pollution landscape

Underground

Underground

A recognized experience in the sector



The company developed the underground field, based on its **skills acquired** in insulation piercing technology demonstrating **high innovation ability**.



The underground field requires a high level of reliability. Mistakes during installation can be expensive and MICHAUD reduces risks with **high technical equipment** and establishes itself as a leader of buried connections.



This field matches with **new applications** such as the three-phase supply, electrical cars load, air conditioners designing solutions suitable for higher power conductors.

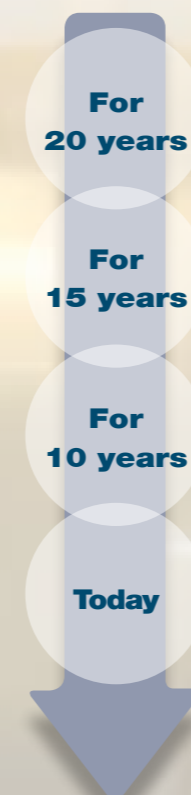

Development of single phase connectors

Co-operation with cable manufacturers

Establishment of new generation of RING connectors

Distribution of solutions around the world

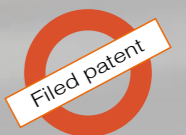



Three levels of installations

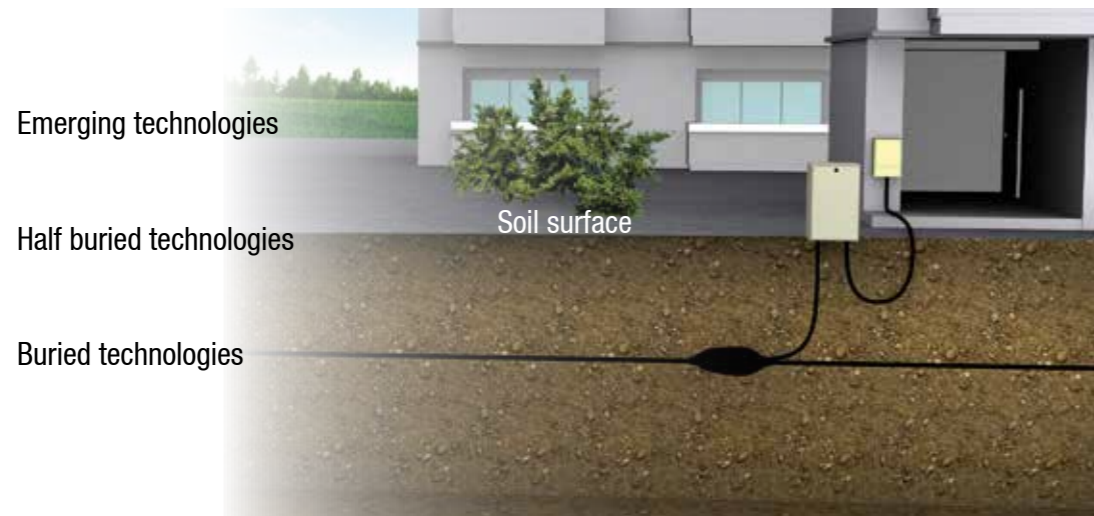

1 - Buried solutions

To enable the achievement of connections and tap-connections in underground environment, MICHAUD designed watertight systems avoiding water penetration being able to run over 30 years without maintenance.



Zoom on RING connector and the underground service box

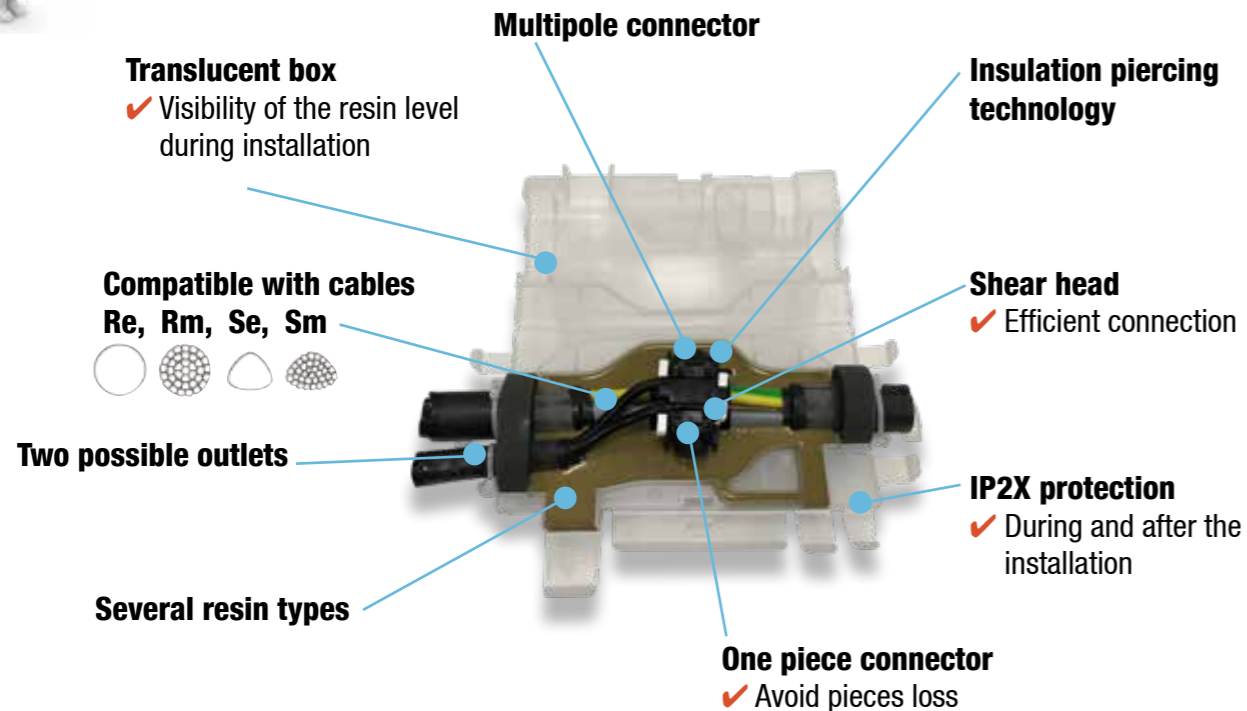

2 - Half-buried solutions

These solutions give the advantage to follow the requirements due to an operation in underground environment while being accessible from the soil surface.



Zoom on the pit cutout sleeve

This sleeve enables the protection of the underground network connection.

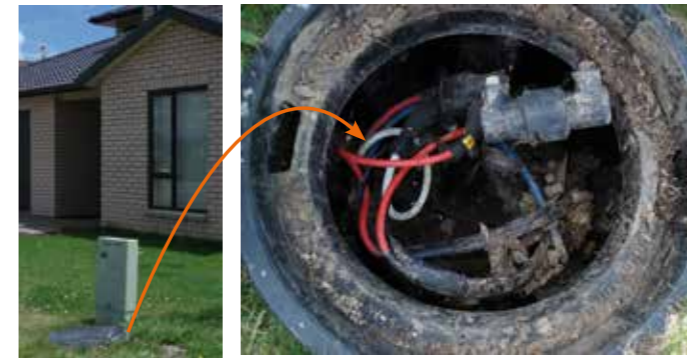

- ✓ Installation in a pit
- ✓ Full waterproof connection
- ✓ Temporary working into water



3 - Emerging connection solutions

The modular range of emerging cabinets makes possible an adaptation to different searched configurations.

1 - Cabinet

2 - Set of bars

3 - Modules

- ✓ Service / Network
- ✓ Single phase / Three phases
- ✓ One outlet / Several outlets
- ✓ Fuse protection

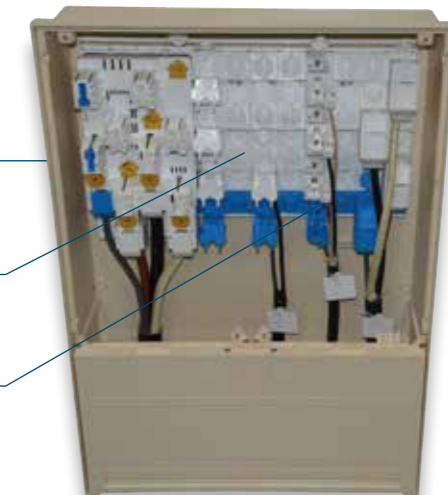

Set of bars and modules are suitable to every type of cabinets in order to insert inside the environment, keeping the existing.



In order to better suit the market expectations, **Michaud Export** encourages co-development.



Many solutions adapted to conductors

Michaud guides you in your installations



- + Showroom
- + Video to explain the installation
- + Training by our team

Application field

Service



	150mm ²	240mm ²	300mm ²
Main section	95-150mm ²	50-240mm ²	150-300mm ²
Tap section	1x10-35mm ²	2x10-35mm ²	2x10-35mm ²
Volume	2.1 liters	6 liters	6 liters
Work space	170 max	330 max	
Connector diameter	119mm	140mm	150mm

Network

Realization of connection or tap-connection

Conductors capacity
✓ Up to 240mm²

Unipolar technology

- ✓ Three phases
- ✓ One neutral

Round or sectoral conductor

Technology

- ✓ Cast
- ✓ Injected

Underground

Underground

Two technologies

Cast technology

The +
Easy installation

The -
No possible flexibility in the installation configuration

Injected technology

The +
Easy adaptation to specific environments

The -
Installation requiring fitters training



The polyurethane resin

- ✓ Used injected or cast
- ✓ Polymerized at ambient temperature
- ✓ Perfectly suitable to MICHAUD underground boxes
- ✓ High mechanical strength
- ✓ Perfect adhesion on synthetic material as well as on modern accessories

+ Soft dismantable non hazardous resin is also available



Multipole ring connector 150mm²

Exclusivity
PATENTED SYSTEM
Michaud Export



K449

MICHAUD

Application

This RING connector is designed to establish a tap connection on low voltage underground networks. It is installed inside an underground box. It is used on a main cable with the following type of synthetic insulation:

- Circular or sectoral,
- Copper or aluminium,
- Solid or stranded core.

Description

- Connection is ensured through insulation piercing technology, simultaneously on main and tap lines.
- Connector capacities are 95 to 150mm² main and 1x10 to 35mm² tap.
- The connector accepts a reduced neutral.
- Adjustable clips are used to guide the cable and act as stops. The tap can be established on the right or left.
- The connector comprises:
 - 2 identical IP2X tightening modules enabling non-oriented mounting and simultaneous tightening from the top.
 - 1 cleat for locking the modules and for permanently securing the connector on the cable.
- The body is made of synthetic materials to make live-line work safe.
- The ergonomics has been designed to meet the specific constraints of underground work.
- Tightening efficiency is ensured by 2 shear heads, thereby reducing the assembly time.
- All connector components are captive to make the installation easier.
- The connector dimensions once implemented: $\varnothing \leq 119\text{mm}$.
- IP2X connector once implemented.

This connector is tested according to the **DIN VDE 0220** and **DIN EN 50393** standards.

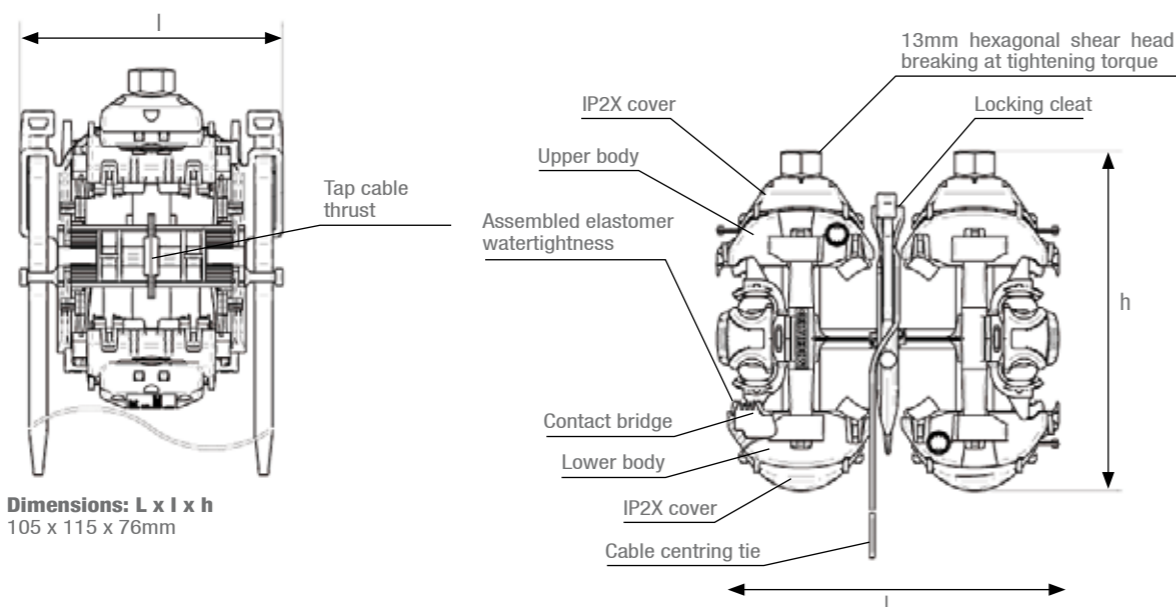

Code	Designation	Main Capacities (mm ²)	Tap Capacities (mm ²)	Weight (kg)	Sales unit
K449	4 POLES SERVICE CONNECTOR 150 / 1x35	95-150	1 x 10-35	0.450	10

For compatibility with your conductors, please contact us (cable compatibility shall be tested before use).

Accessory



The insulated wedge separator is used for installing the multitap connector. It is used to separate the conductors.

Code	Designation	Weight (kg)	Sales unit
K007	WEDGE SEPARATOR 200x15x9mm	0.050	100

Underground box

MICHAUD

Utilisation

This underground box enables the tap connection from an underground network. It makes possible the tap connection of every conductors type (stranded, solid, multi-stranded, round or sectoral). It comprises the connector, the resin, the box and accessories according to the local standard.



K450

Description

- The box comprises a translucent shell made of thermoplastic material (PP).
- Box accessories required for the assembly are supplied: section reducer, strips of adhesive foam, foams, links, gloves, etc.
- The polyurethane resin, delivered in a dual-bag, is qualified according to the **NF C33-010** (MPF01/DC and MPF PM) and **HD631.1** (LMPW, LIN, MMPW, NIW) standards.
- Once implemented, the dimensions of the box are 380x180x150mm.
- The connector shapes are studied to perform a good display of the resin.

The underground box is tested according to the **DIN EN 50393** standard.

Code	Designation	Capacities (mm ²)	Weight (kg)	Sales unit
K450	MULTIPOLE CONNECTOR 150 + UNDERGROUND BOX	95-150 / 1x10-35	4.300	1

For compatibility with your conductors, please contact us (cable compatibility shall be tested before use).

Multipole ring connector 240mm²

Exclusivity
PATENTED SYSTEM
Michaud Export



K459

MICHAUD

Application

This RING connector is designed to establish a tap connection on low voltage underground networks. It is installed inside an underground box. It is used on a main cable with the following type of synthetic insulation:

- Circular or sectoral,
- Copper or aluminium,
- Solid or stranded core.

Description

- Connection is ensured through insulation piercing technology, simultaneously on main and tap lines.
- Connector capacities are: 50 to 240mm² main and 1 up to 2x10 to 35mm² tap.
- The connector accepts a reduced neutral.
- Adjustable clips are used to guide the cable and act as stops. The tap can be established on the right or left.
- The connector comprises:
 - 2 identical IP2X tightening modules enabling non-oriented mounting and simultaneous tightening from the top.
 - 1 cleat for locking the modules and for permanently securing the connector on the cable.
- The body is made of synthetic materials to make live-line work safe.
- The ergonomics has been designed to meet the specific constraints of underground work.
- Tightening efficiency is ensured by 2 shear heads, thereby reducing the assembly time.
- All connector components are captive to make the installation easier.
- IP2X connector once implemented.

This connector is tested according to 1 000 cycles electrical ageing according to the **EN 61 238-1** standard.

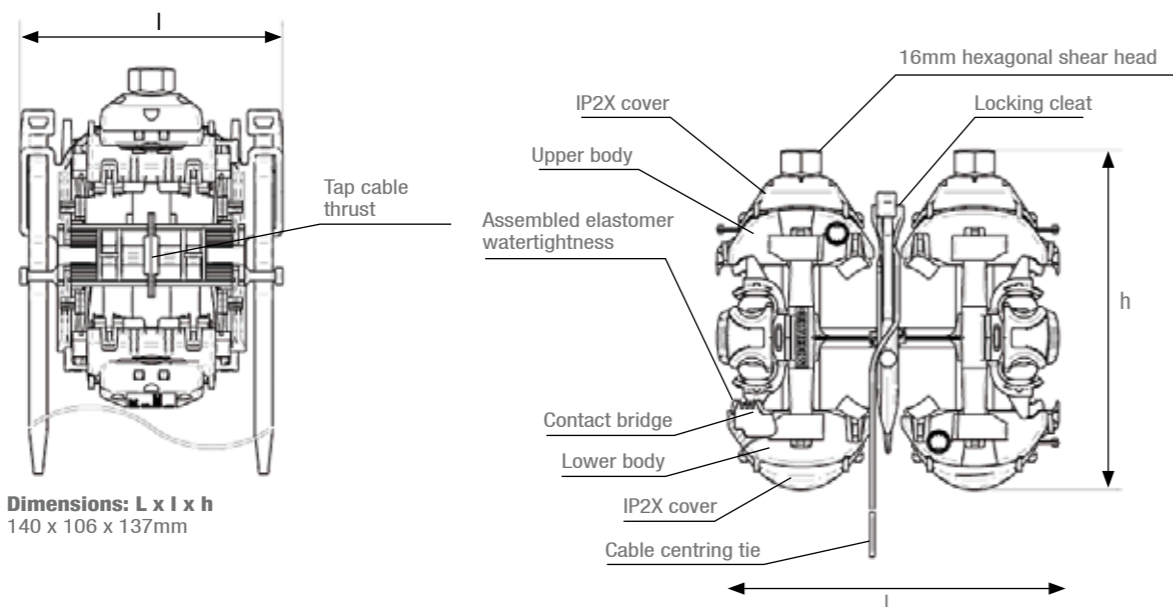

Code	Designation	Main Capacities (mm ²)	Tap Capacities (mm ²)	Weight (kg)	Sales unit
K459	4 POLES SERVICE CONNECTOR 240 / 2x35	50-240	2 x 10-35	0.820	8

For compatibility with your conductors, please contact us (cable compatibility shall be tested before use).

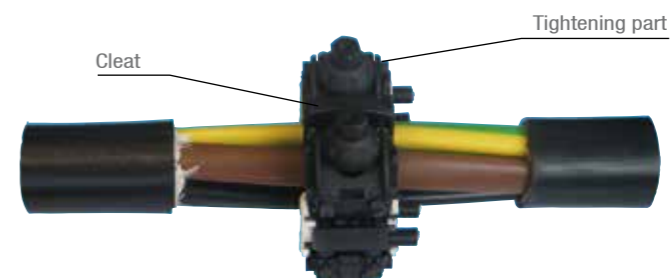

Accessory



This kit comprising a cable and a blue synthetic sheath is used as a complement to the K459 to ensure earth system of the multitap connector.

The insulated wedge separator is used for installing the multitap connector. It is used to separate the conductors.

Code	Designation	Weight (kg)	Sales unit
K007	WEDGE SEPARATOR 200x15x9mm	0.050	100

Underground box



K645

MICHAUD

Application

This underground box enables the tap connection from an underground network. It makes possible the tap connection of every conductors type (stranded, solid, multi-stranded, round or sectoral). It comprises the connector, the resin, the box and accessories according to the local standard.

Description

- The box comprises a translucent shell made of thermoplastic material (PP).
- The box is available in 2 versions: injected box or cast box.
- Box accessories required for the assembly are supplied: section reducer, strips of adhesive foam, foams, links, gloves, etc.
- The polyurethane resin, delivered in a dual-bag, is qualified according to the **NF C33-010** (MPF01/DC and MPF PM) and **HD631.1** (LMPW, LIN, MMPW, NIW) standards.
- Once implemented, the dimensions of the box are 540x240x190mm.
- The connector shapes are studied to perform a good display of the resin.

Code	Designation	Main Capacities (mm ²)	Tap Capacities (mm ²)	Weight (kg)	Sales unit
K640	SERVICE BOX MULTI-CONNECTION INJECTED 240-35	50-240	2x10-35	15	10
K645	SERVICE BOX MULTI-CONNECTION CAST 240-35	50-240	2x10-35	15	10

For compatibility with your conductors, please contact us (cable compatibility shall be tested before use).

Multipole ring connector 300mm²

Exclusivity
PATENTED SYSTEM
Michaud Export



K642

MICHAUD

Application

This RING connector is designed to establish a tap connection on low voltage underground networks. It is installed inside an underground box. It is used on a main cable with the following type of synthetic insulation:

- Circular or sectoral,
- Copper or aluminium,
- Solid or stranded core.

Description

- Connection is ensured through insulation piercing technology, simultaneously on main and tap lines.
- Connector capacities are 240 to 300mm² main and 1 up to 2x10 to 35mm² tap.
- The connector accepts a reduced neutral.
- Adjustable clips are used to guide the cable and act as stops. The tap can be established on the right or left.
- The connector comprises:
 - 2 identical IP2X tightening modules enabling non-oriented mounting and simultaneous tightening from the top.
 - 1 cleat for locking the modules and for permanently securing the connector on the cable.
- The body is made of synthetic materials to make live-line work safe.
- The ergonomics has been designed to meet the specific constraints of underground work.
- Tightening efficiency is ensured by 2 shear heads, thereby reducing the assembly time.
- All connector components are captive to make the installation easier.
- IP2X connector once implemented.

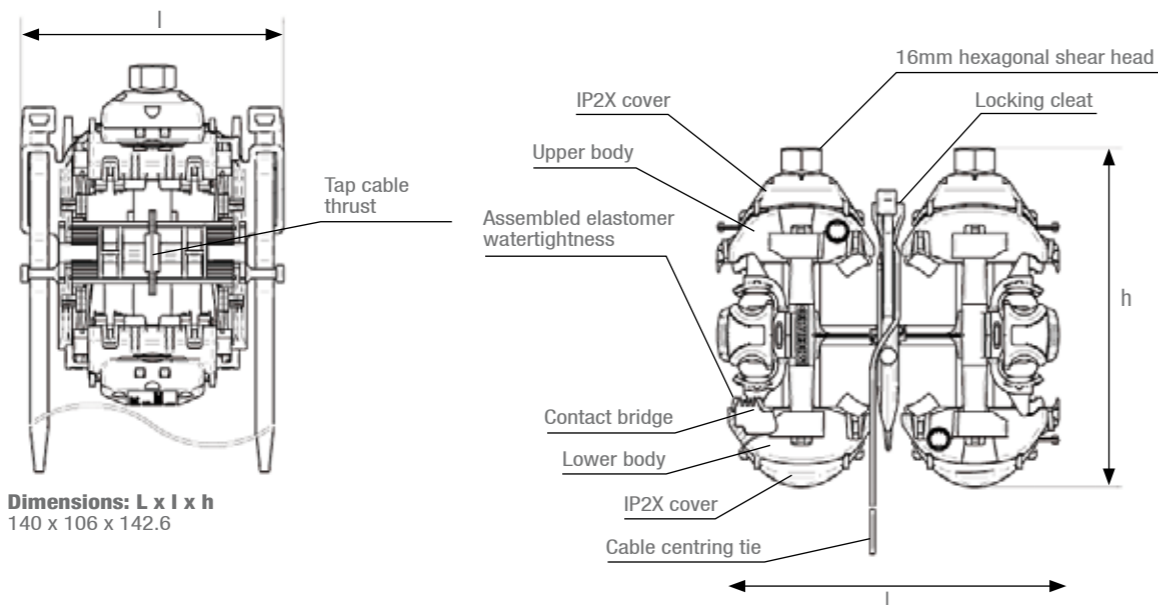

Code	Designation	Capacities Main (mm ²)	Capacities Tap (mm ²)	Weight (kg)	Sales unit
K642	4 POLES SERVICE CONNECTOR 300 / 2x35	240-300	2x10 - 35	0.850	10

For compatibility with your conductors, please contact us (cable compatibility shall be tested before use).

Accessory



The insulated wedge separator is used for installing the multitap connector. It is used to separate the conductors.

Code	Designation	Weight (kg)	Sales unit
K007	WEDGE SEPARATOR 200x15x9mm	0.050	100

Underground box



K646

MICHAUD

Application

This underground box enables the tap connection from an underground network. It makes possible the tap connection of every conductors type (stranded, solid, multi-stranded, round or sectoral). It comprises the connector, the resin, the box and accessories according to the local standard.

Description

- The box comprises a translucent shell made of thermoplastic material (PP).
- The box is available in 2 versions: injected box or cast box.
- Box accessories required for the assembly are supplied: section reducer, strips of adhesive foam, foams, links, gloves, etc.
- The polyurethane resin, delivered in a dual-bag, is qualified according to the **NF C33-010** (MPF01/DC and MPF PM) and **HD631.1** (LMPW, LIN, MMPW, NIW) standards.
- Once implemented, the dimensions of the box are 540x240x190mm.
- The connector shapes are studied to perform a good display of the resin.

Code	Designation	Capacities Main (mm ²)	Capacities Tap (mm ²)	Weight (kg)	Sales unit
K646	SERVICE BOX MULTI-CONNECTIONS CAST + CONNECTOR 300 ²	240-300	2x10-35	15.050	10

For compatibility with your conductors, please contact us (cable compatibility shall be tested before use).

Single pole service connector

1 tap



Phase - **K317**



Neutral - **K318**

2 taps



Phase - **K419**



Neutral - **K420**

MICHAUD

Application

This connector is designed to establish a tap connection on low voltage underground networks. It is located in underground cast or injected boxes. It can be used on a main cable with paper or synthetic insulation of type:

- circular or sectoral,
- aluminium,
- stranded or solid core.

Description

- Connection is ensured through insulation piercing technology simultaneously on main and tap lines.
- The K419 and K420 models can be used for connecting 2 taps with identical or different sections.
- The K420 model integrates an earth system conductor.
- Connectors are fully insulated (IP2X protection degree). Bodies are made of synthetic materials to make live-line work safe.
- The ergonomics has been designed to meet the specific constraints of underground work.
- Tightening efficiency is ensured by a shear head screw.

The components are tested for 200 cycles according to the **NF C 63-061** and 1 000 cycles electrical ageing according to the **NF EN 61238-1** standards.

Code	Designation	Main Capacities (mm ²)	Tap Capacities (mm ²)	Weight (kg)	Sales unit
K317	CONNECTOR CBS/CS 240	50-240	10-35	0.230	3
K318	CONNECTOR CBS NEUTRAL/CS	50-95	10-35	0.135	1
K419	CONNECTOR CB2p/CS 240	50-240	2x10-35	0.200	3
K420	CONNECTOR CB2p NEUTRAL/CS	50-95	2x10-35	0.310	1

Accessory



K001

End cap is used in addition to the K317 and K318 connector in order to insulate the end of the tap cable.

Code	Designation	Weight (kg)	Sales unit
K001	BLACK FLEXIBLE END CAP 10-50M	0.003	20

Underground box



MICHAUD

Application

This underground service box is designed to establish a single or double tap from one or 2 line connections from an underground network made up of round or sectoral conductors (as defined in **NF C 33-210**).

Description

- The box is available in injected or cast version:
- SDI or SDC: injected or cast single tap service box.
 - DDI or DDC: injected or cast double tap service box.
- Small models have been developed for single phase applications (single phase SDI-R).
 - Each kit comprises all of the equipment needed for the installation:
 - Insulation piercing connectors,
 - Adhesive tape and resin for the injected boxes,
 - 2 semi-housings and resin for the cast boxes.
 - Injected box models for earlier generation cables (impregnated paper cables) can be supplied upon request.

Code	Designation	Main Capacities (mm ²)	Tap Capacities (mm ²)	Weight (kg)	Sales unit
K630	SINGLE-OUTLET CAST BOX (SDC) *	50-240	1x10-35	ND	1
K631	DOUBLE-OUTLET CAST BOX (DDC) *	50-240	2x10-35	ND	1

* Products manufactured upon request.

Tap and junction gel box

MICHAUD

Application

These gel boxes are designed to establish low voltage conductor junction or tapping. They protect, insulate and make the connection waterproof in a single work operation. They comprise a connector trapped in gel once the product has been implemented. This connector can be dismantled. The box can be implemented in soil or water. It can be reused several times. It is not resistant to UV.



Description

- The box has an integrated gel enabling the product to be assembled and dismantled.
- The gel ensures the waterproofing and insulation functions whereas the box ensures the mechanical functions (shock-absorbing). The gel is stable at temperature between -60 and +200°C.
- The product is watertight under water up to 1m.
- Installation is carried out with neither any special tool, nor flame.
- The connector is dimensioned for 3 up to 5 conductors. It is delivered with an hexagonal spanner with 6 faces spanner for its installation.
- The box is made of shock-resistant, halogen-free PP synthetic materials.

The product meets the criteria of the **DIN EN 50393** standard.

Junction application

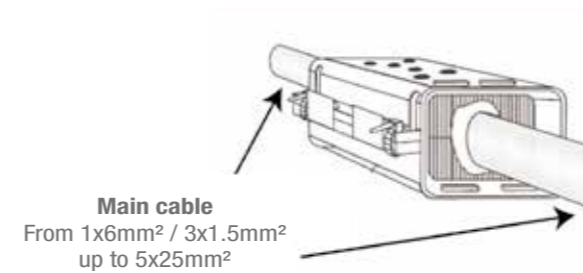

Tap application

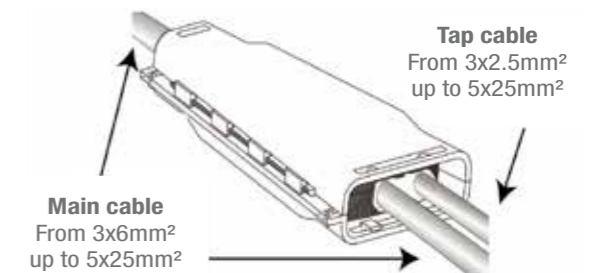

Code	Designation	Number of conductors	Main capacity mini / maxi (mm²)	Tap capacity mini / maxi (mm²)	Dimensions L x l x D (mm)	Weight (kg)	Sales unit
GEL CONNECTION BOXES - JUNCTION WITH CONNECTOR							
N708	QUICKGEL 125C	1	6-25	-	86 x 47 x 27	0.125	1
N709	QUICKGEL 32.5C	3	1.5-2.5	-	86 x 47 x 27	0.085	1
N710	QUICKGEL 506C	3 up to 5	1.5-6	-	146 x 55 x 35	0.275	1
N711	QUICKGEL 516C	3 up to 5	6-16	-	180 x 69 x 40	0.470	1
N712	QUICKGEL 425P	4 (piercing)	6-25	-	240 x 75 x 43	0.785	1
N713	QUICKGEL 525P	4 (piercing) + 1 (stripping/earth system)	6-25	-	240 x 75 x 43	0.855	1
GEL CONNECTION BOXES - JUNCTION / TAPPING WITH CONNECTOR							
N714	QUICKGEL 516YC	3 up to 5	6-16	2.5-6	220 x 110 x 53	0.780	1
N715	QUICKGEL 525YC	3 up to 5	16-25	2.5-25	260 x 130 x 65	1.290	1
GEL CONNECTION BOXES WITHOUT CONNECTOR							
N716	QUICKGEL 100				86 x 47 x 27	0.070	1
N717	QUICKGEL 500				146 x 55 x 35	0.185	1
N718	QUICKGEL 510				180 x 69 x 40	0.330	1
N719	QUICKGEL 520				240 x 75 x 43	0.610	1

Service repairing junction kit - JRB

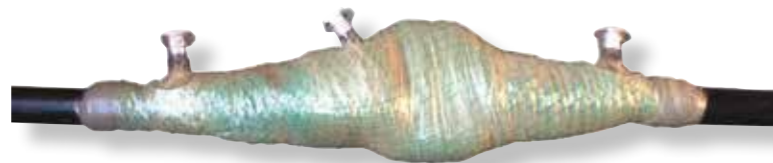

BE004

MICHAUD

Application

This accessory is designed to repair connection of service underground damaged cables.

Description

- This kit comprises the following accessories:
 - 4 pre-insulated junction sleeves using insulation piercing technology,
 - 1 device enabling the reconstitution of the cable screen,
 - 1 hardening resin.
- The installation is of ribboning / injection type.

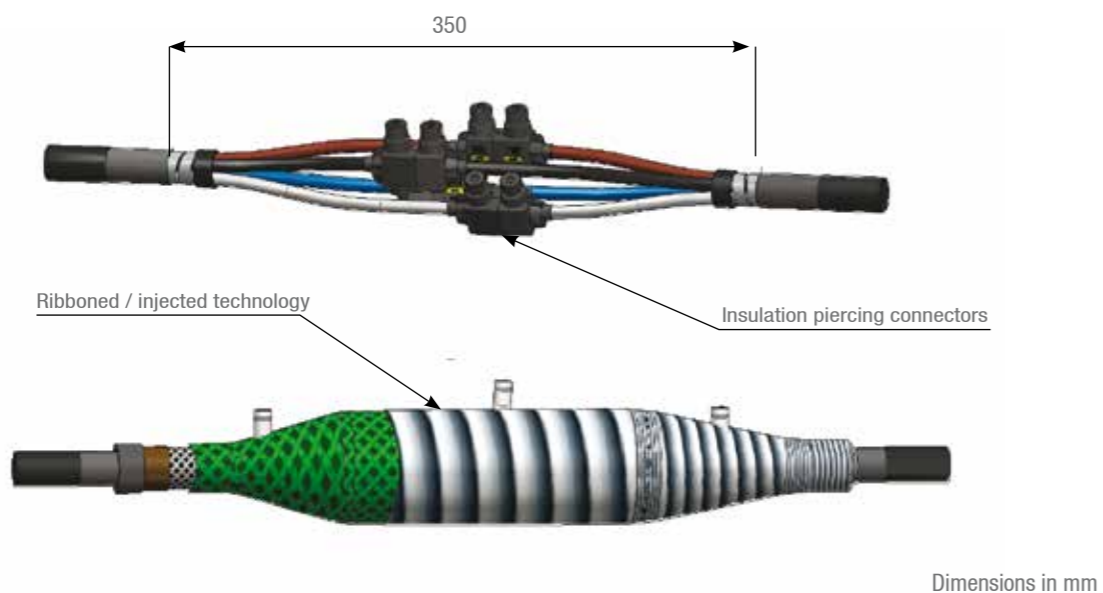

Installation

- Cables preparation



- Cables connection

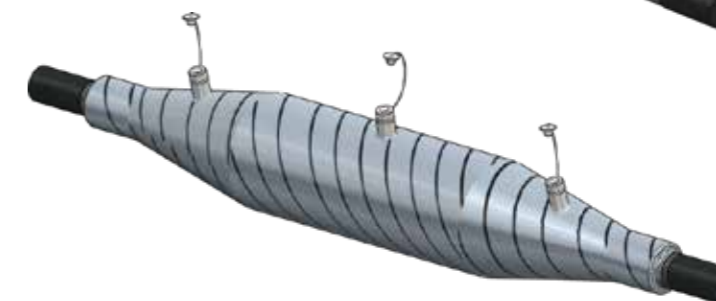

- Ribboning

- Resin injection

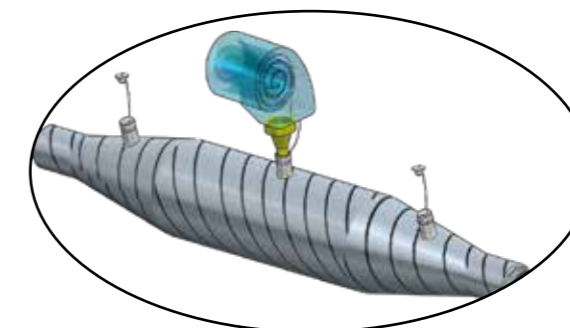

Code	Designation	Cable section (mm ²)		Weight (kg)	Sales unit
		Mini	Maxi		
BE004	SERVICE REPAIRING JUNCTION KIT JRB 10-50	4x10	4x35	2.97	1

Single pole network connector

MICHAUD

Application

This connector is designed to be used with underground low voltage network for tapping or junction applications. It is implemented in underground cast or injected boxes. It can be used on aluminium, circular or sectoral type cables with paper or synthetic insulation.



Phase 50-240 / 50-240
K383



Phase 50-240 / 50-150
K384



Phase 50-95 / 50-95
K313



Neutral 50-150 / 50-95
K360

Description

- Connection is established simultaneously using insulation piercing technology on the main and tap lines.
- The connectors are fully insulated (IP2X degree of protection). Their bodies are made of synthetic materials to make live-line work safe.
- They are tested for 1 000 cycles electrical ageing according to the **NF EN 61238-1** standard.
- The dielectric strength in air is greater than 4kV.
- The ergonomics has been designed to meet the specific constraints of underground work.
- Tightening efficiency is ensured by shear head screws.

These connectors meet the criteria of the technical specification **HN 68 S-12**.

Code	Designation	Main Capacities (mm ²)	Tap Capacities (mm ²)	Weight (kg)	Sales unit
K383	CONNECTOR CDR/CS 50-240	50-240	50-240	0.700	1
K384	CONNECTOR CDR/CS 50-240/50-150	50-240	50-150	0.400	1
K313	CONNECTOR CDR/CS 50-95	50-95	50-95	0.210	3
K360	CONNECTOR CDR NEUTRAL/CS 50-95	50-150	50-95	0.210	1

Accessories



K247



K002

The end cap K247 and K002 are used in addition to K383 + K384 and K313 + K360 respectively for the insulation of the tap cable end.

SEE SHEET
OVERHEAD / LV Ending fitting / Seal and cap



K314

This connector is designed for earthing the neutral. For the supply of the earth system cable, please contact us.

Code	Designation	Weight (kg)	Sales unit
K314	EARTH SYSTEM CONNECTOR 50-95 / 25	0.140	1

Underground network box



MICHAUD

Application

This underground network box is designed to establish the junction or tap from a round or sectoral underground network (as defined in the **NF C 33-210** standard).

Description

- The box is available in cast version (JNC: tap or junction cast box).
- Each kit comprises all the equipment required for the installation:
 - Insulation piercing connectors (see details on the underground network connectors page),
 - Adhesive tape and resin for the injected box,
 - 2 semi-housings and resin for the cast box.
- An injected box is available for earlier generation cables upon request.

Code	Designation	Main Capacities (mm ²)	Tap Capacities (mm ²)	Weight (kg)	Sales unit
K610	CAST JUNCTION BOX 95-95 (JNC) *	50-95	50-95	4.520	1
K612	CAST JUNCTION BOX 240-240 (JNC) *	95-240	95-240	5.430	1

* Products manufactured on request. Please contact us.

Mechanical tightening underground junction 1kV - Heat-shrinkable



Sleeves

MICHAUD

Application

This set is designed to perform low voltage underground cables junctions. The system can be buried once implemented.

It comprises junction sleeves, heat-shrinkable sheaths and an abrasive strip. Junction sleeves use mechanical tightening enabling to cover a wide sections range and an easier installation. The delivered heat-shrinkable sheaths make possible the insulation reconstitution of the conductor and the outside sheath.



Sheaths

Abrasive strip

Description

Junction sleeves:

- Junction sleeves are made of tinned aluminium enabling the compatibility with aluminium and copper cables.
- The shear head tightening ensures an optimized electrical contact and a sleeve shape suitable to the heat-shrinkable sheath covering.
- Sleeves offer a central stop and ensure a water barrier because of non-through piercing.
- The cable range sections are from 16 up to 300mm².
- Sectoral cores shall be rounded before connection.
- Sleeves meet the criteria of the **EN 61 281-1** class A standard.

Heat-shrinkable sheaths:

- Internal sheaths ensure the insulation of every conductor. External sheaths rebuild the mechanical protection.
- They can be used from -40°C up to +90°C.
- Sheaths are without halogen and are resistant to UV, mould and chemical substances.
- They are qualified according to the criteria of the **IEC 60 684** standard.
- The sheaths internal surface is covered with glue ensuring a good watertightness once heated and implemented.
- A strip is supplied in order to abrade the cable insulation and to ensure a good adhesion with the heat-shrinkable sheath.
- Other kits are available according to conductors nature and shape : contact us.

The whole set meets the criteria of the **EN 50 393-3** standard.

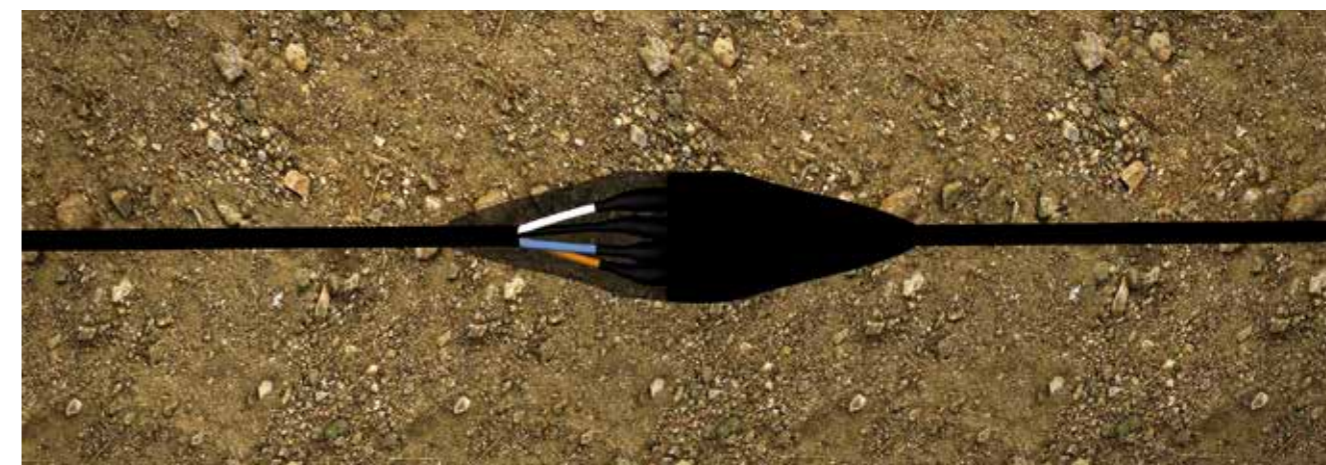

Code	Designation	Weight (kg)	Sales unit
U560-25	JUNCTION 1KV HEAT-SHRINKABLE CABLE 4 C 6-25mm ²	0.090	1
U560-50	JUNCTION 1KV HEAT-SHRINKABLE CABLE 4 C 16-50mm ²	0.195	1
U560-95	JUNCTION 1KV HEAT-SHRINKABLE CABLE 4 C 35-95mm ²	0.300	1
U560-150	JUNCTION 1KV HEAT-SHRINKABLE CABLE 4 C 50-150mm ²	0.400	1
U560-240 4V	JUNCTION 1KV HEAT-SHRINKABLE CABLE 4 C 95-240mm ² 4 SCREWS	1.150	1
U560-300 4V	JUNCTION 1KV HEAT-SHRINKABLE CABLE 4 C 150-300mm ² 4 SCREWS	1.500	1

Option: Sleeve alone



U551-240 4V



U550-150 2V



U550-25 2V

Code	Designation	Weight (kg)	Sales unit
U550-25 2V	MECHANICAL TIGHTENING SLEEVE 6-25mm ² 2 SCREWS	0.020	1
U550-50 2V	MECHANICAL TIGHTENING SLEEVE 16-50mm ² 2 SCREWS	0.045	1
U550-95 2V	MECHANICAL TIGHTENING SLEEVE 35-95mm ² 2 SCREWS	0.070	1
U550-150 2V	MECHANICAL TIGHTENING SLEEVE 50-150mm ² 2 SCREWS	0.095	1
U550-240 2V	MECHANICAL TIGHTENING SLEEVE 95-240mm ² 2 SCREWS	0.200	1
U551-240 4V	MECHANICAL TIGHTENING SLEEVE 95-240mm ² 4 SCREWS	0.280	1
U551-300 4V	MECHANICAL TIGHTENING SLEEVE 150-300mm ² 4 SCREWS	0.350	1

Short-circuiting lost end BPMCC

MICHAUD

Utilisation

This accessory is designed to short-circuit waiting networks without power. It is used to warn accidental powering at one end. It ensures cables watertightness.



BE002

The benefit:

- + Easy installation

Description

- This kit comprises the following accessories:
 - 1 short-circuiting bare connector with mechanical tightening,
 - 1 neutral sheath to cold slide,
 - 2 cold shrinkable ends.

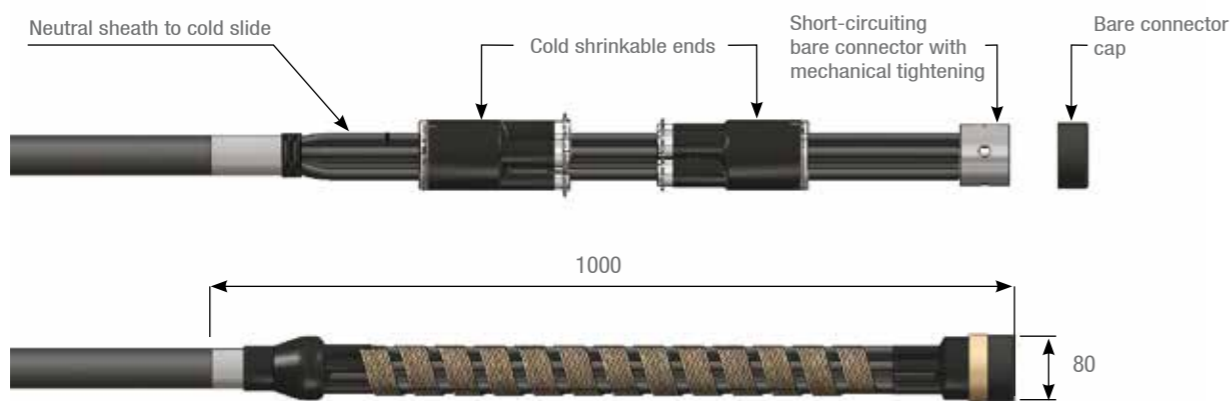

Dimensions in mm

Installation

- Cables preparation.



- Cable re-insulation.

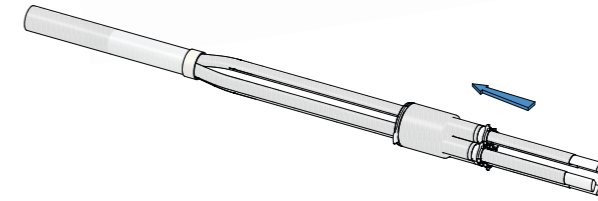

- Conductors short-circuiting.



- Accessory reinforcement.



Code	Désignation	Cable section (mm ²)		Weight (kg)	Sales unit
		Mini	Maxi		
BE002	SHORT-CIRCUITING LOST END BPMCC 50-240	3x95+50	3x240+120M*	1.320	1

* The letter M means that the core of the conductor is solid.

Aerial sub-surface connection for LV network (EJAS)

Phase sleeves and sheaths



Neutral sleeve and sheath



4 outlets end



MIRELEC

Utilisation

Aerial sub-surface junction is designed to establish the connection from an underground network to a low voltage overhead network. They are implemented on overhead environment along a pole, under a mechanical protection as a conduit.

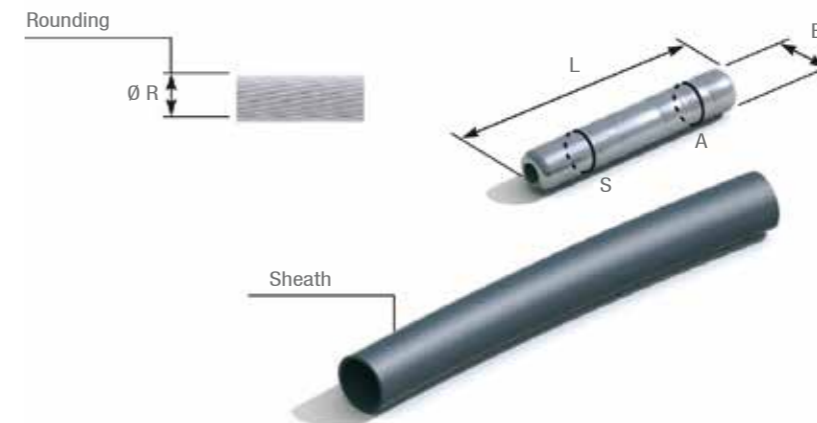

Description

This kit comprises the following accessories:
- 3 phase sleeves and 1 neutral of type MJT,
- 4 heat-shrinkable sheaths for the sleeves insulation,
- 1 end with 4 outlets for the cable head of the underground conductor.

Cable		Sleeve + Sheath		Ø R (mm)	B (mm)	L (mm)	H
S (mm²)	A (mm²)						
50	54.6	MJT 50 - 54	FRM 25 - 200	8.5	20	110	E173
50	70N	MJT 50 - 70N		10.5			
70	54.6	MJT 70 - 54		10.5			
70	70N	MJT 70 - 70N		10.5			
95	54.6	MJT 95 - 54		12			
95	70	MJT 95 - 70		12			
95	150	MJT 95 - 150	FRM 30 - 200	15	25	120	E 215
150	70	MJT 150 - 70					
150	95N	MJT 150 - 95N					
150	150	MJT 150 - 150	FRM 35 - 200	18.5	32	142	E 280
240	70	MJT 240 - 70					
240	150	MJT 240 - 150					

Code	Designation	Cable (mm²)		Set composition		Weight (kg)	Sales unit
		Underground	Overhead	Sleeve	Sheath		
U580	EJAS 95 - 50/70-54	3x95+50	3x70+54.6	MJTASE 95-70 1 MJT 50-54	3 FRM 30 - 200	0.520	1
U581	EJAS 95 - 50/70-70N	3x95+50	3x70+70N	MJTASE 95-70 1 MJT 50-70N	1 FRM 25 - 200	0.510	1
U582	EJAS 95 - 50/150-70N	3x95+50	3x150+70N	MJTASE 95-150 1 MJT 50-70N	4 FRM 25 - 200	0.680	1
U583	EJAS 95 - 70/70-54	3x95+70	3x70+54.6	MJTASE 95-70 1 MJT 70-54	3 FRM 30 - 200 1 FRM 25 - 200	0.640	1
U584	EJAS 150 - 70/70-70N	3x150+70	3x70+70N	MJTASE 150-70 1 MJT 70-70N	3 FRM 30 - 200 1 FRM 25 - 200	0.670	1
U585	EJAS 150 - 70/150-70N	3x150+70	3x150+70N	MJTASE 150-150 1 MJT 70-70N	3 FRM 30 - 200 1 FRM 25 - 200	0.720	1
U586	EJAS 240 - 95/70-54	3x240+95	3x70+54.6	MJTASE 240-70 1 MJT 95-54	3 FRM 35 - 200 1 FRM 25 - 200	0.810	1
U587	EJAS 240 - 95/70-70N	3x240+95	3x70+70N	MJTASE 240-70 1 MJT 95-70N	3 FRM 35 - 200 1 FRM 25 - 200	0.840	1
U588	EJAS 240 - 95/150-70N	3x240+95	3x150+70N	MJTASE 240-150 1 MJT 95-70N	3 FRM 35 - 200 1 FRM 25 - 200	0.920	1

REMIC set of bars



Set of bars 300
Q 600



Set of bars 450
Q 601



Set of bars 600
Q 602

MICHAUD

Application

The sets of bars supports 300, 450 and 600 respectively offer 6, 9 and 12 connection terminals for each pole.

Description

- The sets of bars supports 300, 450 and 600 are respectively made of 6, 9 and 12 steps of 50mm.
- The set of bars support is fixed to the bottom of all REMBT cabinets on standardised inserts.
- The inclination of the phase bars facilitates connection.
- The poles are identified (N, L1, L2, L3).
- The modules are fixed using standardised M12 threads.
- The product is IP2X before and after installation. The unused connection terminals are covered using a captive cap.
- A 400A re-supply device can be connected directly to the connection terminals. IP2X is maintained thanks to the 35mm diameter of the terminals.

These sets of bars supports meet the criteria of the **HN 63-S-65** standard.

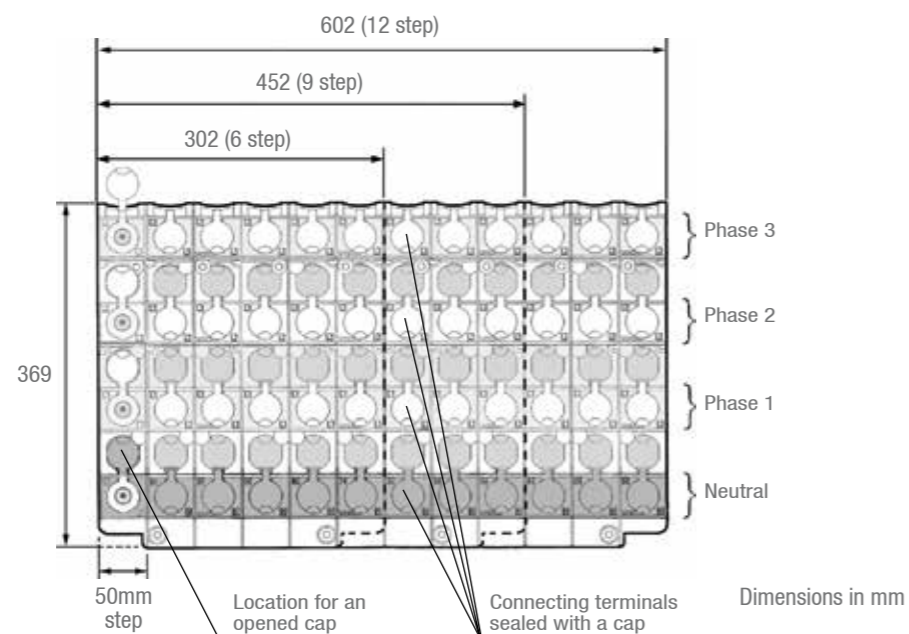

Code	Designation	Weight (kg)	Sales unit
Q600	REMIC SET OF BARS SUPPORT 300	2.630	1
Q601	REMIC SET OF BARS SUPPORT 450	3.760	1
Q602	REMIC SET OF BARS SUPPORT 600	4.870	1

Accessories

ADAPTORS FOR S15-S20 CABINETS

Code	Designation	Weight (kg)	Sales unit
Q618	REMIC STANDARD S20 CABINET FRAME	1.030	1
Q619	REMIC STANDARD S15 CABINET FRAME	1.550	1



REMIC service module

Fuse module

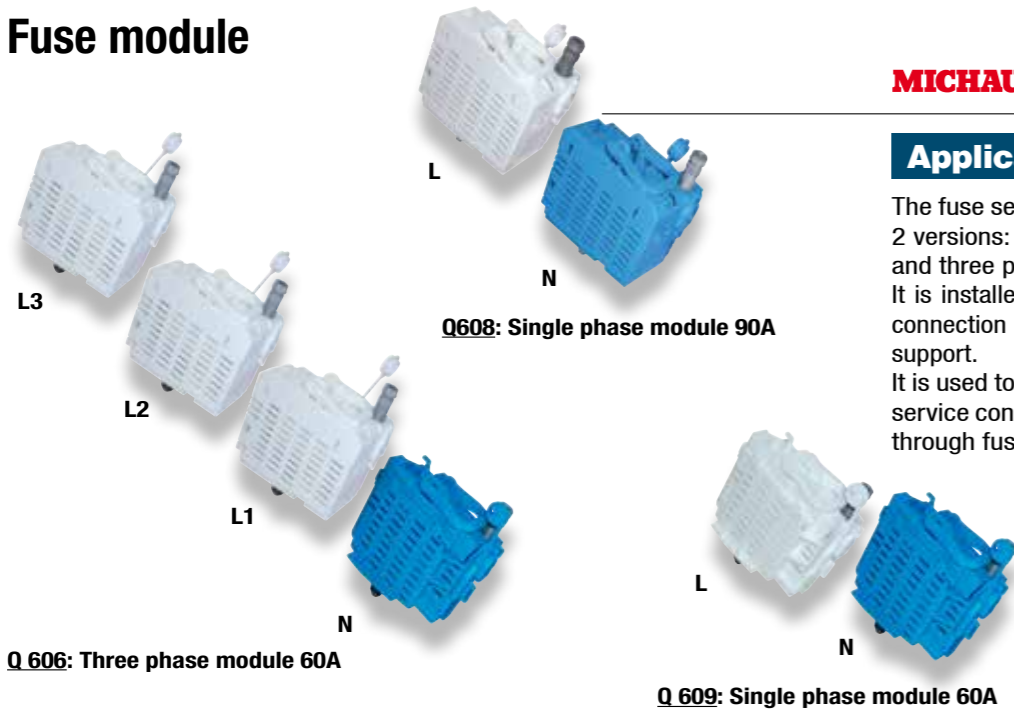

MICHAUD

Application

The fuse service module is available in 2 versions: single phase 60A and 90A, and three phase 60A. It is installed on the M12 standardized connection terminals of the set of bars support. It is used to tap a single or three phase service connection ensuring protection through fuses size 00.

Q 606: Three phase module 60A

Q 609: Single phase module 60A

The benefit:

+ In case of long service connections, the terminal can receive 50M solid core to avoid voltage drop.

Description

- The fuse service module has a protection degree type IP2X before and after installation.
- The neutral is identified thanks to its blue colour.
- The connection terminals use insulation piercing technology and are equipped with shear head screws. Capacity is 10-25mm² Cu / 16M-50M Al (the letter M means that the core of the conductor is solid).

This module meets the criteria of the **H 63-S-65** standard.

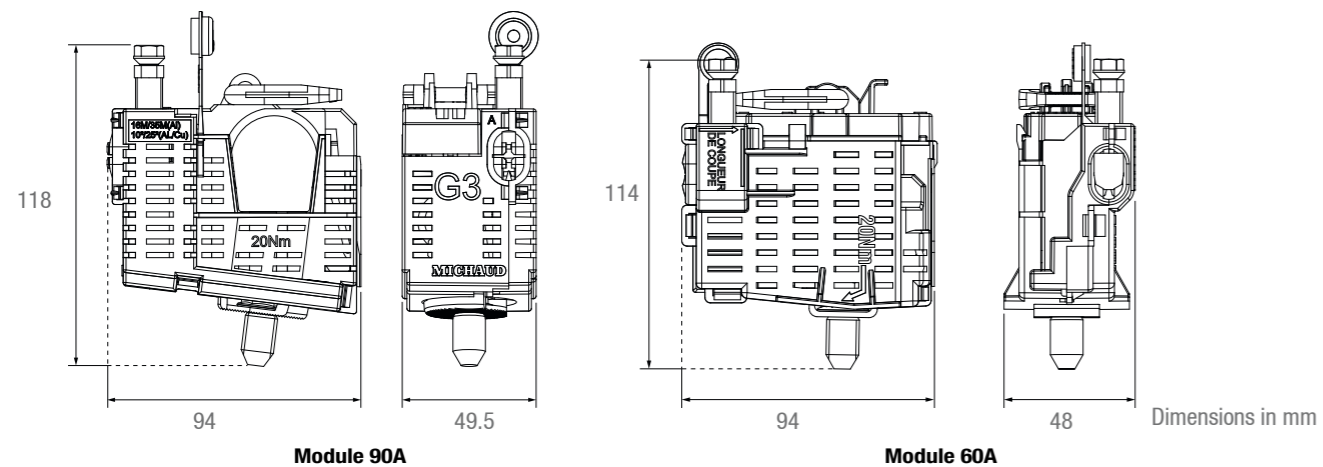

Code	Designation	Normative capacity (A)	Real capacity (A)	Weight (kg)	Sales unit
Q608	REMIC MODULE TYPE FUSE SERVICE SINGLE PHASE 90A RBPM	90	108	0.590	1
Q606	REMIC MODULE TYPE FUSE SERVICE THREE PHASE 60A RBPT	60	72	0.850	1
Q609	REMIC MODULE TYPE FUSE SERVICE SINGLE PHASE 60A RBPM	60	72	0.430	1

Multitap module

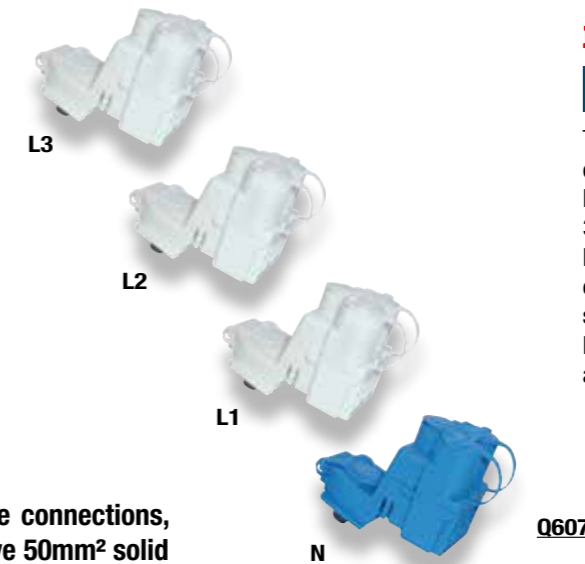

MICHAUD

Application

The multitap connection module comprises 1 neutral and 3 phases. It allows a maximum of 3 single phase or 3 three phase services to be connected. It is installed on the M12 standardized connection terminals of the set of bars support. It is mainly used when the AD fuses are installed in the customer premises.

The benefit:

+ In case of long service connections, the terminal can receive 50mm² solid core to avoid the voltage drop.

Description

- The multitap connection module has a degree of protection type IP2X before and after installation.
- The neutral and phases have 3 insulation piercing connection terminals.
- The neutral is identified thanks to its blue colour.
- The terminals are equipped with shear head screws. Capacity is 10-25mm² Cu / 16M-50M Al (the letter M means that the core of the conductor is solid).
- The product design allows the conductors to be wired on the top of the lower terminals.
- The small size of the IP2X caps provides access to the tightening screws of the terminals even when all of the conductors are connected.

This module meets the criteria of the **HN 63-S-65** standard.

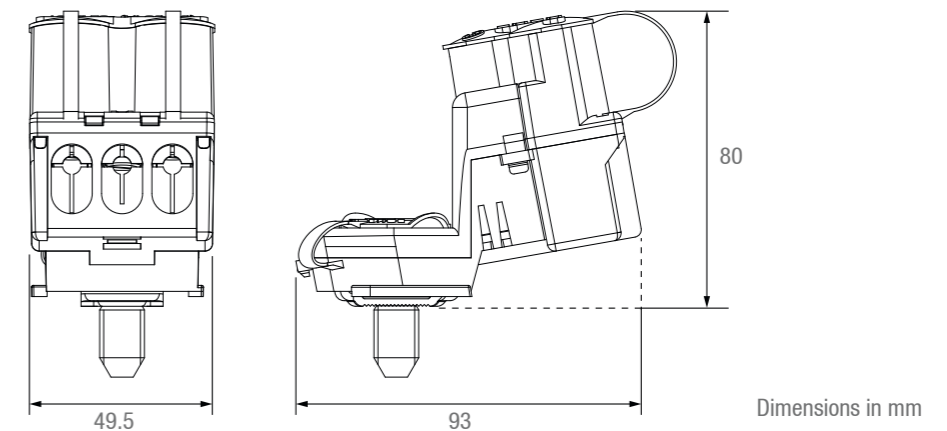

Code	Designation	Weight (kg)	Sales unit
Q607	REMIC MULTITAP CONNECTION MODULE RBD (1 NEUTRAL + 3 PHASES)	0.950	1

Variant:

The multitap connection module is available in single phase version.

Code	Designation	Weight (kg)	Sales unit
Q610	REMIC MULTITAP CONNECTION MODULE SINGLE PHASE (1 NEUTRAL + 1 PHASE)	0.580	1

REMIC network module

MICHAUD

Application

The network module is available in 2 versions:
- 50-240mm²,
- 50-150mm².
It comprises one neutral terminal and three phase terminals.
It is installed on the M12 standardized connection terminals of the sets of bars supports.

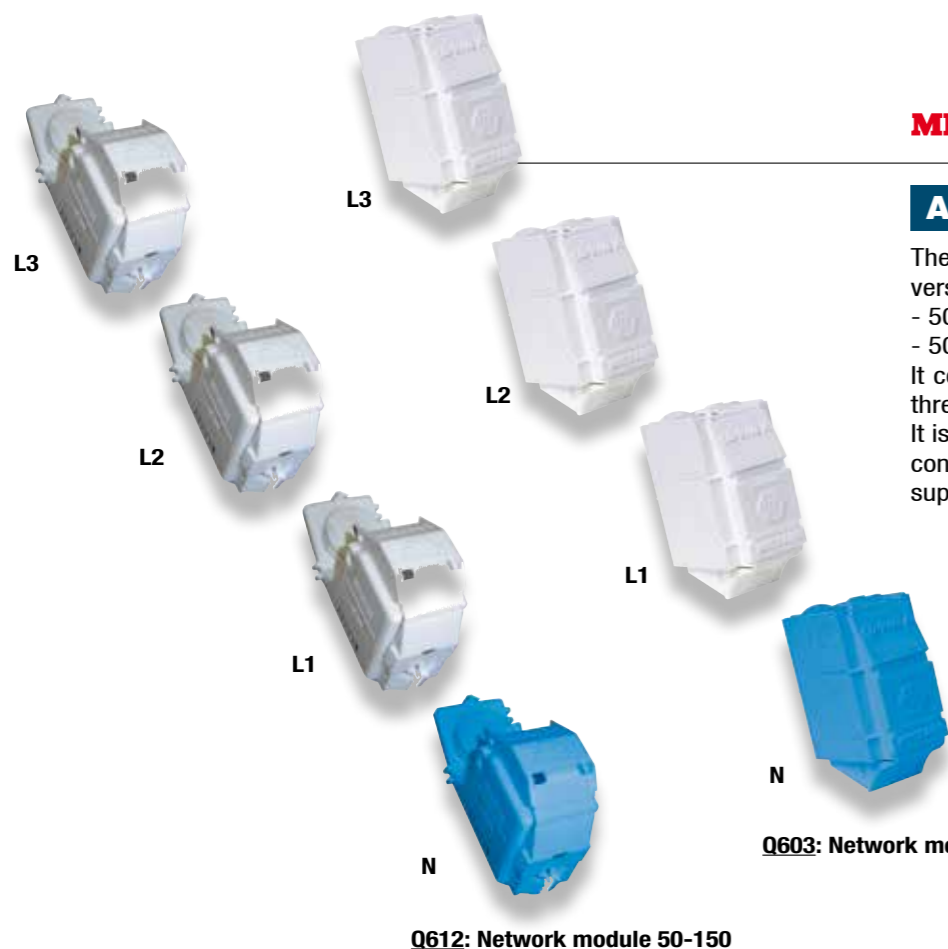

Q603: Network module 50-240

Q612: Network module 50-150

The benefits:

- + Easy installation of the NETWORK module 50-240.
- + 50mm² or 95mm² connection on a terminal of the NETWORK module 50-150.

Description

- The terminals are of Class A according to the **NF C 63-061** standard (Electrical ageing: 700 cycles).
- They are IP2X before and after installation regardless of the conductors section.
- The neutral is identified thanks to its blue colour.
- The terminals receive round or sectoral shape aluminium or copper conductors.
- The conductors are tightened using a hexagonal H14 shear head screw. A second H14 head is used for possible dismantling and reuse using a 40Nm torque wrench.

This module meets the criteria of the **HN 63-S-65** standard.

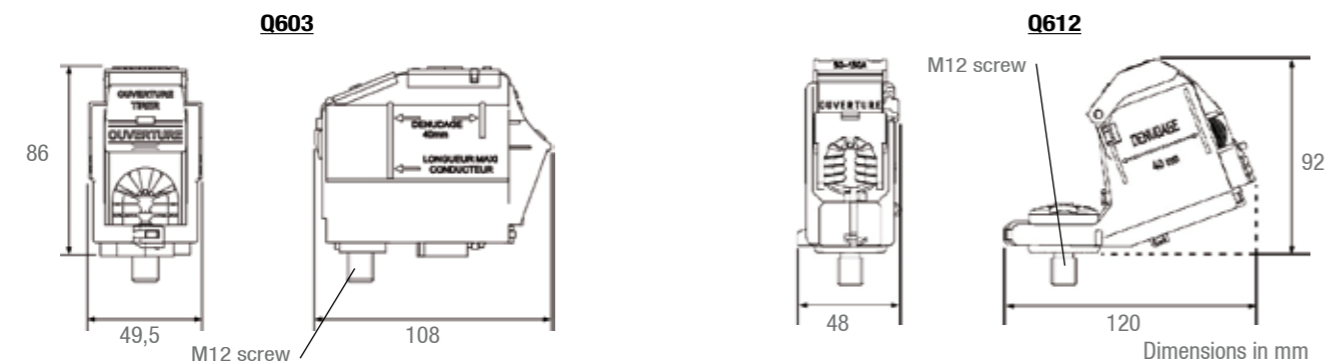

Installation

PRINCIPLE

- For all cable sections
Install the network module on two 50mm steps. The design of the set of bars supports allows one or the other of the configurations besides.

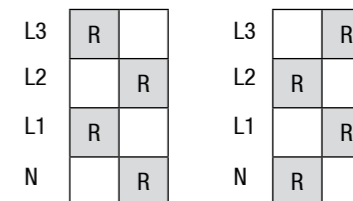

R = Network terminal

- For the cables with sections up to 95mm²
The network module 50-150 can be installed on only one step.

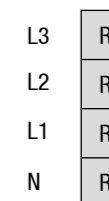

CHRONOLOGY OF THE OPERATIONS

- For the 50-240 module



1°) Fixing of the module to the set of bars support (tightening at 30Nm).

2°) Moving the **captive** slide of the module to the top so the conductor can be grasped from the front.

3°) Tightening of the conductor until the shear head breaks after bringing the upper part of the terminal back to the bottom.

- For the 50-150 module

The principle is the same except the fact that the slide of the terminal does not have a retention system in the upper part (the slide is installed and removed from the front).

Code	Designation	Weight (kg)	Sales unit
Q603	REMIC MODULE TYPE NETWORK RRD 50-240 (1 NEUTRAL + 3 PHASES)	1.780	1
Q612	REMIC MODULE TYPE NETWORK RRD 50-150 (1 NEUTRAL + 3 PHASES)	1.670	1

Accessory

The insulation bloc module enables a network module to be temporarily separated from the set of bars support and possibly resupplied.

This module meets the criteria of the **HN 63-S-65** standard.

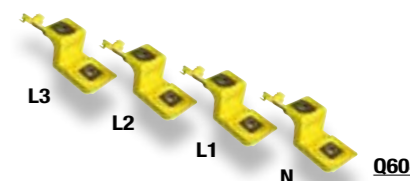

Code	Designation	Weight (kg)	Sales unit
Q604	REMIC 4-TYPE INSULATION BLOC MODULE	0.668	1

REMIC disconnection and protection module RRCP



Q614

MICHAUD

Application

The REMIC module type RRCP offers a network outlet that can be cut (400 A function) or protected using maximum 200A fuses 115mm size 2 (200A function).
It is installed on the M12 standardised connection terminals of the sets of bars supports.
It is mainly used for supplying a collective or individual service with supervised power.

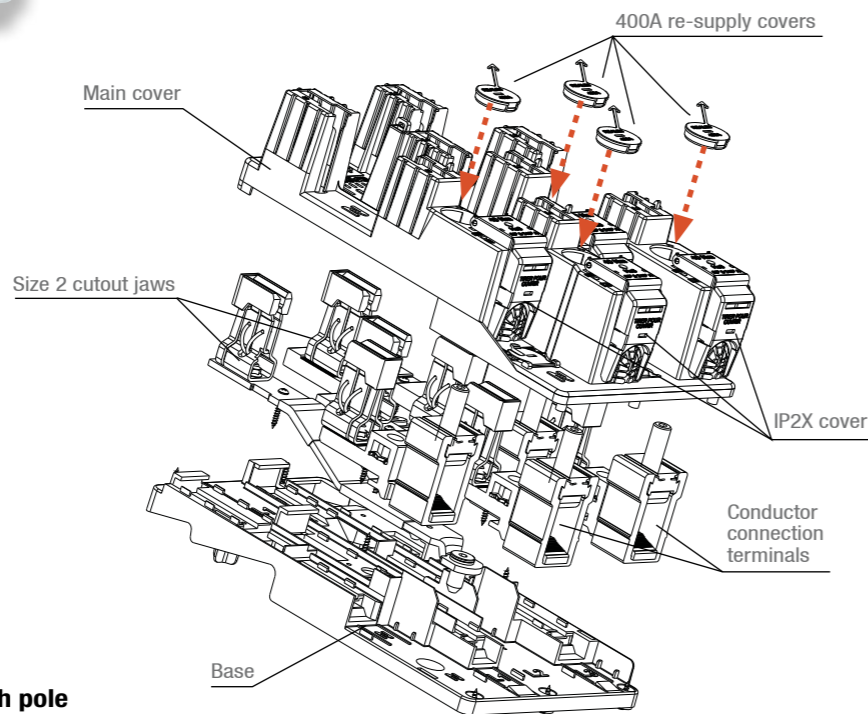

The benefits:

- + 1 single tool for installation
- + Compatibility with flat doors
- + Clear poles separation
- + Integrated IP2X protection on each pole

Description

- The small thickness of the new generation of module type RRCP facilitates use in small depth cabinets (flat door).
- The neutral is identified thanks to its blue colour.
- The terminals allow the connection of round or sectoral shape, copper or aluminium conductors.
- The capacity of the terminals is 50 to 240mm² for the neutral and for the phases.

This module meets the criteria of the **HN 63-S-65** standard.

Caution: the RRCP module is installed exclusively on REMIC sets of bars supports.

Installation

PRINCIPLE

A disconnection and protection module (RRCP) requires four 50mm steps.

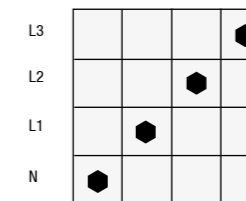

● : Fixing points on the set of bars support

CHRONOLOGY OF THE OPERATIONS

ASSEMBLY

- On the set of bars supports installed (450 or 600), open the 4 poles diagonally in the required place for installing the RRCP (the other captive caps above and below the diagonal must remain closed).
- Remove the IP2X captive caps then place and fix the RRCP on the set of bars support using 4 H16 screws.
- Replace all of the captive caps while waiting connection of the outlet.

LEADING-OUT WIRING

- Prepare end cable as usual.
- Remove the covers of the terminal blocks to connect.
- Cut the conductors to length, strip them over 45mm, brush them with neutral grease then insert them into the terminals.
- Replace the slides in U shape and tighten the screws until 40Nm.
- Replace the covers.

INSTALLATION OF THE BARS OR FUSES SIZE 2 (CENTRE-TO-CENTRE DISTANCE 115mm)

- Install the links or fuses using an insulated operating handle.

INSTALLATION OF THE RE-SUPPLY

- Remove the 4 re-supply covers.
- Perform necessary electrical measurements.
- Insert and screw the M12 re-supply socket.



Code	Designation	Weight (kg)	Sales unit
Q614	REMIC MODULE RRCP 400A / 200A	5.658	1

Variation:

The ERDF technical specification also defines a product known as RRC exclusively dedicated to the 400A cutout. For Michaud this is exactly the same product.

Code	Designation	Weight (kg)	Sales unit
Q613	REMIC MODULE RRC 400A	5.658	1

Protection and warning

Protection plate roll (PPR)

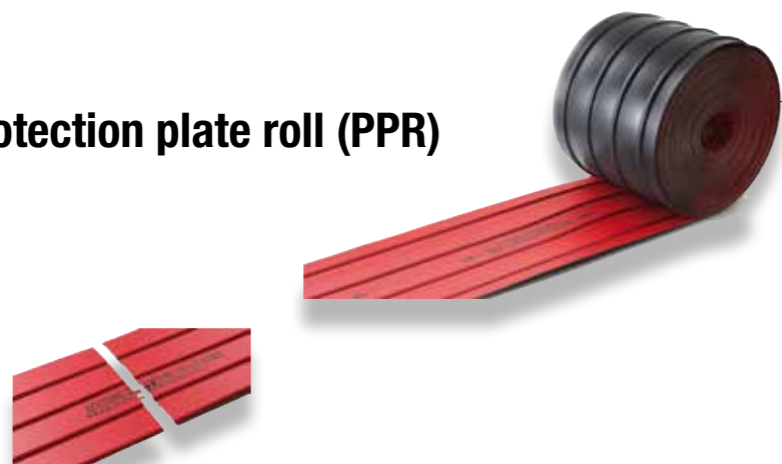

MICHAUD

Application

This protection plate roll (PPR) is designed to protect underground networks from extraction (pipes and/or cables). It can be used for underground network under weak load, engineering structure crossing, or in area of high density network.

Description

- The plate roll offers permanent mechanical protection.
- It is rot-proof, corrosion and water resistant and shock absorbing.
- The plate is of red colour. Other colours are available upon request.

This protection plate roll meets the criteria of the **DIN 54841-5** standard.

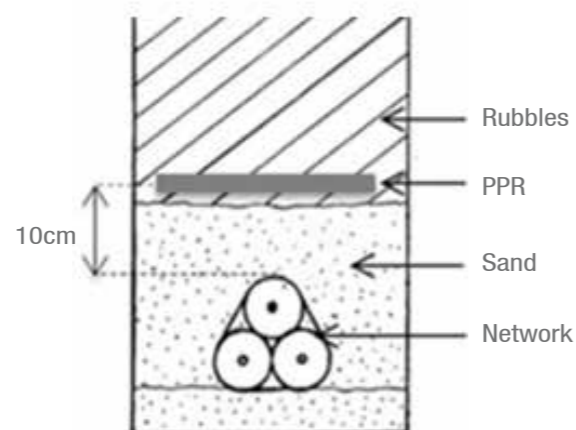

Code	Designation	Dimensions LxHxD (mm)	Weight (kg)	Sales unit
U591	PROTECTION PLATE ROLL (width 160mm)	50 000 x 160 x 2	16	1
U592	PROTECTION PLATE ROLL (width 180mm)	50 000 x 180 x 2	18	1
U593	PROTECTION PLATE ROLL (width 240mm)	25 000 x 240 x 2	12	1
U594	PROTECTION PLATE ROLL (width 300mm)	25 000 x 300 x 2	15	1

Other colours are available, please contact us.

Warning netting



MIRELEC

Application

This warning netting is designed to indicate the presence of low voltage power line cables buried in the ground.

Description

- This warning netting is available in 3 widths: 100, 200 and 300mm.
- It is made of red or green synthetic materials according to the requirement.

This flexible netting meets the criteria of the **NF EN 12613** standard.

Code	Designation	Width (m)	Length (m)	Weight (kg)	Sales unit
F860	WARNING NETTING 300m (width 0.1m)	0.1	300	1.500	3
F861	WARNING NETTING 100m (width 0.2m)	0.2	100	1.100	1
F862	WARNING NETTING 100m (width 0.3m)	0.3	100	1.625	1

Cold shrinkable seal

E2R RF - E4R RF cable sealing end



E4R RF 95-240
L103



E4R RF 35-70
L102



E4R RF 10-35
L101



E2R RF 10-35
L100

MICHAUD



Application

This cable sealing end is designed to ensure the watertightness of network and service stripped conductors ends. It is slid on the conductors and implemented without using flame.

The benefits:

- + No tool is required
- + Very short installation time

Description

- Cable sealing ends are made of elastomer materials very elastic, flexible, resistant and treated to ensure a good protection to UV.
- For 2 conductors :
 - Service cable of 10 up to 35mm² (L100),
- For 4 conductors :
 - Service cable of 10 up to 35mm² (L101),
 - Network cable of 35 up to 70mm² (L102),
 - Network cable of 95 up to 240mm² (L103).

Installation

- Clean and strip the cable over the appropriate length.
- Remove the cable screen as well as stockings and clean each conductor.
- Cover the cut with three turns of adhesive tape.
- Re-insulate the neutral using a re-insulation sheath.
- Slide the cable sealing end up to the stop on the cable side (1).
- Remove the applicator ring on the cable side (2).
- Remove successively applicator rings on each conductor (3).

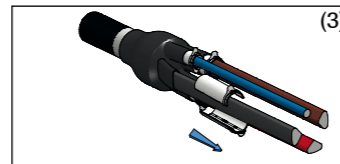
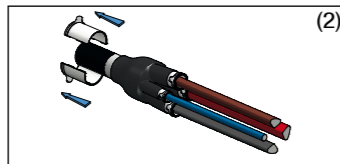
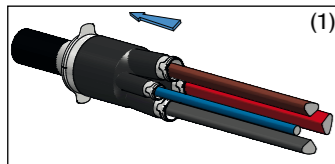

Code	Désignation	Capacity** (mm ²)	Weight (kg)	Sales unit
L100	CABLE SEALING END E2R RF 10-35 SILICONE	2x10 up to 2x35	0.050	20
L101	CABLE SEALING END E4R RF 10-35 SILICONE	4x10 up to 4x35	0.075	20
L102	CABLE SEALING END E4R RF 35-70 SILICONE	4x35 up to 4x70	0.100	20
L103	CABLE SEALING END E4R RF 95-240 SILICONE	3x95 + 50/70M* up to 3x240 + 95/120M*	0.130	10

* M means that the conductor core is solid.

** Capacities according to NF standards.

Cable cap



CRC RF 46-80
L115



CRC RF 26-48
L114



CRC RF 16-27
L113



CRC RF 8-16
L112

MICHAUD

Application

This cap is designed to ensure the watertightness of network and service cables conductors end. It can be used on cable drums. It is used exclusively without power.

The benefits:

- + No tool is required
- + Very short installation time



Installation video available on www.michaud-export.com
(tab Documentation > Installation videos)

Description

- Cable caps are made of elastomer material very elastic, flexible, resistant and treated to ensure a good protection to UV.
- Cable caps are available in 4 dimensions:
 - For service cable of 1.5 up to 10mm² (L112),
 - For service cable of 16 up to 35mm² and peripheral three phase neutral (L113),
 - For network cable of 50 up to 150mm² (L114),
 - For network cable of 240mm² (L115).

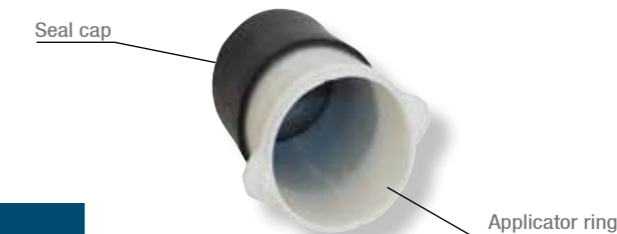

Installation

- Make sure that the cable end is cleanly cut. If not, cut it again (1).
- Put the seal cap on the conductor end (2).
- Remove the applicator ring until total cap shrinking on the conductor (3).



Code	Désignation	Capacity (mm ²)	Covered diameter (mm)	Weight (kg)	Sales unit
L112	SEAL CAP CRC RF 8-16	2x1.5 up to 2x10 or 4x1.5 up to 4x6	8 to 16	0.026	10
L113	SEAL CAP CRC RF 16-27	LV: 4x16M* up to 4x35M*	16 to 27	0.050	10
L114	SEAL CAP CRC RF 26-48	LV: 4x50 up to 3x150 + 95M* HV: 50 up to 240	26 to 48	0.070	10
L115	SEAL CAP CRC RF 46-80	LV: 3x240 + 120M* HV: 630 up to 1200	46 to 80	0.102	10

* M means that the conductor core is solid.

Housing



Housing

Smart Meter Equipment

Universal meter board and accessories	p.190
Meter circuit-breaker board	p.192
AMM concentrator data supply kit	p.194
Modular distribution box	p.196
Cutout cabinet	p.198
Seal	p.200

Universal flexible linking cable

Insulation piercing end connector EBCP 6-35	p.202
Insulation piercing end connector EBCP 16-50 Class II	p.204
Reversible stripping end connector EBCD 6-35	p.206
Flexible linking cable	p.208
Reducing end connector	p.210



Specialised in electrical distribution, MICHAUD develops its expertise with the arrival of Smart Meter, offering solutions for the counting environment and protection.



Evolution in the housing field: Smart Meter

Due to the evolution of european specifications for **Smart Meter systems**, it is necessary to assist meters manufacturers or distribution networks operators.

The Smart Meters roll out requires an adaptation of residential installations. MICHAUD invests to make the change easier by developing solutions **suited for current installations and ready to receive new counting solutions.**

Thanks to its expertise and engineering, MICHAUD proposes **custom-made solutions** to better suit the project.

The benefits

-  Anticipate and facilitate transition towards Smart Meter
-  Reduce intervention time as well as electricity supply cut time
-  Minimise roll-out cost

Adaptation to new counting systems

In this scalable environment, the development of **universal solutions** enables better preparation for change according to evolution of Smart Meter technology.

Thanks to its skills and its expertise, MICHAUD was a pioneer regarding the design of insulation piercing end connector. It is a solution for universal connection between service cable and board terminals enabling to realise safe connection between aluminium and copper.

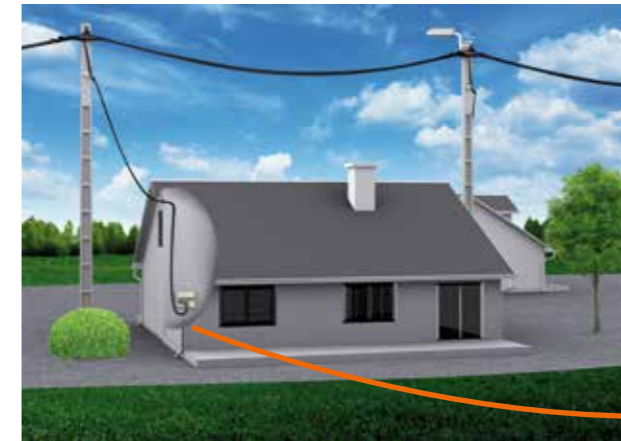

Characteristics

Connection between the aluminium service cable and the copper board terminal.

Cable tail flexibility and small end connector bulk.

Possible tail extension.

Assets

- + No electrolytic corrosion phenomenon
- + Easier fitter work in confined space
- + Easy renovation

Available end connectors types

Type	Normative rating
Insulation piercing end connector EBCP 6-35 <small>EBCP: Insulation piercing end connector</small>	EBCP 6-35/16 — Tail section (16 or 25) <small>Leading-in conductor mini and maxi capacity</small>
Insulation piercing end connector EBCP 16-50 <small>Leading-in conductor minimum section</small>	16 - 50 SECT — Sectoral or round shape of leading-in conductor <small>Leading-in conductor maximum section</small>
Reversible stripping end connector EBCD 6-35 <small>EBCD: Reversible stripping end connector</small>	EBCD 35-25 — Tail section <small>Leading-in connector maximum section</small>

Universal meter board and accessory



K424

MICHAUD

Application

This meter board is used to receive any residential type electric meter whether single phase, three phase or tetrapolar, equipped with a cable cover. It can be combined with pluggable or non-pluggable module type connection equipment.

Description

- The assembly is made of grey synthetic self-extinguishing materials (RAL 9035).
- The board is equipped with a removable clipped cover which is dismantable to make equipment wiring easier.
- The board is vertically fixed to a flat surface and possibly by means of alignment laths (see Accessories).
- When equipped with a tetrapolar meter, the board is IP4X on the front face and IK4.

The board is used to fix meters that meet the criteria of the **DIN 43857** standard.

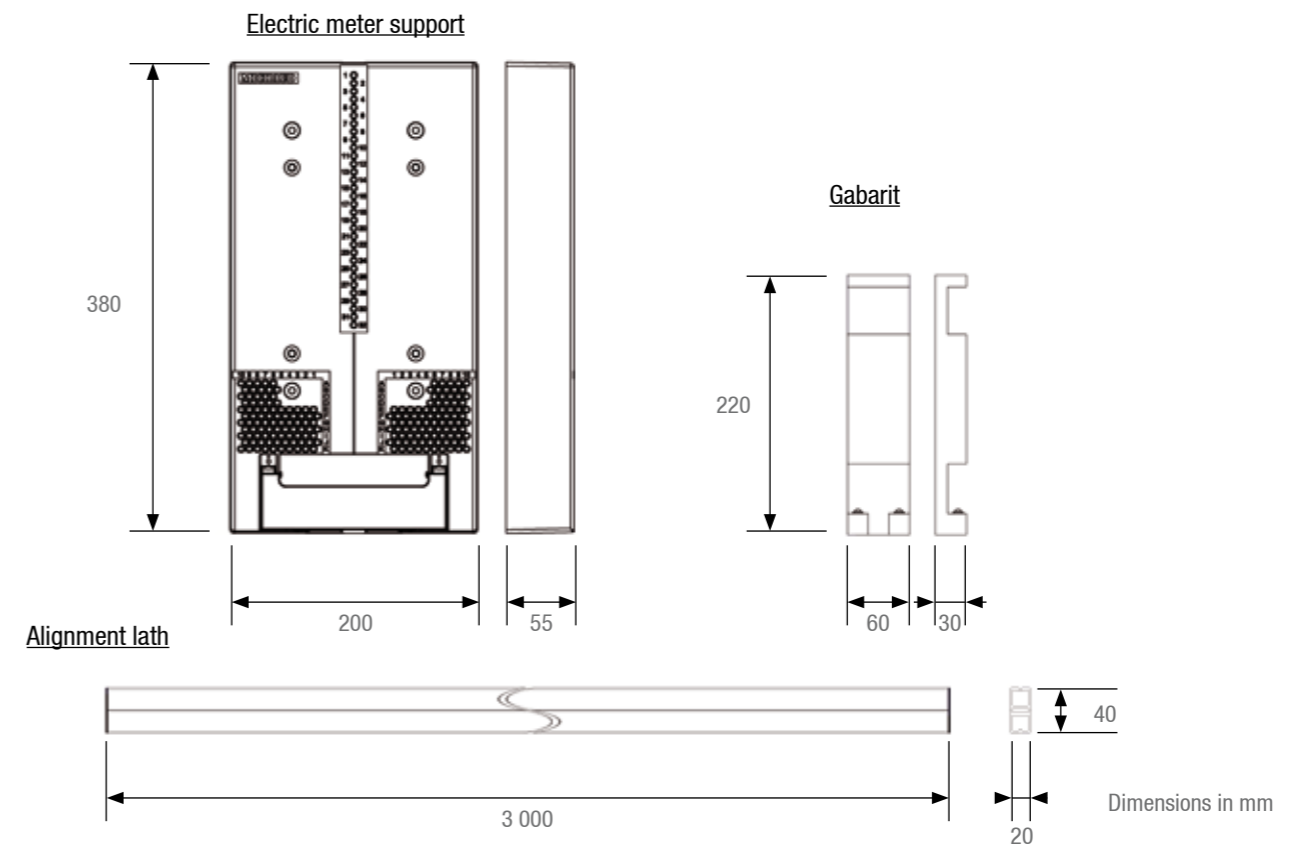
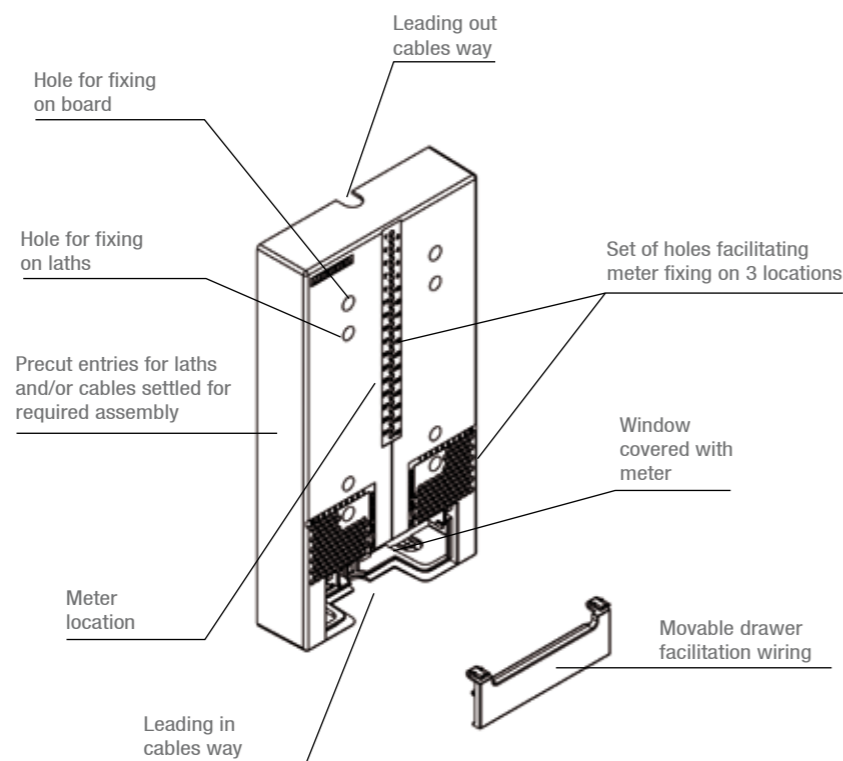

Code	Designation	Weight (kg)	Sales unit
K424	SUPPORT FOR ELECTRIC METER + COVER	0.500	240
K425	COVER (FOR ELECTRIC METER SUPPORT)	0.080	1

Accessories

Code	Designation	Weight (kg)	Sales unit
K422	ALIGNMENT LATH (Length 3m)	1.500	270
K421	GABARIT FOR ALIGNMENT LATH	0.320	1

Comment: if the supporting wall is uneven, the meter board can be mounted using alignment laths. The laths are made from grey PVC. The gabarit makes it easier to assemble the laths and guarantee a centre-to-centre distance of 150mm between laths.

Installation

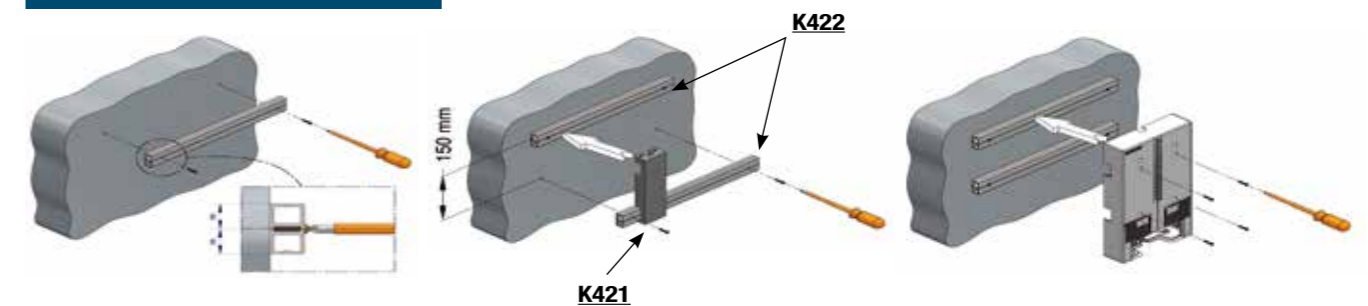

Housing

Housing

Meter circuit-breaker board



P475



P474

MICHAUD

Application

This board is designed to accommodate the single phase electronic meter and the circuit-breaker. It defines the boundary between the energy distributor and the installer private domain. The cover is optional.

Description

- The assembly is made of white synthetic self-extinguishing materials (RAL 9010).
- The front face is equipped with a fixing rail for installing the meter and windows for conductors to run through. It can be dismantled for easier wiring of the devices. The rail can be removed for installing the meter.
- The board is equipped with connectors fixed to the bottom, designed to receive the leading-in cables from the top or the bottom. The terminals use insulation piercing technology and shear heads.
- Connectors have a IPXXB protection degree after installation. The system integrates 16mm² copper links which length enables the connection of any meters with terminals at the top or bottom.
- The terminals downstream of the circuit-breaker are accessible via a drawer in the lower part.
- The meter board can be covered with the P474. The cover is equipped with a board fixing to be attached on the board and a swivel window on the front face to access the meter and circuit breaker.

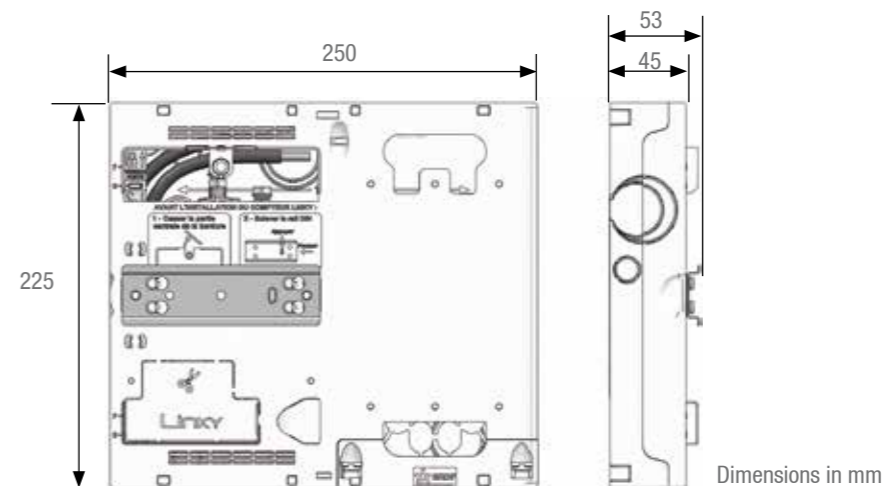
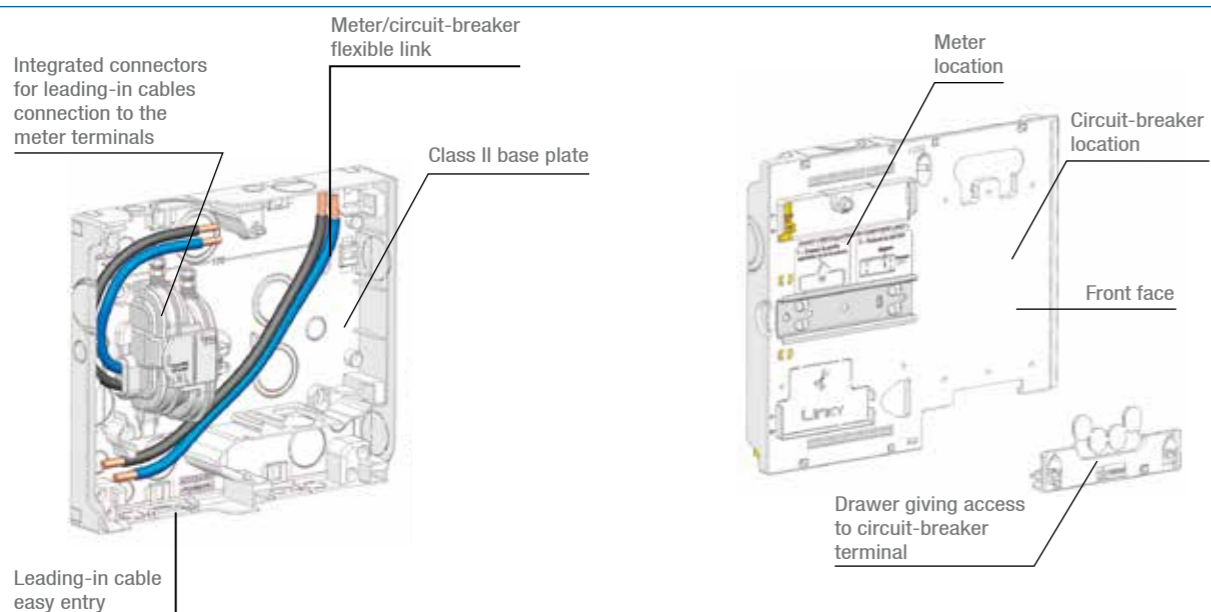

Code	Designation	Weight (kg)	Sales unit
P475	METER AND CIRCUIT-BREAKER BOARD	0.920	1
P474	COVER FOR METER AND CIRCUIT-BREAKER BOARD	0.340	1

Variants:

Meter circuit-breaker board for three phase electronic meter.



Code	Designation	Weight (kg)	Sales unit
R092	250x550 PANEL FOR THREE PHASE METER + CIRCUIT-BREAKER + COVER	3.080	1
R041	250x550 PANEL FOR THREE PHASE METER + CIRCUIT-BREAKER WITHOUT LOGO	1.920	1
R112	COVER FOR 250x550 PANEL	1.160	1
R043	330x330 PANEL FOR THREE PHASE METER + CIRCUIT-BREAKER WITHOUT LOGO	2.500	1
R139	COVER FOR 330x330 PANEL	1.200	1

AMM concentrator data supply kit



MICHAUD

Application

This kit is designed for the installation of an AMM (Automatic Meter Management) data concentrator in a LV/MV transformer or on a pole depending on the type of network (underground or overhead). These products supply and protect the concentrator.



Description

To facilitate the use and management, these products are supplied in packs:

For LV/MV underground stations: Pack Alim L6000 + AMM station connector board

This pack comprises the following elements:

- 1 AMM station concentrator board (P070) of dimensions 377x281 equipped with:
 - 1 DIN rail on which a three phase cutout is fixed
 - 4 links 2.5mm² for the cutout and concentrator connection through a pluggable service end.
The concentrator board is delivered with 3 fuses cartridges size 10.3x38, gauge 2A, a neutral tube and 3 screws pre-screwed on the connector board ensuring the concentrator fixing.
- 1 AMM concentrator data supply kit L=6M (K716) or L=10M (K719) comprising:
 - 3 phase connectors and 1 neutral insulation piercing connector with integrated removable fuse protection (3P+1N), 3 fuses size 10x38, rated 10A and a neutral tube.
 - 1 connection link of 6 or 10 meters (depending on the type) between connectors and the concentrator board cutout. It is equipped with quick connection plug on the connectors side end.

Installation

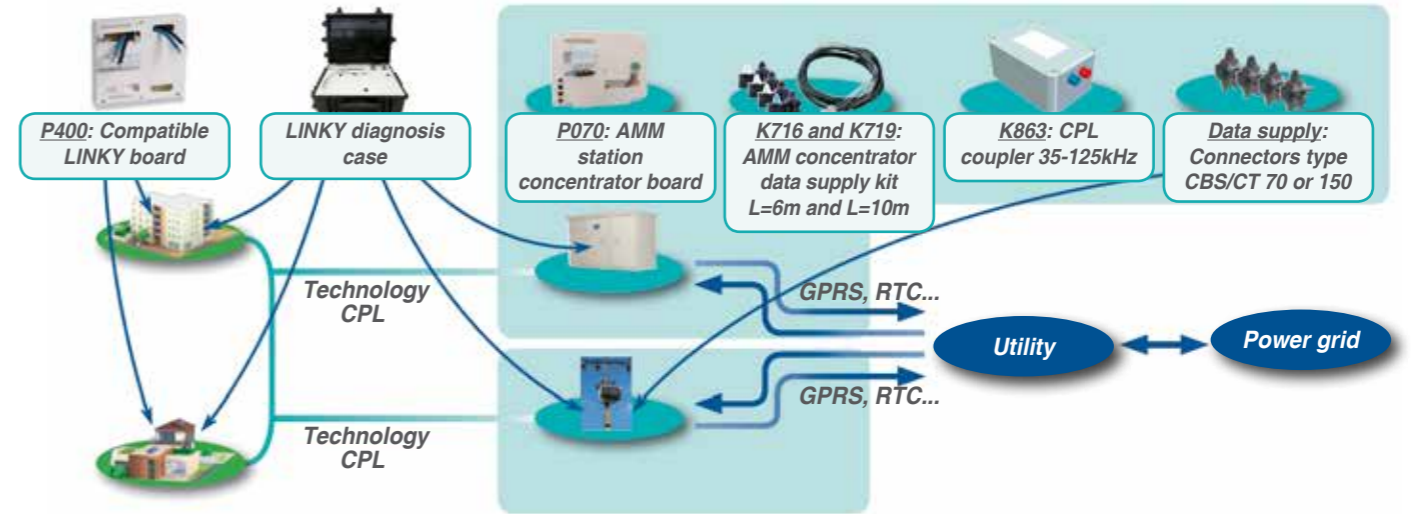

* LINKY: French electricity board Erdf electronic Smart Meter.
For the references P400 and K863, contact us.

Code	Designation	Weight (kg)	Sales unit
K716	AMM CONCENTRATOR DATA SUPPLY KIT + LINKING CABLE L=6m	2.000	1
K719	AMM CONCENTRATOR DATA SUPPLY KIT + LINKING CABLE L=10m	2.400	1
P070	AMM STATION CONCENTRATOR BOARD	1.350	1

Accessories

SEE SHEET
OVERHEAD / Service connector

Modular distribution box

Projecting



MICHAUD

Application

This one row modular distribution box is designed to be equipped with devices that protect the customer installation.

Description

- The assembly is made of synthetic materials passing the incandescent wire resistance test at 750°C.
- The cover is white (RAL 9010) and offers a IP30/IK05 protection degree.
- The distribution boxes with 6 and 9 modules are delivered with an IP2X earth system terminal offering 7 inlets/outlets including connection terminals of 16mm² section maximum.
- The distribution boxes with 1 up to 6 modules can be opened using a clip. The distribution box with 9 modules uses screws.

This distribution box meets the criteria of the **NF C 61-910** specification.

Code	Designation	Height (mm)	Length (mm)	Depth (mm)	Weight (kg)	Sales unit
Q591	DISTRIBUTION BOX WITH 1 MODULE	140	30	70	0.080	1
Q592	DISTRIBUTION BOX WITH 2 MODULES	141	48	70	0.100	1
Q594	DISTRIBUTION BOX WITH 4 MODULES	142	84	70	0.140	1
Q596	DISTRIBUTION BOX WITH 6 MODULES	180	120	70	0.250	1
Q599	DISTRIBUTION BOX WITH 9 MODULES	180	190	70	0.360	1

Integrable



MIRELEC

Application

This integrable modular distribution box is designed to be equipped with devices that protect the customer installation.

Description

- Several box widths are available: 8, 12, 24 (2 rows of 12) and 36 (3 rows of 12) modules.
- The cover is white and the door is transparent.
- The opening and closing system is ergonomic and the door is reversible.
- The distribution box offers IP40 protection degree (protection against penetration of body superior or equal to 1mm).
- The use temperature range goes from -25°C up to 60°C.
- Used materials are without halogen.

Code	Designation	Height (mm)	Length (mm)	Depth (mm)	Weight (kg)	Sales unit
U635	INTEGRATED MODULAR BOX - 8 MODULES	90	240	90	0.485	20
U636	INTEGRATED MODULAR BOX - 12 MODULES	260	330	90	0.825	12
U637	INTEGRATED MODULAR BOX - 24 MODULES (12x2)	420	330	100	1.655	10
U638	INTEGRATED MODULAR BOX - 36 MODULES (12x3)	570	330	100	2.325	10

Cutout cabinet

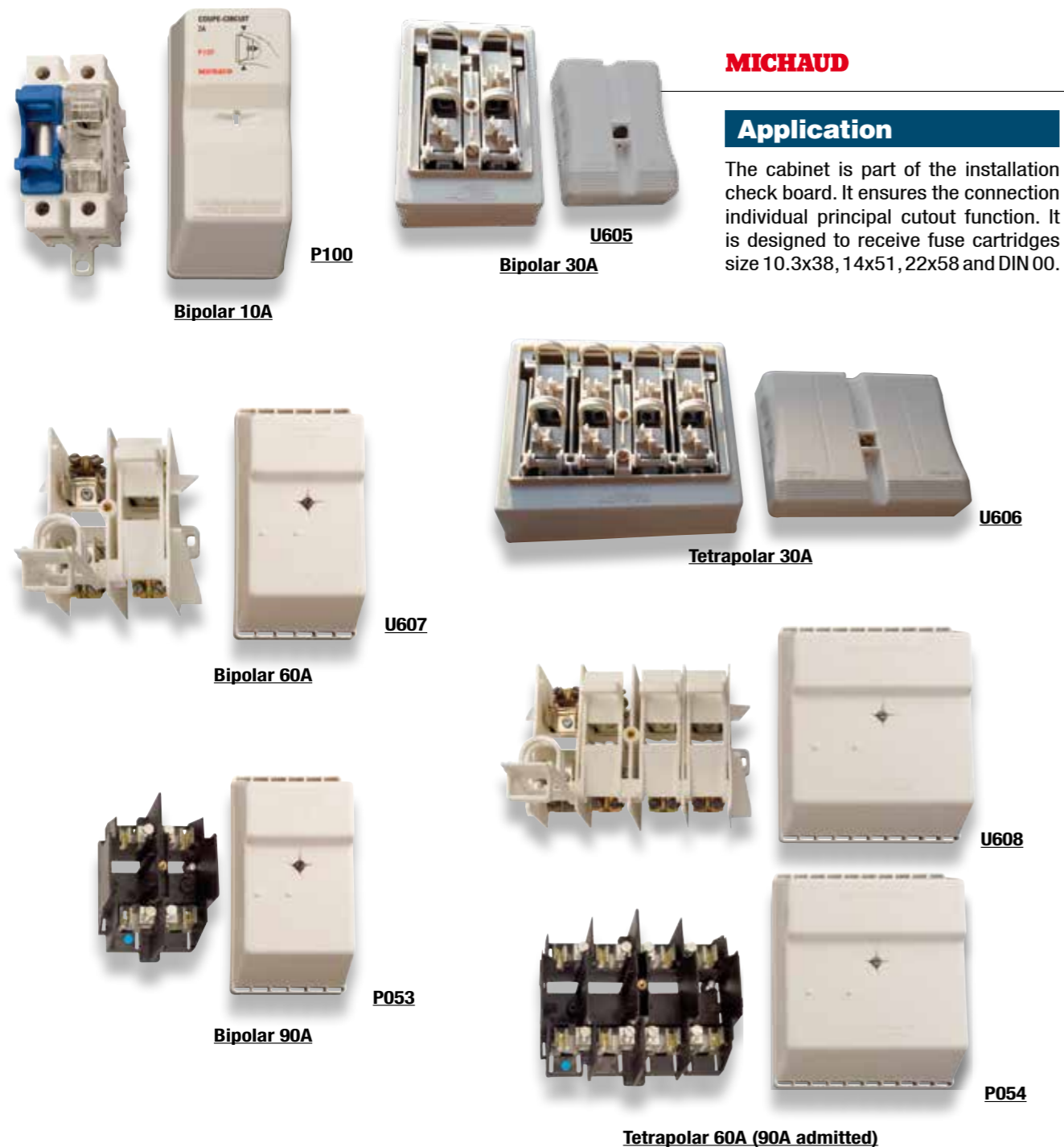

MICHAUD

Application

The cabinet is part of the installation check board. It ensures the connection individual principal cutout function. It is designed to receive fuse cartridges size 10.3x38, 14x51, 22x58 and DIN 00.

Description

- The cover is equipped with ventilations and a huge air volume restricting warming.
- The sealing is performed with two 90° notches in the cover and a hole in the tightening screw indexed in the crack for U607, U608, P053, P054, U605 and U606.
- Terminal screws are in stainless steel. They allow an important durability in harsh atmosphere.
- Fuses extraction is performed thanks to a standard handling removable handle.
- Cabinet's cage terminals of the board P100 can receive cable sections from 1.5mm² up to 10mm².
- Cutout terminals, size 14x51, can receive cable sections from 6mm² up to 25mm².
- Cutout terminals, size 22x58 and DIN 00, can receive copper or aluminium cable sections from 6mm² up to 35mm².
- The cabinet P100 is delivered equipped with a neutral tube. The other ones are delivered empty.

The synthetic materials that are used meet the criteria of the **HN 60-E-02** and **HN 60-S-02** specification.

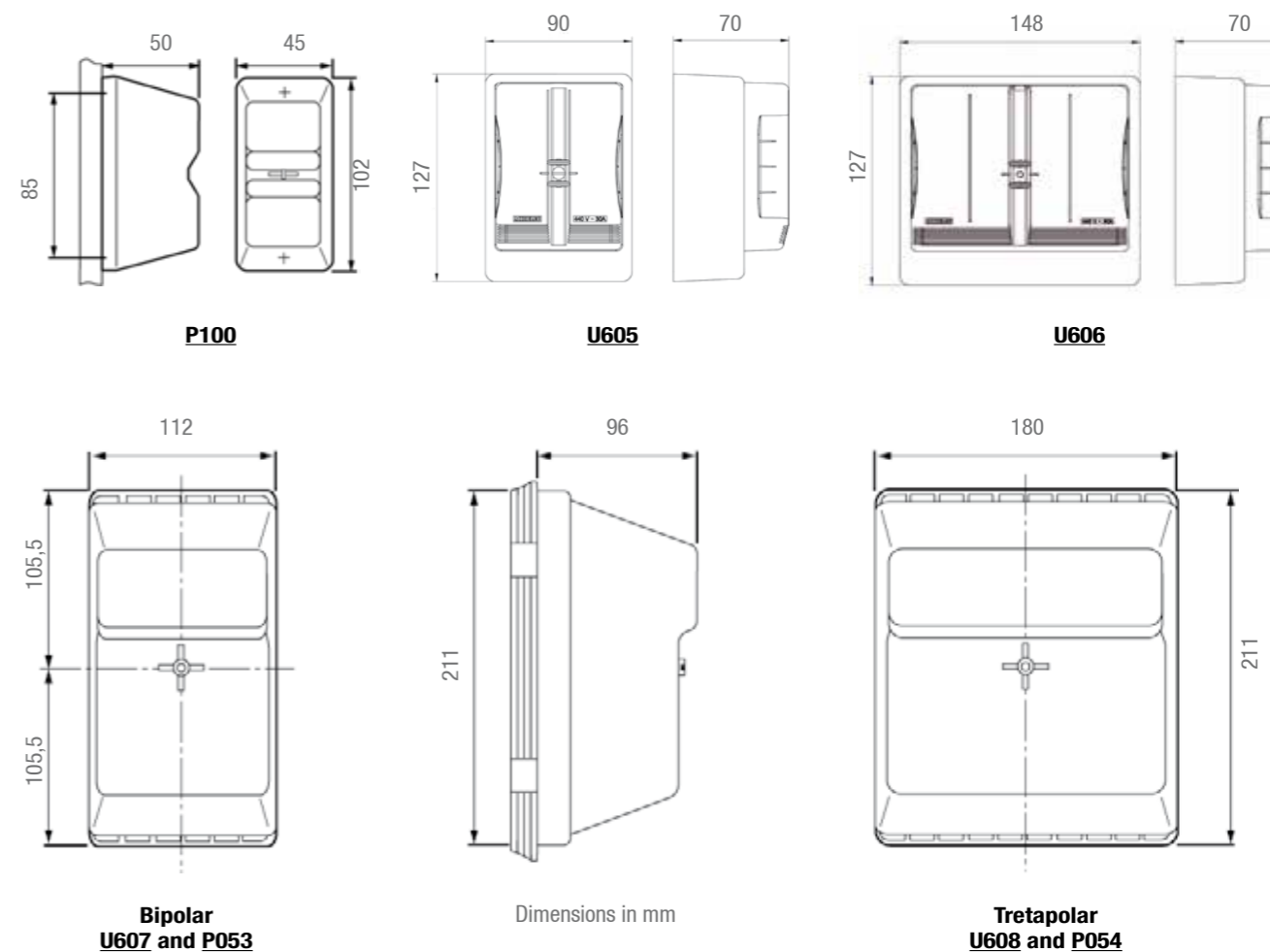

Code	Designation	Weight (kg)	Sales unit
SIZE 10.3x38			
P100	CUTOUT CABINET 2A NEUTRAL TUBE	0.170	1
SIZE 14x51			
U605	CUTOUT CABINET 30A BIPOLAR	0.230	1
U606	CUTOUT CABINET 30A TETRAPOLAR	0.350	1
SIZE 22x58			
U607	CUTOUT CABINET 60A BIPOLAR	0.510	30
U608	CUTOUT CABINET 60A TETRAPOLAR	0.780	18
SIZE 00			
P053	CUTOUT CABINET BIPOLAR 90A	0.600	1
P054	CUTOUT CABINET TETRAPOLAR 60A	0.944	1

Devices are delivered without fuse cartridges.

Option:

Fuses 10.3x38, 14x51, 22x58 and size 00 are available.

SEE SHEET
PROTECTION / Fuses



Seal

Numbered seal with wire



MICHAUD

Application

This seal is designed with a rotary closing system to wound manually. It is ideal for sealing electrical equipment, water meters, gas meters, etc. The breakage of this element highlights possible fraud.

Description

- It comprises two parts in which the wire is wound manually using a wing nut.
- Unique clockwise rotation way is to be considered.
- It is implemented manually without using particular tools.
- Wire features:
 - Stainless steel type,
 - Section approximately 0.35mm² (diameter ≈ 0.65mm),
 - Tensile strength > 30daN at ambient temperature,
 - Pre-mounted on the seal,
 - The length can be defined on request.
- The rotation mechanism is available in several colours.
- Materials resistant to UV, bad weather and various temperatures.
- The cable is delivered assembled (or separately on request).

Possible customization

- The seal flag can include standard marking:
- xxx_xxx (customer marking)
 - 1234567 (7 digits consecutive numbering).

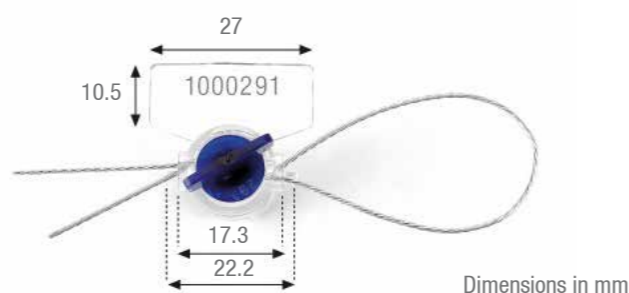

Dimensions in mm

Code	Designation	Length (mm)	Weight (kg)	Sales unit
F009	NUMBERED SEAL WITH WIRE (100 pieces)	300	0.420	1

Note:

- Preparation and packaging on request.
 - Available colours: red, blue, yellow.
 - Available cable lengths: 200mm and 400mm.
- Please enquire for any other length.

Plastic seal

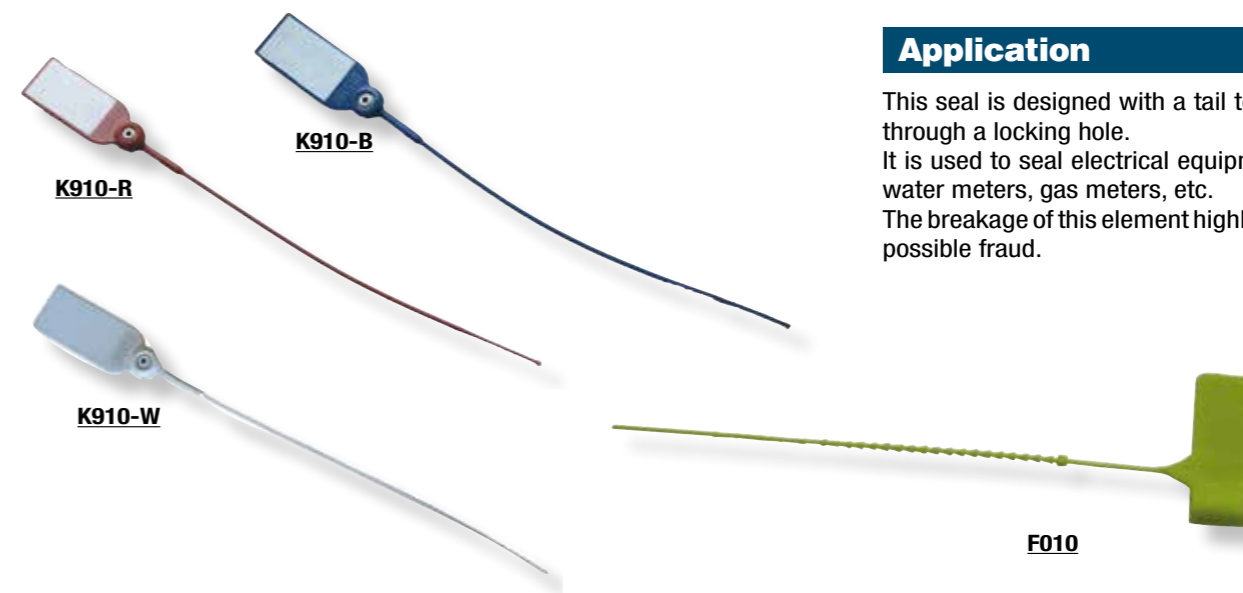

MICHAUD

Application

This seal is designed with a tail to run through a locking hole. It is used to seal electrical equipment, water meters, gas meters, etc. The breakage of this element highlights possible fraud.

Description

- These seals are made of UV resistant synthetic materials.
- The seal identification is made through:
 - A 1234567 marking type (7 digits consecutive numbering) for F010
 - A permanent marker inscription for K910
- They are implemented manually without using particular tools.

Code	Designation	Length (mm)	Weight (kg)	Sales unit
K910-B	BLUE SEAL (BOX OF 100 PIECES)	130	0.240	1
K910-R	RED SEAL (BOX OF 100 PIECES)	130	0.240	1
K910-W	WHITE SEAL (BOX OF 100 PIECES)	130	0.240	1
F010	PLASTIC SEAL WITH UNIQUE NUMBER (100 PIECES)	115	0.100	1

Sealable screw cover



MICHAUD

Application

When installing the meter, the anti-fraud system may need to be modified. This sealable screw cover is designed to seal a screw.

Code	Designation	Weight (kg)	Sales unit
P641	SEALABLE SCREW COVER (2mm diameter)	0.002	100
P642	SEALABLE SCREW COVER + 5x30 VBA SCREW	0.006	100

Insulation piercing end connector EBCP 6-35



MICHAUD

Application

This end connector is used for the connection of leading in cables to electrical equipment terminals (cutouts, electronic meters, ect). It is a universal solution to connect the connection cable and the meter terminals no matter what is the metal or the block nature. It can be fitted on copper or aluminum stranded or solid core conductors.

Description

- The end connector uses the insulation piercing technology (6-35mm²).
- The protection degree is IP2X when it is implemented.
- The maximum power running through the insulation piercing end connector is 63A for 16mm² and 90A for 25mm².
- Low dimensions enable to easily fit the end connector behind the panel in a restricted space.
- Solid teeth ensure connection in extreme environments even under low temperatures.
- The robust material constituting the cover enables it to be held with a pair of pliers during the installation, facilitating the holding.

This end connector meets the criteria of the **H-M24-2011-02598-FR** specification.

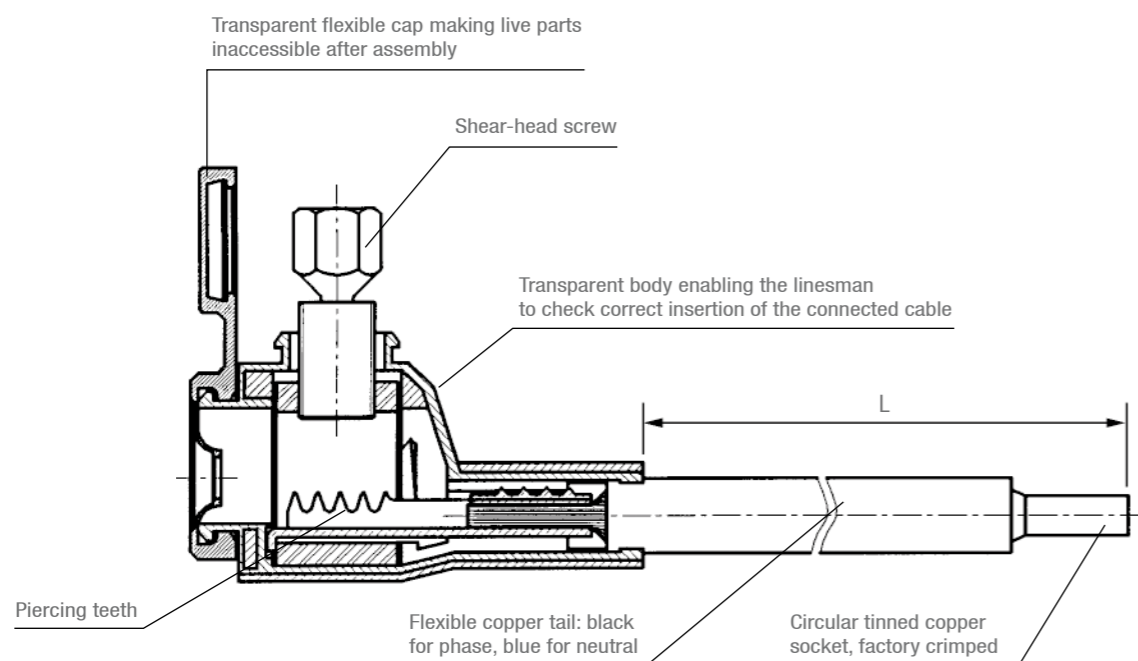

Code	Designation	Out of box length: L (mm)	Capacities (mm ²)	Weight (kg)	Sales unit
P446	EBCP 6-35/16 BLACK L235	235	6-35	0.090	10
P447	EBCP 6-35/16 BLUE L235	235		0.090	10
P648	SET OF 2 EBCP 6-35/16 (1 BLACK + 1 BLUE) L235	235		0.190	1
P651	SET OF 4 EBCP 6-35/16 (3 BLACK + 1 BLUE) L235	235		0.370	1
P222	EBCP 6-35/16 BLACK L500	500	6-35	0.140	1
P223	EBCP 6-35/16 BLUE L500	500		0.140	1
P448	EBCP 10-35/25 BLACK L190	185	10-35	0.100	10
P449	EBCP 10-35/25 BLUE L190	185		0.100	10
P649	SET OF 2 EBCP 10-35/25 (1 BLACK + 1 BLUE) L190	185		0.210	1
P650	SET OF 4 EBCP 10-35/25 (3 BLACK + 1 BLUE) L190	185		0.420	1

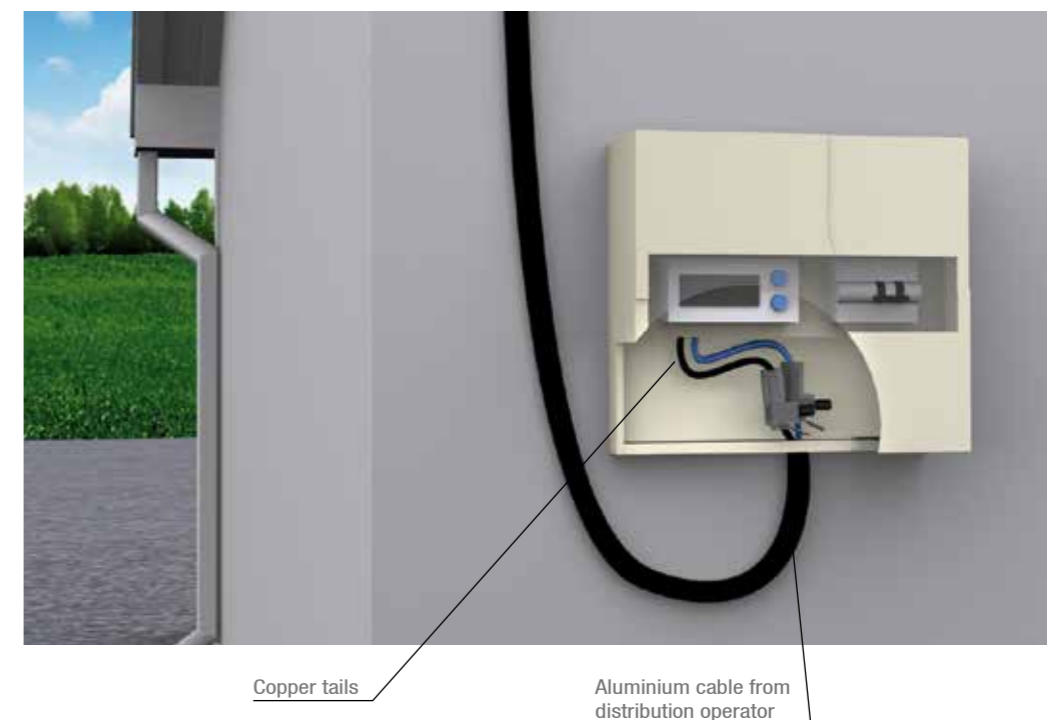

Insulation piercing end connector EBCP 16-50 Class II

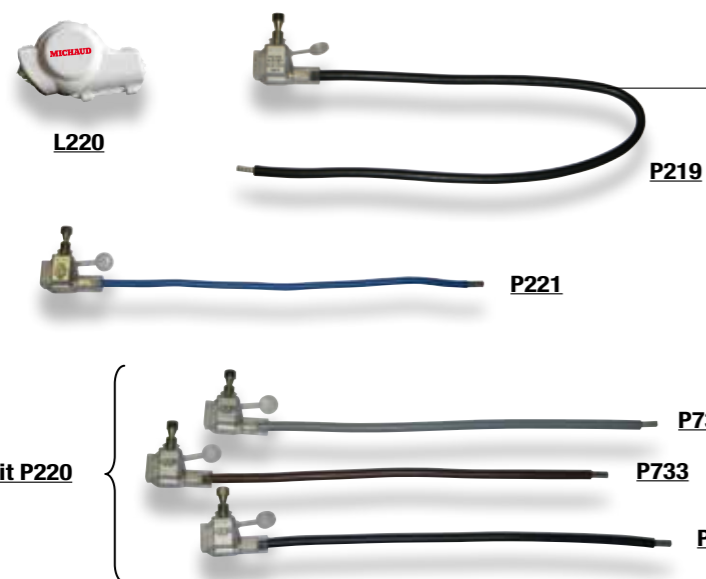

MICHAUD

Application

This end connectors range is used for the connection of leading in cables to electrical equipment terminals (cutouts, electronic meters, ect). It is a universal solution to connect the connection cable and the meter terminals no matter what is the metal or the block nature. The end connector can be fitted on sectoral or circular-shaped copper or aluminum stranded or solid core conductors. It provides class II protection using the double insulated colored tail, when equipped with the cover.

Description

- The end connector uses the insulation piercing technology (16-50mm²).
- The protection degree is IP2X when it is implemented.
- The maximum power running through the insulation piercing end connector is 80A.
- Low dimensions enable to easily fit the end connector behind the panel in a restricted space.
- Solid teeth ensure connection in extreme environments even under low temperatures.
- The robust material constituting the cover enables it to be held with a pair of pliers during installation, facilitating holding.
- The synthetic cover ensures a protection class II of the connector body and can be sealed.
- The reference P220 comprises a kit of 3 colored end connectors with black, brown or grey tail.

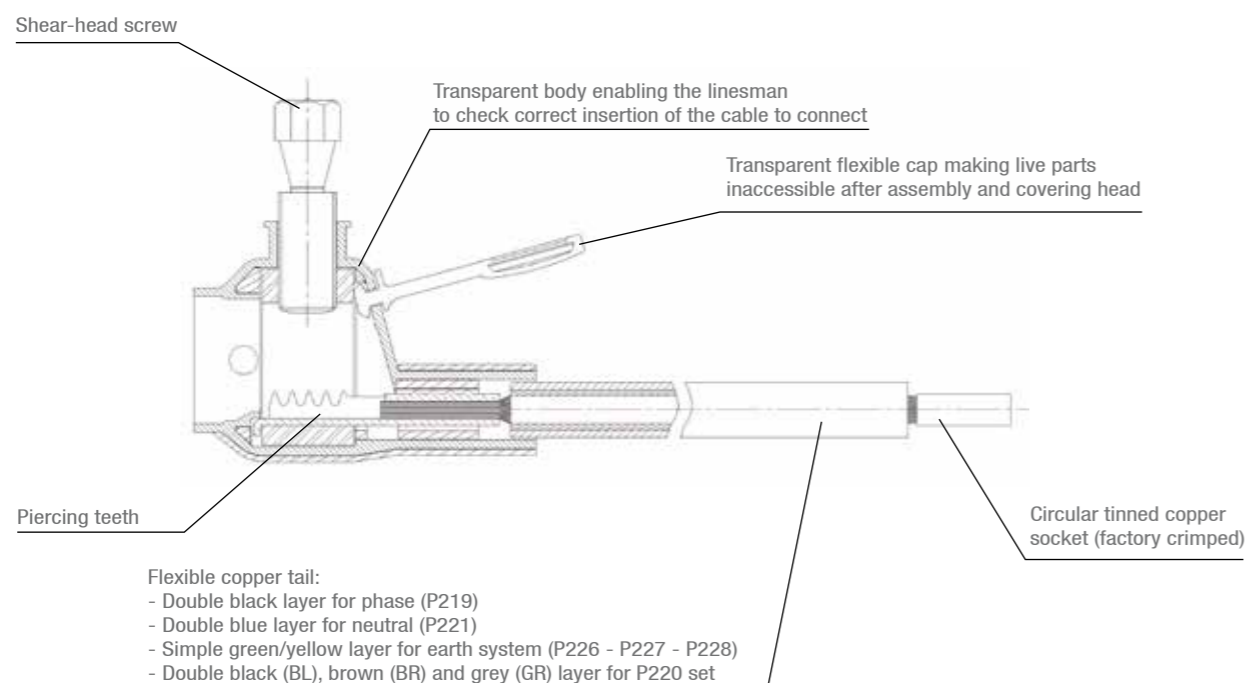

Option: Class II Setting-up

The cover (L220) enables to establish a class II installation.



Code	Designation	Out of box length: L (mm)	Capacities (mm ²)	Weight (kg)	Sales unit
P219	EBCP 50 SECT-16 BLACK L700 CLASS II	700	16-50	0.190	9
P220	SET OF 3 EBCP 50 SECT-16 BL/BR/GR L375	375		0.390	1
P221	EBCP 50 SECT-16 BLUE L375 CLASS II	375		0.130	9
P731	EBCP 50 SECT-16 BLACK L375 CLASS II	375		0.390	100
P732	EBCP 50 SECT-16 GREY L375 CLASS II	375		0.390	100
P733	EBCP 50 SECT-16 BROWN L375 CLASS II	375		0.390	100
L220	EBCPAU COVER CLASS II			0.020	12

Option:

Insulation piercing end connector for earth systems.

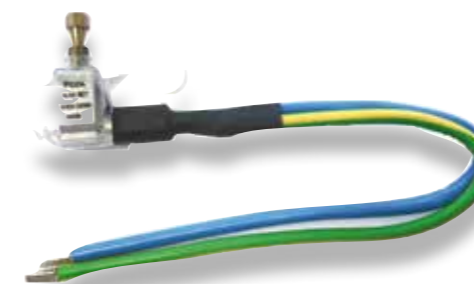

A wide range of insulation piercing end connectors has been designed for earth system:

- P 227 and P 226 with two tails (yellow/green and blue) for connecting and earth system the neutral at the same time,
 - P228 with one tail (yellow/green) for the earth conductor.
- The neutral conductor (blue) has double insulation whereas the earth conductor (yellow/green) has single insulation as it is not considered as a live element (class II not required).

Code	Designation	Out of box length: L (mm) tail	Out of box length: L (mm) earth system	Capacities (mm ²)	Weight (kg)	Sales unit
P226	EBCP P221 + YELLOW/GREEN EARTH SYSTEM L345	375	345	16-50	0.220	9
P227	EBCP P221 + YELLOW/GREEN EARTH SYSTEM L800	375	800		0.330	9
P228	EBCP 50 SECT-16 YELLOW/GREEN L800		800		0.200	9

Reversible stripping end connector EBCD 6-35

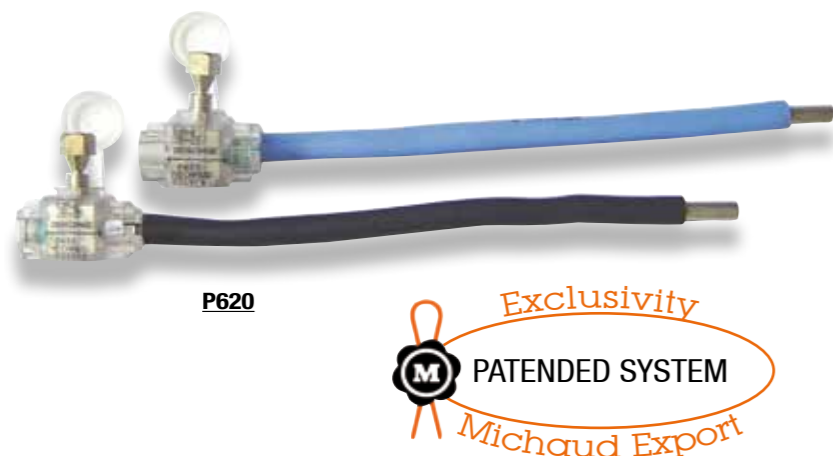

MICHAUD

Application

This end connectors range is used for the connection of leading in cables to electrical equipment terminals (cutouts, electronic meters, ect). It is a universal solution to connect the connection cable and the meter terminals no matter what is the metal or the block nature. They can be fitted on copper or aluminum stranded or solid core conductors.

Description

- The end connector uses the stripping technology (6-35mm²).
- The protection degree is IP2X when it is implemented.
- The maximum power running through the stripping end connector is 90A.
- The end connector can be connected in two opposite directions, which overcomes bulky loops in the event of insertion of the power cable from the top.
- Low dimensions enable to easily fit the end connector behind the panel in a restricted space.
- Solid teeth ensure connection in extreme environments even under low temperatures.
- The robust material constituting the cover enables it to be held with a pair of pliers during the installation facilitating the holding.

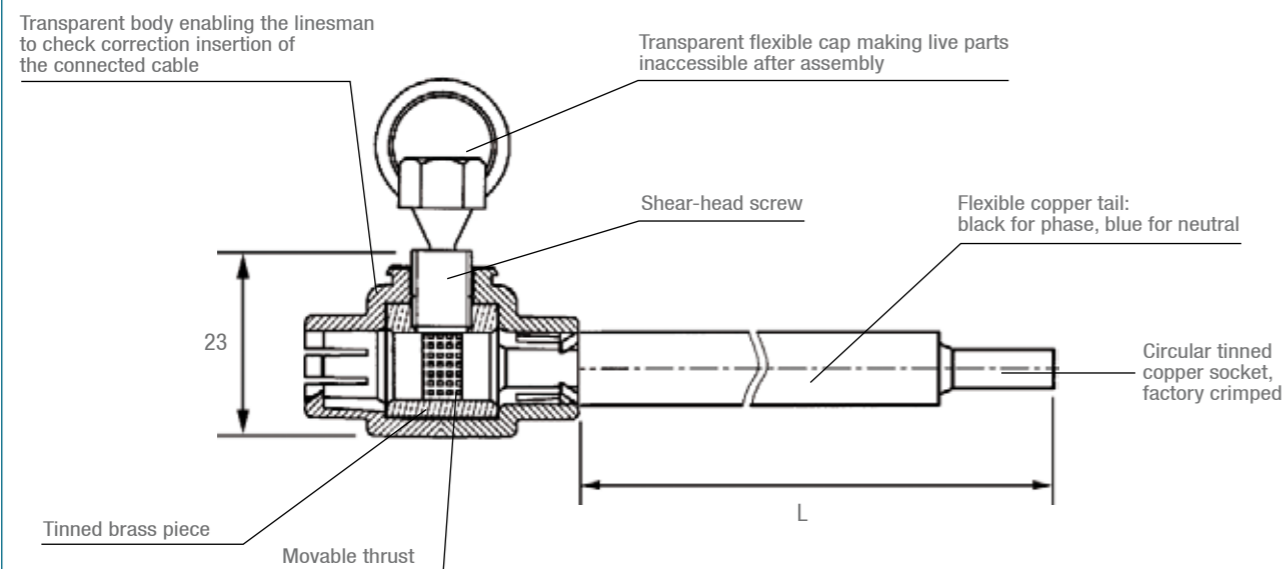

The benefits:

- + Connection possible from the top or bottom
- + A flexible cap enables to make the tightening screw inaccessible
- + The reversible end connector can either remain floating or be fixed using a 4mm diameter screw

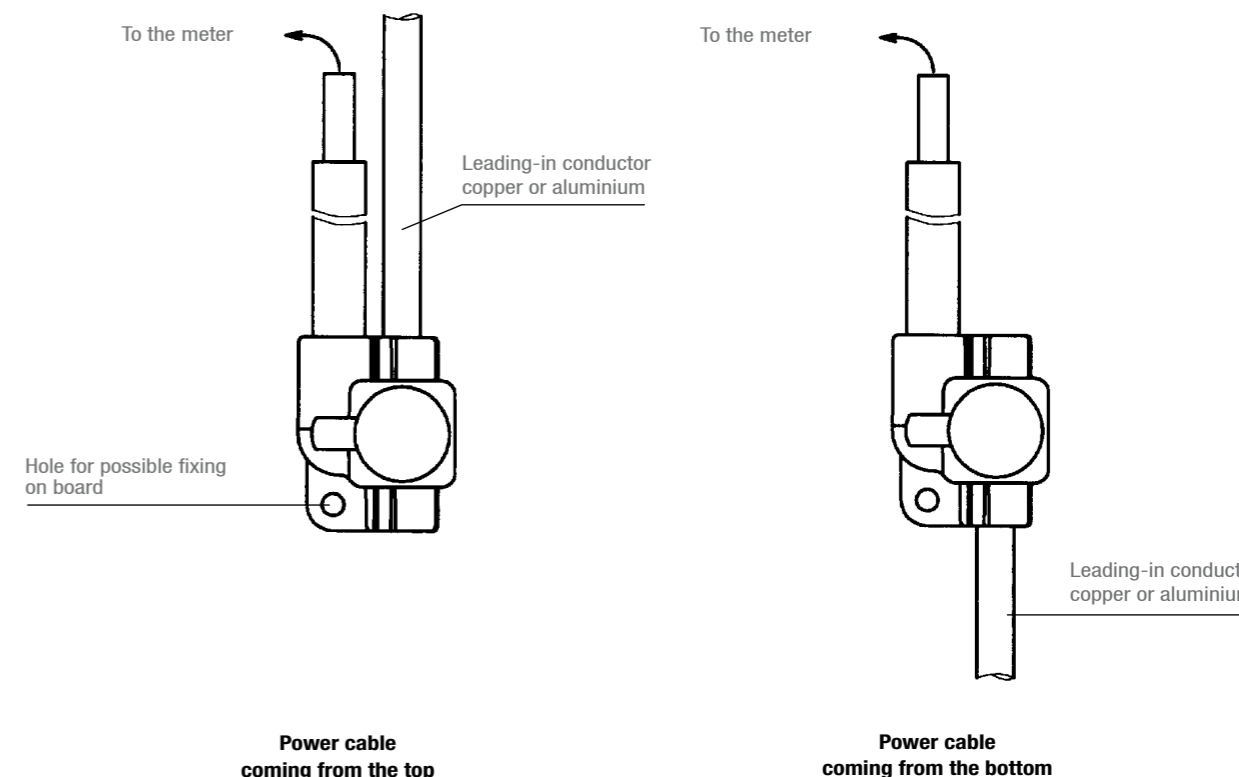

Code	Designation	Out of box length: L (mm)	Capacities (mm ²)	Weight (kg)	Sales unit
P620	SET OF 2 EBCD 35-25 (1 BLACK + 1 BLUE)	185	6-35	0.220	1
P621	SET OF 4 EBCD 35-25 (3 BLACK + 1 BLUE)			0.440	1

Nota: please enquire for any other length.

Housing

Housing

Flexible linking cable



J045

J046

MICHAUD

Application

The flexible linking cable is used for the equipment wiring when the rigid stranded core or solid core conductor installation is too difficult.

Description

- The linking cable is a 16mm² or 25mm² flexible copper conductor, multi-stranded of H07 VK type.
- Each end is factory crimped with a tinned copper-bonded socket or a stripped and tinned socket for J412 and J413. The socket is designed for connection to a plate or tunnel terminal, or to an insulation piercing terminal.

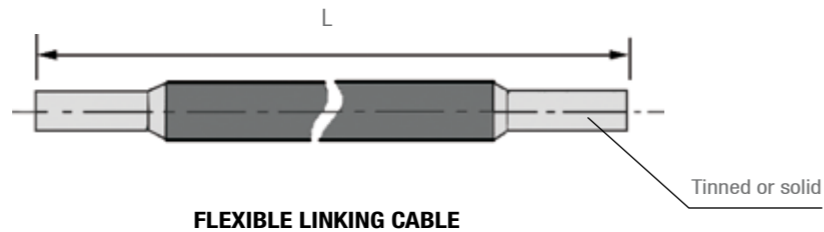

- The length L of the link is stated on the right-hand page.

Code	Designation	Conducteur (mm)	Length (mm)	Weight (kg)	Sales unit
J045	1 BLUE 16mm ² LINKING CABLE L560	16	560	0.100	10
J046	1 BLACK 16mm ² LINKING CABLE L530	16	530	0.090	10
J047	1 BLUE 16mm ² LINKING CABLE L700	16	700	0.135	10
J048	1 BLACK 16mm ² LINKING CABLE L700	16	700	0.135	10
J041	1 BLUE 16mm ² LINKING CABLE L1200	16	1 200	0.200	10
J042	1 BLACK 16mm ² LINKING CABLE L1200	16	1 200	0.210	10
J808	SET OF 2 16mm ² LINKING CABLES (1 BLUE + 1 BLACK)	16	560+530	0.215	1
J809	SET OF 4 16mm ² LINKING CABLES (1 BLUE + 3 BLACK)	16	560+3x440	0.370	1
J412	BLUE CABLE 16VK L500	16	500	0.085	200
J413	BLUE CABLE 16VK L500	16	500	0.085	200
J132	1 BLUE 25mm ² LINKING CABLE L700	25	700	0.185	5
J133	1 BLACK 25mm ² LINKING CABLE L700	25	700	0.180	5

Variants:

Two insulation piercing end connectors can be connected to the ends of the flexible linking cable for connection to other conductors.

Possible sections for conductors to be connected:

- Aluminium solid core conductors: 16M, 25M, 35M, 50M *
- Aluminium or copper rigid stranded core conductors: 10mm², 16mm², 25mm²,
- Copper multi-stranded conductors: 10mm², 16mm², 25mm² (in this case, the connection must be carried out only if the end of the conductor has been compressed).

* M means that the conductor is solid.

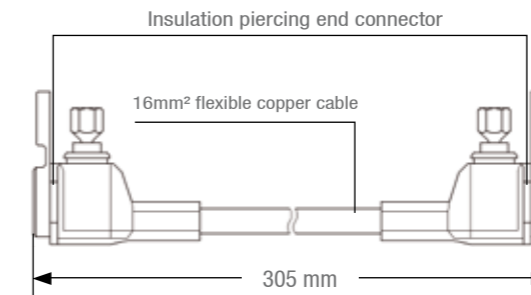

Code	Designation	Weight (kg)	Sales unit
P660	SET OF 2 16mm ² EBCPAU LINKING CABLE SINGLE 2 PIERCINGS	0.260	1
P662	SET OF 4 16mm ² EBCPAU LINKING CABLE THREE-PHASE 2 PIERCINGS	0.505	1

Reducing end connector

Service



MICHAUD

Application

This end connector is used for connecting a conductor with a given section into a terminal with a smaller one. It is usually used for industrial supplies and long-line supplies.

Description

- The dielectric strength in water is greater than 6kV.
- The flexible copper tails enable direct connection to the equipment.
- The conductor connection terminal is of insulation stripping type.
- This end connector can be used on aluminium or copper conductors.

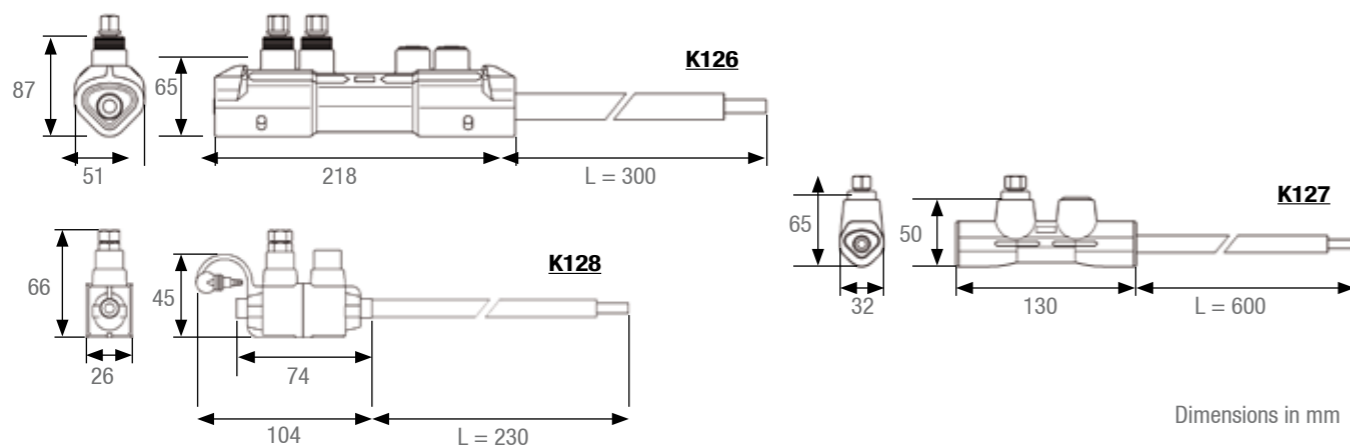

Dimensions in mm

Code	Designation	Tail length (mm)	Leading-in capacities Al-Cu (mm²)	Tail section (mm²)	Weight (kg)	Sales unit
K126	STRIPPING REDUCING END CONNECTOR 95-240	300	Round 95-150 Sectoral 95-240	50	0.780	4
K127	STRIPPING REDUCING END CONNECTOR 25-95	600	Round 25-95 Sectoral 50-95	25	0.330	2
K128	STRIPPING REDUCING END CONNECTOR 6-50M	230	Round 6-35 Round 16M-50M	25	0.170	2

Note: For other adaptations, please contact us.

Fraud-preventing service connection



MICHAUD

Application

This end connector is used for connecting a service conductor to an equipment terminal. Four models are available with black tail for Phase connection (K129 and K131) or blue for Neutral connection (K130 and K132). This solution is used to secure the outdoor connection to equipment terminals.

Description

- The dielectric strength of the end connector in water is greater than 6kV.
 - The service end connector is designed for connection to 6-35mm² section copper or aluminium conductors.
 - A 16mm² insulated flexible copper tail enables connection to equipment terminals (meter circuit-breaker).
 - The conductor connection terminal is of insulation piercing type. The shear head ensures tightening efficiency.
- Note: to prevent dismantling of the end connector with risk of fraud, none of the permanent screw heads is accessible.

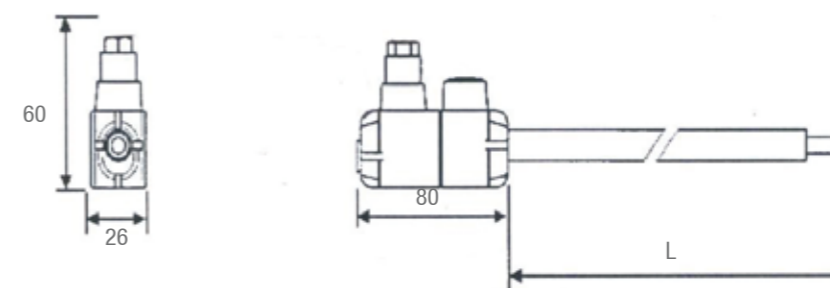

*Dimensions in mm
L= 220 (K131 and K132)
L= 520 (K129 and K130)

Code	Designation	Tail length (mm)	Leading-in capacities Al-Cu (mm²)	Tail section (mm²)	Weight (kg)	Sales unit
K131	PIERCING REDUCING END CONNECTOR 6-50M PHASE L300	220	6-35 16-50M	16	0.150	16
K132	PIERCING REDUCING END CONNECTOR 6-50M NEUTRAL L300	220	6-35 16-50M	16	0.150	16
K129	PIERCING REDUCING END CONNECTOR 6-50M PHASE L600	520	6-35 16-50M	16	0.190	12
K130	PIERCING REDUCING END CONNECTOR 6-50M NEUTRAL L600	520	6-35 16-50M	16	0.190	12



Installation

Installation

Personal protective equipment.....	p.216
Collective protective equipment.....	p.226
LV line unwinding and pulling.....	p.228
Overhead pulling grip and swivel.....	p.230
LV insulated toolings.....	p.232
Hydraulic crimping tool.....	p.238



In order to offer global service to customers, MICHAUD proposes a range of equipment and tools to facilitate and to secure products installation.



In the low voltage field, **fitters' safety and protection** are essential themes. With a range of personal protective equipment, MICHAUD ensures an installation on safe environments.



To realise an installation in the best conditions, MICHAUD offers a **range of tools and equipment** to support low voltage lines and accessories.



In order to support the fitter the best way, MICHAUD supplies its products with **didactic solutions** assuring the right installation and to guarantee fitters' safety.

Protection against the electrical risk

During the installation of electrical equipment, the protection of the fitters from risks of direct or indirect contacts is a necessity. The risk is real when a part of the human body is in contact with an active part of the installation.

Several conditions must be respected to guarantee protection:

- Installation of products with **no load**, except for specific indications
- Respect of the current **regulation**
- **Trained** and skilled **staff**
- Use of **personal protective equipment**

Classification of maximum used voltages of insulated gloves:



Class	Working voltage (V)	Tested voltage (V)
00	500	2 500
0	1 000	5 000
1	7 500	10 000
2	17 000	20 000
3	26 500	30 000
4	36 000	40 000

A support for your installations

MICHAUD uses its expertise to guide at best the fitters.

➤ Installation instructions

+ Products supplied with detailed instructions for the assembly >>>

➤ Installation videos

+ Supporting videos for some products >>>



See videos on Michaud Export Youtube Channel

➤ Training

+ Fitters' guidance on the field >>>

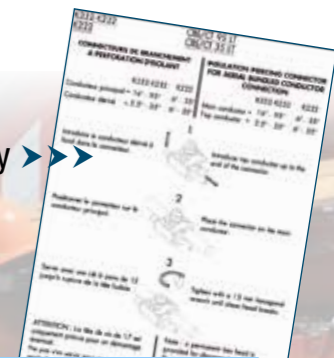

Personal protective equipment

Application

These equipment aim to protect hands during installation works.

Hands protection

PROTECTIVE NITRILE GLOVES



U833-1

These gloves are in nitrile on hands palm. They offer an important perforation resistance.

PROTECTIVE LEATHER GLOVES



U833-2

These leather gloves are made of red leather. They offer an important perforation and cutting up resistance.

HANDLING LEATHER GLOVES



F081

The handling leather gloves protect insulating gloves against sharp and cutting objects. A scratch band holds the handling gloves around the wrists.

Code	Designation	Size	Weight (kg)	Sales unit
U833-1	PROTECTIVE NITRILE GLOVES	S - M - L - XL	0.200	1
U833-2	PROTECTIVE LEATHER GLOVES	33cm	0.220	1
F081	HANDLING LEATHER GLOVES	10	0.160	1

Insulating gloves



U82x

Application

These insulating gloves are designed to protect against electrical shocks during powered works. According to the work nature to perform, the gloves range goes from class 00 to class 4. Available in unique size only (10 size).

Class	Nominal network alternative voltage (V)	Tested voltage (V)
00	500	2 500
0	1 000	5 000
1	7 500	10 000
2	17 000	20 000
3	26 500	30 000
4	36 000	40 000

Code	Designation	Weight (kg)	Sales unit
U820-10	INSULATING GLOVES CLASS 00 (500V)	0.530	1
U821-10	INSULATING GLOVES CLASS 0 (1 000V)	0.550	1
U822-10	INSULATING GLOVES CLASS 1 (7 500V)	0.575	1
U823-10	INSULATING GLOVES CLASS 2 (17 000V)	0.600	1
U824-10	INSULATING GLOVES CLASS 3 (26 500V)	0.650	1
U825-10	INSULATING GLOVES CLASS 4 (36 000V)	0.700	1

Personal protective equipment

Application

These equipment aim to protect the head and the face during installation works.

Head protection



U830-1



U830-2



U830-4



U830-3

Breathing protection



U832-1

The half mask without valve is FFP1.
It offers 75% of dust absorption.



U832-2

The half mask with valve is FFP2.
It offers 95% of dust absorption.

Code	Designation	Weight (kg)	Sales unit
U830-1	BASIC HELMET	0.300	1
U830-2	HELMET WITH TOOTH WHEEL	0.300	1
U830-3	CHIN STRAP WITHOUT CHIN REST	0.050	1
U830-4	CHIN STRAP WITH CHIN REST	0.030	1
U832-1	FILTERING HALF MASK WITHOUT VALVE - FFP1	0.040	1
U832-2	FILTERING HALF MASK WITH VALVE - FFP2	0.070	1

Eyes protection



U831-1



U831-2

These tinted protection glasses have a UV filter.



U831-3



U831-4

The flexible vinyl frame gets an anti-fog treatment.



U831-5



U831-6

This face shield guarantees an electric arc protection.

Code	Designation	Weight (kg)	Sales unit
U831-1	PROTECTION GLASSES	0.030	1
U831-2	PROTECTION GLASSES TINTED - UV FILTER	0.030	1
U831-3	PROTECTION OVER GLASSES	0.035	1
U831-4	PROTECTION MASK	0.070	1
U831-5	FACE SHIELD - IMPACT PROTECTION	0.300	1
U831-6	FACE SHIELD - ELECTRIC ARC PROTECTION	0.500	1

Personal protective equipment

Dielectric and mechanical protection



U826 - high shoes



U827 - short shoes

Application

These safety shoes ensure protection against electrical shocks. They also offer a mechanical protection. Two models are available :

- high shoes
- short shoes

Description

- These shoes are made of bovine black leather. They comprise a polyamide anti-allergic lining, a polyurethane antistatic sole and a non-metallic end. The antistatic property of the sole does not protect against electrical shocks.
 - The models are tested in compliance with ANSI Z41 and ASTM F2413-05 standards. When 14 000 and 18 000V currents are applied during 1 minute with a 60Hz frequency, the passage of current intensity is inferior to 1mA (according to conditions described in the standards).
 - Available sizes go from 39 up to 46.
 - The shoes offer an impact resistance of 200J and a compression resistance of 15kN. The sole is resistant to hydrocarbons.
 - The resistance to perforation is about 1100N.
 - The energy absorption in the heel is superior to 20J for both models.
 - Shoes are waterproof.
 - They provide an insulation against cold and heat coming from the ground. The resistance to heat contact from the ground is 300°C.
 - The soles are nonskid.
 - Dielectric safety shoes are not a substitute to obligatory PPE but an element of secondary protection.
- These shoes meet the criteria of **EN ISO 20345** standard.

Code	Designation	Available sizes	Protection classes	Weight (kg)	Sales unit
U826	HIGH SAFETY SHOES - DIELECTRIC AND MECHANICAL PROTECTION	39 up to 46	SB+P+E+CI+HI+WRU+HRO+SRC+FO	0.900	1
U827	SHORT SAFETY SHOES - DIELECTRIC AND MECHANICAL PROTECTION	39 up to 46	SB+P+E+CI+HI+WRU+HRO+SRC+FO	0.700	1

Required size :

Add the required size to the reference.

Example with the high shoes model, size 42 : **U826-42**

Mechanical protection



U828 - high shoes



U829 - short shoes

Application

These safety shoes ensure a mechanical protection. Two models are available :

- high shoes
- short shoes

Description

- These shoes are made of bovine black leather. They comprise a polyamide anti-allergic lining, a polyurethane antistatic sole and a non-metallic end. The antistatic property of the sole does not protect against electrical shocks.
- Available sizes go from 39 up to 46.
- The shoes offer an impact resistance of 200J and a compression resistance of 15kN.
- They disperse electrostatic charges.
- The energy absorption in the heel is superior to 20J for the short shoes and 25J for the high ones.
- Shoes are waterproof.
- They provide an insulation against cold coming from the ground. The high shoes also provide a resistance to heat contact from the ground of 300°C (U828).
- The soles are nonskid.

These shoes meet the criteria of **EN ISO 20345** standard.

Code	Designation	Available sizes	Protection classes	Weight (kg)	Sales unit
U828	HIGH SAFETY SHOES - MECHANICAL PROTECTION	39 up to 46	S2+CI+HRO+SRC	0.900	1
U829	SHORT SAFETY SHOES - MECHANICAL PROTECTION	39 up to 46	S2+CI+SRC	0.700	1

Required size :

Add the required size to the reference.

Example with the high shoes model, size 42 : **U828-42**

Personal protective equipment

Application

These equipment aim to protect the fitter from falls during installation works at height.

Fall protection

HARNESS



U834-2



U834-3



U834-4



U834-5

Option : Kit

- 1 harness
- 1 tether
- 2 carabiners
- 1 bag



U834-1



U834-6

BELT



U835-1

Option : Kit

- 1 belt
- 1 rope
- 1 carabiner



U835-2

Code	Designation	Weight (kg)	Sales unit
U834-2	HARNESS 1 ANCHORING POINT	0.750	1
U834-3	HARNESS 2 ANCHORING POINT	0.800	1
U834-4	HARNESS 4 ANCHORING POINT	0.950	1
U834-5	HARNESS 2 ANCHORING POINT - DIELECTRIC	0.900	1
U834-1	BASIC HARNESS KIT (HARNESS + TETHER + 2 CARABINERS + BAG)	1.300	1
U834-6	WAIST HARNESS	0.500	1
U835-1	WORK POSITIONNING BELT	0.300	1
U835-2	WORK POSITIONNING BELT (BELT + ROPE + CARABINER)	0.580	1

ROPE AND TETHER



U836-1 U836-2



U837-3



U837-1



U837-2



U837-4



U837-5



U837-6



U837-7

ACCESSORIES



U836-3



U836-4



U838-2



U838-3



U838-4

Code	Designation	Weight (kg)	Sales unit
U836-1	POLYAMIDE ROPE - 10 METERS	3.00	1
U836-2	POLYAMIDE ROPE - 20 METERS	6.00	1
U837-1	Y TETHER WITH CARABINERS AND ENERGY ABSORBER	0.700	1
U837-2	SIMPLE TETHER WITH CARABINERS AND ENERGY ABSORBER	0.600	1
U837-3	SIMPLE TETHER WITH CARABINERS AND ENERGY ABSORBER - DIELECTRIC	0.800	1
U837-4	Y TETHER WITH CARABINERS	1.10	1
U837-5	SIMPLE TETHER WITH CARABINERS	0.800	1
U837-6	SIMPLE TETHER	0.400	1
U837-7	SIMPLE ADJUSTABLE TETHER	0.450	1
U837-8	SIMPLE ADJUSTABLE TETHER WITH CARABINERS - DIELECTRIC	0.650	1
U836-3	GUIDED TYPE FALL ARRESTERS	0.230	1
U836-4	CARABINER	0.080	1
U838-1	TIE-OFF	0.070	1
U838-2	TIE-OFF - DIELECTRIC	0.030	1
U838-3	ANCHORING POINT	0.030	1
U838-4	HANGING RING	0.050	1

Personal protective equipment

Insulating mat



U840

Application

This mat is used to protect the fitter working area from contact voltage, during electrical work, without load in HV context and under load in LV one. Several models are available from class 0 to class 4.

Description

- This mat is made of rubber with both non-skid areas.
 - This mat offers a high dielectric strength.
 - It may be used for temperatures from -40°C to +70°C.
 - This mat is used directly laid on the ground.
 - Insulating mat is not a substitute to obligatory PPE but an element of secondary protection
- It meets the criteria of **IEC 61111** standard.

Code	Designation	Working alternative voltage (V)	Thickness (mm)	Weight (kg)	Sales unit
U840-0 1x1	INSULATING MAT CLASS 0 - 1x1m	1 000	2.5	3.98	1
U840-1 1x1	INSULATING MAT CLASS 1 - 1x1m	7 500	3	4.74	1
U840-2 1x1	INSULATING MAT CLASS 2 - 1x1m	17 000	3.5	5.51	1
U840-3 1x1	INSULATING MAT CLASS 3 - 1x1m	26 500	4	7.19	1
U840-4 1x1	INSULATING MAT CLASS 4 - 1x1m	36 000	5	8.11	1

Insulating ladder

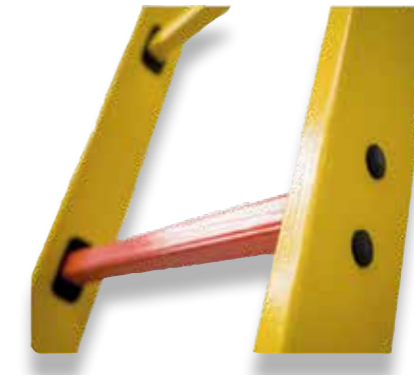

U841

Application

This insulating ladder protects the fitter from current voltage during electrical installation works.

Description

- This ladder is in fibreglass. It is entirely made of composite material and does not comprise metallic part to realise mechanical bonding (screw, bolt...).
- This ladder is light and easily transportable.
- It offers a high resistance to atmospheric and chemical agents.
- It is available in several lengths.
- The ladder bottom is equipped with a stabilizer for models with a length superior to 3 meters.

This ladder meets the criteria of **EN 131** standard.

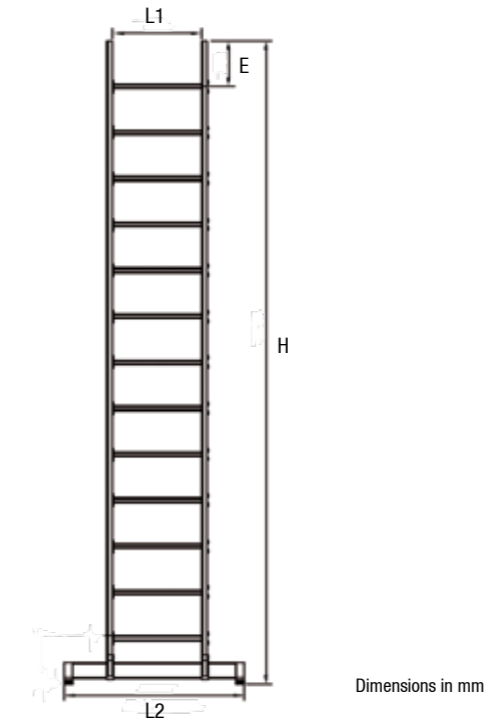

Code	Designation	Dimensions (mm)				Number of ladder rungs	Weight (kg)	Sales unit
		H	L1	L2	E			
U841-3	INSULATING LADDER 3m	3	400	400	250	11	9.5	1
U841-3.5	INSULATING LADDER 3.5m	3.5	400	800	250	13	10.5	1
U841-4	INSULATING LADDER 4m	4	400	850	250	15	12	1
U841-4.5	INSULATING LADDER 4.5m	4.5	400	900	250	17	14	1
U841-5	INSULATING LADDER 5m	5	400	950	250	19	16	1
U841-6	INSULATING LADDER 6m	6	400	1050	250	23	19	1

Collective protective equipment

Warning tape



F865

Application

This warning tape enables to secure and delimit a work area on a construction site.

Description

- The warning tape is red and white (stripes).
- It is made of polyethylene.
- It is delivered in roll of 100m.

Code	Designation	Length (m)	Width (mm)	Thickness (mm)	Weight (kg)	Sales unit
F865	WARNING TAPE RED/WHITE (ROLL 100m)	100	70	0.050	1.500	1

Safety barrier

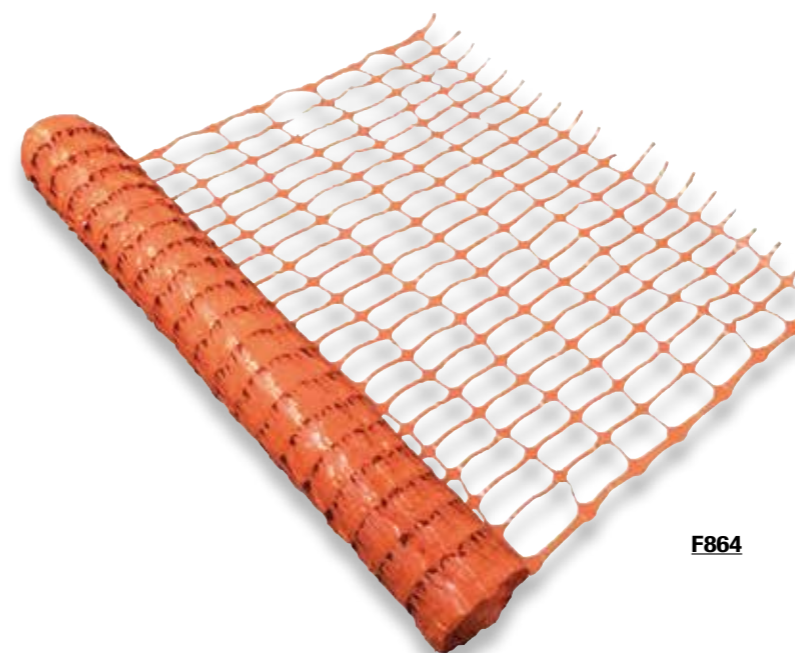

F864

Application

This safety barrier enables to secure and delimit a work area on a construction site. This netting is made of stretch mesh and offers a high tensile strength allowing extension without any risk of deformation or tearing.

Description

- The safety barrier is orange.
- The unoriented manufacturing process makes it more resistant in lengthwise axis.
- The netting is made of high density polyethylene.

It meets the criteria of the **EN 13934-1** standard.

Code	Designation	Length (m)	Height (m)	Color	Weight (g/m ²)	Sales unit
F864	NETTING BARRIER	50	1	Orange	90	1

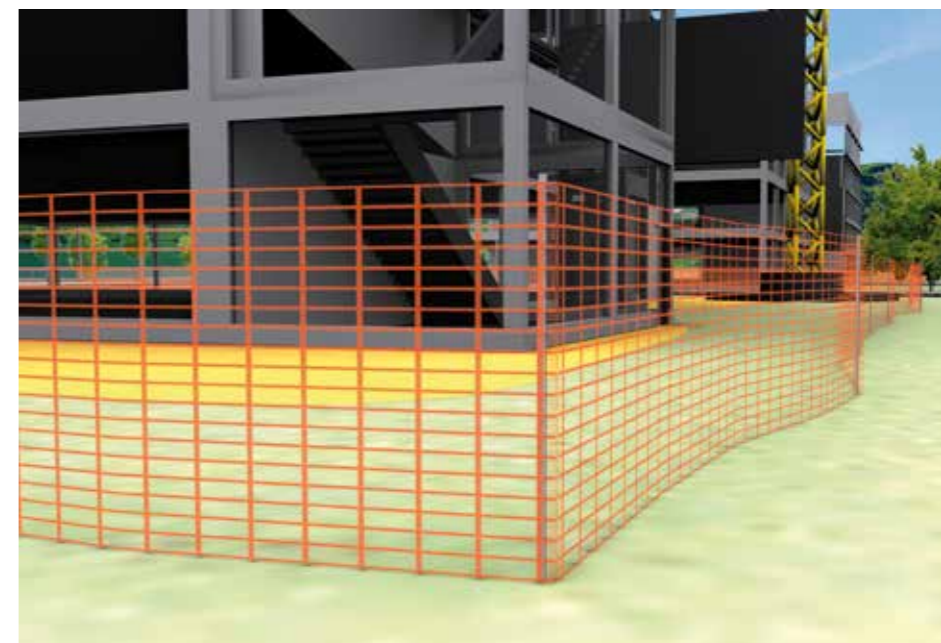

LV line unwinding and pulling

Pulley for aerial bundled conductors

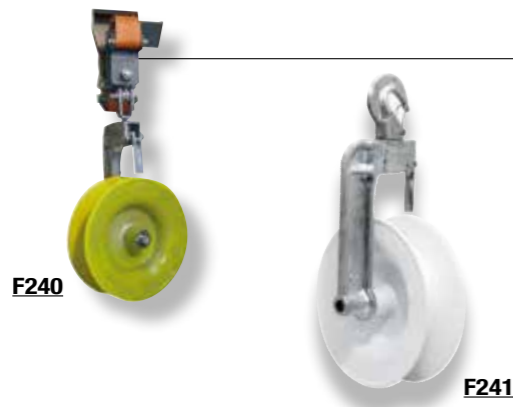

MIRELEC

Application

This pulley is designed to receive low voltage A.B.C. (Aerial Bundled Conductors) for unwinding and pulling operations.

Description

- The body of the pulley is made of aluminium alloy.
- The 250mm diameter wheel is made of synthetic materials. It has a 60mm groove to make the passage of A.B.C. up to 3x150 + 70N + 16mm² easier.
- The pulley is equipped with safety locking allowing the rope to be fitted with one hand. This system prevents the rope and therefore the A.B.C. from jumping out of the wheel during handling.
- Two types of pole fixing are available:
 - Pulley with swivelling hook,
 - Pulley with ratchet tightener and 1.20m strap.

Code	Designation	Pulley width (mm)	Operating load (daN)	Weight (kg)	Sales unit
F240	PULLEY WITH STRAP	60	800	5.200	1
F241	PULLEY WITH HOOK	60	800	2.650	1

For other characteristics, please contact us.

Mechanical winch



Application

This mechanical winch is designed to pull conductors of a low voltage power line. Light and small, it can be used for all types of cable adjustments, in particular on top of supports. It can be used also for lifting loads, stowing poles and other applications.

Description

- Two hooks at each end enable the winch to be fixed. They are equipped with a safety locking pin.
- The operating arm with ergonomic handle makes it easier to adjust the traction.
- The body is equipped with ratchet tightening system.

Code	Designation	Operating load (daN)	Weight (kg)	Sales unit
U354	MECHANICAL WINCH 500	500	9.00	1
U355	MECHANICAL WINCH 1 000	1 000	9.00	1

Overhead comealong clamp



MIRELEC

Application

This overhead comealong clamp is designed to pull, retain and stretch bare or insulated conductors of a power line. Three models are available according to the type of conductors to be implemented:

- Bare steel or aluminium cable,
- A.B.C. (Aerial Bundled Conductors) type neutral messenger,
- A.B.C. type fully supported.

Description

- The half-cylinder shaped parallel jaws ensure secure tightening of the conductor, protecting it.
- An ergonomic handle with its wide opening enables good handling.
- The sliding of the jaws and arms is facilitated thanks to bolts and slides.
- The assembly is made of corrosion-proof galvanised steel or aluminium.

Code	Designation	Conductor type	Tighten capacity	Maximum load (daN)	Weight (kg)	Sales unit
F257	BARE CONDUCTOR COMEALONG 4-12mm	Bare Al / Steel	4-12mm	1 700	0.500	1
F258	INSULATED CONDUCTOR COMEALONG 6-14mm	Insulated Al / Cu	6-14mm	800	1.555	1
F269	SELF-SUPPORTED A.B.C. COMEALONG 4x95-150mm ²	A.B.C.	4x95mm ²	600	6.500	1
			4x150mm ²	900		

Wire-strainer



Application

This wire-strainer is designed to pull conductors on a low voltage electrical line manually.

Code	Designation	SWL (kg)	Ø cable or Ø wire to pull (mm)	Lever's two way distance (mm)	Comealong type	Weight (kg)	Sales unit
U353	WIRE-STRAINER (400KG)	400	from 5 up to 8	65	2	4.90	1
U351	WIRE-STRAINER (600KG)	600	from 7 up to 15	75	3	5.20	1
U352	WIRE-STRAINER (800KG)	800	from 14 up to 18	90	4	6.20	1

Wooden pole climbers



Application

These climbers are designed to help fitters climbing along a wooden pole and facilitate work at height. Sold in pair.

Code	Designation	Weight (kg)	Sales unit
F448 - 20	WOODEN POLE CLIMBERS 6 PEAKS DIAM 20cm	2.45	1
F448 - 25	WOODEN POLE CLIMBERS 6 PEAKS DIAM 25cm	2.70	1
F448 - 30	WOODEN POLE CLIMBERS 6 PEAKS DIAM 30cm	3.00	1
F448 - 35	WOODEN POLE CLIMBERS 6 PEAKS DIAM 35cm	3.20	1

Overhead pulling grip and swivel

Swivel



U356-14

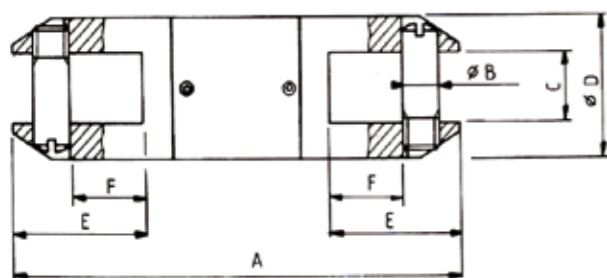

MIRELEC

Application

This overhead swivel is used between two overhead pulling grips to replace an old conductor by a new one or between a pulling grip and the wire rope on the winch. It prevents any twisting of the conductor during pulling, unreeling and laying. All of the parts are made of alloyed steel.

Code	Designation	A (mm)	B (mm)	C (mm)	Ø D (mm)	E (mm)	Linear break-down (daN)	Weight (kg)	Sales unit
U356-14	OVERHEAD SWIVEL DIAMETER 14	61	6	6	14	16	1 650	0.075	1
U356-16	OVERHEAD SWIVEL DIAMETER 16	70	6.5	8	16	19	1 700	0.100	1
U356-22	OVERHEAD SWIVEL DIAMETER 22	88	8.5	10	22	29	4 600	0.230	1
U356-34	OVERHEAD SWIVEL DIAMETER 34	122	12	16	34	35	6 500	0.520	1
U356-38	OVERHEAD SWIVEL DIAMETER 38	122	12	16	38	35	9 500	0.690	1
U356-55	OVERHEAD SWIVEL DIAMETER 55	200	16	32	55	35	5 000	2.000	1

Single and double eye grip



Single grip

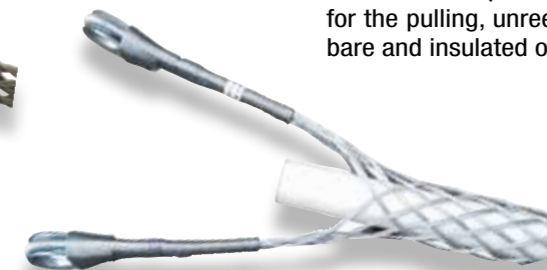

Double grip

MIRELEC

Application

This overhead pulling grip is designed for the pulling, unreeling and laying of bare and insulated overhead cables.

Description

- Eyes are made of galvanised steel.
- The single eye grip gets a grip at one of its ends and is closed at the other end (with a spliced core lug). It is used for cable-end pulling.
- The double eye grip is opened at both ends. It is used to start the pulling at the cable-end and to continue it in any part of the cable.

Code	Designation	Ø of cables (mm)	Maximum operating load (T)	M (mm)	N (mm)	Weight (kg)	Sales unit
SINGLE GRIP							
U357-8	OVERHEAD PULLING GRIP SINGLE EYE Ø 8	8 up to 10	0.400	250	125	0.070	1
U357-10	OVERHEAD PULLING GRIP SINGLE EYE Ø 10	10 up to 15	0.400	300	125	0.070	1
U357-15	OVERHEAD PULLING GRIP SINGLE EYE Ø 15	15 up to 20	0.800	350	130	0.129	1
U357-20	OVERHEAD PULLING GRIP SINGLE EYE Ø 20	18 up to 25	0.800	425	130	0.135	1
U357-25	OVERHEAD PULLING GRIP SINGLE EYE Ø 25	23 up to 30	1.650	475	135	0.225	1
U357-30	OVERHEAD PULLING GRIP SINGLE EYE Ø 30	30 up to 38	1.650	500	135	0.230	1
U357-35	OVERHEAD PULLING GRIP SINGLE EYE Ø 35	35 up to 43	3.400	525	150	0.445	1
U357-40	OVERHEAD PULLING GRIP SINGLE EYE Ø 40	40 up to 50	3.400	575	155	0.480	1
DOUBLE GRIP							
U358-8	OVERHEAD PULLING GRIP DOUBLE EYE Ø 8	8 up to 10	0.400	250	125	0.100	1
U358-10	OVERHEAD PULLING GRIP DOUBLE EYE Ø 10	10 up to 15	0.400	300	125	0.142	1
U358-15	OVERHEAD PULLING GRIP DOUBLE EYE Ø 15	15 up to 20	0.800	350	130	0.150	1
U358-20	OVERHEAD PULLING GRIP DOUBLE EYE Ø 20	18 up to 25	0.800	425	130	0.157	1
U358-25	OVERHEAD PULLING GRIP DOUBLE EYE Ø 25	23 up to 30	1.650	475	135	0.271	1
U358-30	OVERHEAD PULLING GRIP DOUBLE EYE Ø 30	30 up to 38	1.650	500	135	0.276	1
U358-35	OVERHEAD PULLING GRIP DOUBLE EYE Ø 35	35 up to 43	3.400	525	150	0.520	1
U358-40	OVERHEAD PULLING GRIP DOUBLE EYE Ø 40	40 up to 50	3.400	575	155	0.560	1

The same models are available in stainless steel or in Rilsan. Please contact us. Further models type sleeved are also available.

LV insulated tooling

Application

These toolings are designed to realise connections.



F445

INSULATED RATCHET WRENCH HEXAGONAL

This ratchet spanner is generally used for the installation of connectors. It has a H13/H17 end socket. It is manufactured according to the standard: **DIN EN 60900: 2012 = 1000V + double triangle.**



K004

HOLDING SPANNER

The holding spanner is designed to facilitate the installation of service connectors. It is placed on the connector walls.



K005

INSULATED WEDGE SEPARATOR

The wedge separator is designed to separate a conductor in an aerial bundle or in an underground cable to enable localised work on this conductor. It comprises 2 wedges linked by a 1m long cord. Each black wedge is made of strong synthetic material, and is UV, shock and cold resistant.

2 separations are possible:

- 2cm: for the installation of connectors.
- 4cm: for the installation of anchoring and pulling devices.

A hole at the end enables insertion of a tool to make 90° rotation easier, providing the separation from 2 to 4cm. Very smooth ribs and a slight penetration angle make wedge insertion in the cable easier.



F450

BRUSH

This brush is used with neutral grease to brush conductor cores in order to remove the oxide film.



L024

NEUTRAL GREASE

This tube of neutral grease is used to brush the conductors to be connected and thus protect the electrical connection. The nozzle enables grease to be applied to contacts that are difficult to access. The neutral grease complies with the ERDF France technical guide. It is neutral as regards aluminium and copper. It has the following technical characteristics:

- A high drop point (190°),
- A wide use temperature range (-20°C up to + 120°C).

Code	Designation	Weight (kg)	Sales unit
F450	BRUSH FOR CONDUCTOR WITH CASE	0.080	1
F445	INSULATED RATCHET WRENCH HEXAGONAL 13/17mm	0.380	1
K004	HOLDING SPANNER CBS/RDP	0.080	20
K005	INSULATED WEDGE SEPARATOR	0.360	5
K007	INSULATED WEDGE SEPARATOR 200x15x9mm	0.050	100
L024	CONTACTAL N190 NEUTRAL GREASE - TUBE OF 100g	0.115	1

Spanners

INSULATED CROSS SPANNER 8 - 10 - 13 - 17mm

The particular structure of this spanner allows it to be easily held. Generally, 13 and 17mm spanners are used for the installation of insulation piercing connectors. The 4 sides are insulated from one to another one.



F460

Code	Designation	Weight (kg)	Sales unit
F460	INSULATED CROSS SPANNER 8-10-13-17mm	0.400	1

MONKEY WRENCH

These monkey wrenches ensure a 1000V protection.



U814-1



U814-2

Code	Designation	Length (mm)	Weight (kg)	Sales unit
U814-1	MONKEY WRENCH 10" 1000V	250	0.620	1
U814-2	MONKEY WRENCH 12" 1000V	300	0.950	1

HEX KEYS



U814-3

This set of spherical head hex keys comprises 10 pieces covering diameters from 1.5 up to 10mm.

Code	Designation	Ø key (mm)	Weight (kg)	Sales unit
U814-3	SET OF 10 SPHERICAL HEAD HEX KEYS	1.5 2 2.5 3 4 5 5.5 6 8 10	0.360	1

Screwdrivers



SET OF SCREWDRIVERS

Sets of screwdrivers U815-1 and U815-2 comprise 6 screwdrivers (3 flat screwdrivers and 3 cross-head screwdrivers PZ).

The set of screwdrivers U815-3 comprises 7 screwdrivers type Torx (T).

Code	Designation	Number of pieces	Shape	Sales unit
U815-1	SET OF 6 SCREWDRIVERS 1000V	6	-	3x100 4x125 5x150 PZ0 PZ1 PZ2 1
U815-2	SET OF 6 SCREWDRIVERS	6	-	4x100 5.5x100 6.5x125 PZ1 PZ2 PZ3 1
U815-3	SET OF 7 SCREWDRIVERS TORX	7	T6 T8 T10 T15 T20 T25 T30	- - 1

LV insulated tooling

Pliers

Application

These pliers are designed to facilitate the cable work for connection operations.

UNIVERSAL PLIER



U810-1 U810-2 U810-3 U810-4

PHONE PLIER



U810-5 U810-6

CUTTING PLIER



U810-7 U810-8

STRIPPING PLIER



U810-9

PLIER FOR INSULATED TERMINALS



U810-10

WATER PUMP PLIER



U810-11

SET OF 3 PLIERS

The set of 3 pliers comprises:
- a universal plier L=180mm
- a diagonal cutting plier L=160mm
- a stripping plier L=160mm



U810-12

Code	Designation	Length (mm)	Weight (kg)	Sales unit
U810-1	UNIVERSAL PLIER L=165mm 1000V	165	0.230	1
U810-2	UNIVERSAL PLIER L=180mm 1000V	180	0.270	1
U810-3	UNIVERSAL PLIER L=200mm 1000V	200	0.330	1
U810-4	UNIVERSAL PLIER L=210mm 1000V	210	0.280	1
U810-5	PHONE PLIER 1000V	200	0.210	1
U810-6	CURVED PHONE PLIER 1000V	200	0.210	1
U810-7	DIAGONAL CUTTING PLIER 1000V	160	0.210	1
U810-8	STRENGTHENED CUTTING PLIER 1000V	200	0.380	1
U810-9	STRIPPING PLIER 1000V	160	0.170	1
U810-10	PLIER FOR INSULATED TERMINALS	200	0.175	1
U810-11	WATER PUMP PLIER	254	0.350	1
U810-12	SET OF 3 PLIERS 1000V		0.620	1

Cutting

Application

These toolings are designed for cables and synthetic materials cut.

CABLE CUTTER



U811-1



U811-2
U811-3



U811-4

SCISSORS



U811-5

ANGLED KNIFE



U811-6

CUTTING PLIER FOR PLASTIC SADDLES



U811-7

PLASTIC PIPE CUTTER



U811-8

Code	Designation	Length (mm)	Weight (kg)	Sales unit
U811-1	CABLE CUTTER 1000V	250	0.500	1
U811-2	CABLE CUTTER WITH PAWL DIAM 32 1000V	260	0.600	1
U811-3	CABLE CUTTER WITH PAWL DIAM 52 1000V	280	0.800	1
U811-4	CABLE CUTTER WITH PAWL DIAM 70 1000V	300	0.900	1
U811-5	BIG BREACH SCISSORS 1000V	160	0.098	1
U811-6	ANGLED KNIFE 1000V	180	0.100	1
U811-7	CUTTING PLIER FOR PLASTIC SADDLES	150	0.100	1
U811-8	PLASTIC PIPE CUTTER 1000V	64	0.600	1

LV insulated tooling

Electrician sets



17 pieces - **U812-1**



26 pieces - **U812-2**



37 pieces - **U812-3**



31 pieces - **U812-5**



5 pieces - **U812-4**

Application

These sets offer several toolings designed for LV electrical equipment installation.

Code	Designation	Number of pieces	Weight (kg)	Sales unit
U812-1	ELECTRICIAN SET 17 PCS 1000V	17	3.60	1
U812-2	ELECTRICIAN SET 26 PCS 1000V	26	5.00	1
U812-3	ELECTRICIAN SET 37 PCS 1000V	37	9.00	1
U812-4	ELECTRICIAN TOOLINGS SET 5 PCS 1000V	5	0.75	1
U812-5	WRENCH SOCKETS SET 1/2" 1000V	31	10.00	1

Tool belts



U839-2



U839-1

Application

These belts make the fitter's job easier by giving an easy access to needed tools during the installation

Code	Designation	Weight (kg)	Sales unit
U839-1	SIMPLE TOOL BELT	0.500	1
U839-2	DOUBLE TOOL BELT	0.800	1

Measuring devices

Application

These devices are designed to perform test or control measurements in order to make sure of the right products installation.



U813-1

DIGITAL MULTIMETER

It measures direct or alternative current and voltage, resistance, electrical capacity, diodes and frequency.



U813-2

CLAMP AMMETER

The clamp measures current, voltage, resistance, temperature, diodes and electrical continuity.



U813-3

DIGITAL TESTER

It enables to perform voltage measurements from 0 up to 220V.

Code	Designation	Weight (kg)	Sales unit
U813-1	DIGITAL MULTIMETER	0.915	1
U813-2	CLAMP AMMETER	0.520	1
U813-3	DIGITAL TESTER 220V	0.040	1

Hydraulic crimping tool



F400



F407



F408

Application

These crimping tools are designed for the crimping of junction sleeves and lugs.

They are available in 2 versions:
- hydraulic type,
- electro-hydraulic type.



F424



F432



F420 - F421 - F422

Description

Hydraulic type:

- The ergonomic mobile handle enables the beginning of crimping by operating the tool with one hand.
- The developed force is 50kN maximum.
- The safety valve and audible "click" ensure efficient crimping and good protection of the hydraulic closing system.
- The ram retract mechanism is actuated by a release trigger.
- A 13mm stroke enables crimp connectors to be crimped between 6 and 150mm².
- The 180° rotating head facilitates use in any situations.
- The length is 365mm.
- The carrying case can contain one hydraulic crimping tool and up to 12 dies.

This hydraulic crimping tool meets the criteria of **NF C 20-130**.

Electro-hydraulic type:

- The developed force is 60kN maximum.
- The crimping time varies between 5 and 8 seconds depending on the section.
- The return is automatic after complete crimping.
- The autonomy is approximately 120 crimping operations.
- The F408 adaptor is used to assemble proposed dies.
- The product is delivered in a carrying case.

Code	Designation	Weight (kg)	Sales unit
CRIMPING TOOLS			
F400	50kN HYDRAULIC CRIMPING TOOL	2.350	1
F401	CARRYING CASE FOR 50kN HYDRAULIC CRIMPING TOOL	2.850	1
F407	60kN ELECTRO-HYDRAULIC CRIMPING TOOL	4.500	1
F408	HEXAGONAL DIE ADAPTOR	0.110	1
F409	BATTERY FOR F407	1.200	1
DIES FOR PREINSULATED SLEEVES			
F420	HEXAGONAL DIE TYPE E140	0.115	1
F421	HEXAGONAL DIE TYPE E173	0.115	1
F422	HEXAGONAL DIE TYPE E215	0.115	1
DIES FOR Al/Cu LUGS			
F424-140	HEXAGONAL DIE E140 Al/Cu SECTIONS 35+50	0.115	1
F424-173	HEXAGONAL DIE E173 Al/Cu SECTIONS 70+95+120	0.115	1
DIES FOR TUBULAR LUGS			
F432-4-120	HEXAGONAL DIE SECTIONS 4+120	0.115	1
F432-6-35	HEXAGONAL DIE SECTIONS 6+35	0.115	1
F432-10-50	HEXAGONAL DIE SECTIONS 10+50	0.115	1
F432-16-70	HEXAGONAL DIE SECTIONS 16+70	0.115	1
F432-25-95	HEXAGONAL DIE SECTIONS 25+95	0.115	1
F432-150	HEXAGONAL DIE SECTION 150	0.115	1
F432-185	HEXAGONAL DIE SECTION 185	0.115	1
F432-240	HEXAGONAL DIE SECTION 240	0.115	1

Other dies and hydraulic tools are available. Please contact us.



Installation video available on www.michaud-export.fr
(tab Documentation > Installation videos)

Alphabetical index

Designation	Pages
A	
A.B.C. accessories	68-69
Aerial sub-surface	
- sleeve	42-43
- connection	172-173
AMM concentrator	194-195
Anchoring	
- assembly	62 to 69
- network	62 to 65
- service	66-67
B	
Bare lug	54-55
BIC	70-71
Bolt and nut	76-77
Box	
- connection	26-27
- underground	154 to 167
BPMCC	170-171
BQC	74
Bracket	
- anchoring	62 to 69
- suspension	62 to 69
C	
Cable	
- aluminium	144-145
- copper	142-143
- cutter	225
- saddle	72-73
- tie	70-71
Clamp	
- ammeter	227
- anchoring	62 to 69
- connection	124 to 129
- cruciform	142-143
- suspension	62 to 69
(pole) Climbers	228-229
CMCC	136-137
Cold shrinkable seal	184-185
Comealong clamp	228-229
(earth) Conductor	138 to 145
Connector	
- « C » shape connector	132-133
- CB1d/CT	22-23
- CB2p/CT	24-25
- CBS/CT	14 to 17
- CDR/CNA	32-33
- CDR/CNU	32-33
- CDR/CT	32-33
- CDRS/CT	28-29
- CDRSp/CN	30-31
- CES/CT	36-37
- copper	132-133
- for BLL/BLX conductor	80
- for measure and short-circuiting	136-137
- fuse switch	94 to 97

Designation	Pages
- multipole	154 to 159
- network	28 to 35
- RDP/CNA	18-19 20-21 30-31
- RDP/CNU	18-19 20-21 30-31
- RDP1d/CT	23
- service	14 to 27
- single pole	160-161 166-167
- street light connector	36
- surge protection device connector	134-135
Connection box	26-27
Corrogated tube	78-79
Crimping tool	238-239
Cutout	
- cabinet	198-199
- sleeve	98 to 101
D	
(hexagonal) Die	238
Disconnection kit (earth sytem)	132-133
E	
Earth	
- electrode	124 to 129
- grid	130
- plate	130
- rod	124 to 129
- sytem	124 to 145
- tester	131
EBCD	206-207
EBCP	202 to 205
EJAS	172-173
End	
- cap	56 to 58 - 185
- connector	210-211
- E2R RF – E4R RF	184
- heat-shrinkable	58-59
F	
Flat washer	76-77
Fuse cartridge	
- gG	110-111
- AD	112-113
- NH1 and NH2	114-115
Fuse Switch Disconnecter (FSD)	
- single phase	88 to 93
- multi-phase	102 to 107
Fuse switch connector	94 to 97
G	
Gang FSD	102 to 107
Gel box	162-163
Gloves	216-217
(safety) Glasses	218-219
(pulling) Grip	230-231
Ground cutting blade	132-133

Alphabetical index

	Designation	Pages
H	Harness	222-223
	Heat-shrinkable material	58-59
	Helmet	218-219
	Hook for suspension	68-69
	Hot deep galvanised bolt and nut	76-77
I	Insulating	
	- mat	224-225
	- ladder	224-225
J	JRB	164-165
	Jumper clamp	132-133
L	(insulating) Ladder	224-225
	Linking cable	208-209
	Lug	
	- bare	54-55
	- preinsulated CPTAU	52-53
	- spin-welded terminal	54-55
	- tinned aluminium	54-55
- tubular	54-55	
M	Main connection box (MCB)	40-41
	(insulating) Mat	224-225
	MBS	40-41
	Mechanical fixing	60 to 79
	Meter board	190-191
	Meter circuit breaker	192-193
	MJPB	44-45
	MJPBAS	50-51
	MJPBS	50-51
	MJPT	46 to 49
	Modular distribution box	196-197
	Module REMIC	176 to 181
	Multimeter	237
	Multitap aerial connection box	26-27
N	Netting barrier	226-227
	Network preinsulated sleeve	42-43
	Network anchoring and suspension	62 to 65
	Nut	76-77
O	Operating stick (FSD)	108-190

	Designation	Pages
P	Parralel groove jaw	34-35
	PPE - Personal protective equipment	216-217
	Pigtail bolt	74
	Pit connector	100-101
	Plier	234
	Preinsulated	
	- sleeve	44 to 45
	- lug	52-53
	Protection	
	- accessories	68-69
	- plate (PPR)	182-183
Protective duct	78-79	
Pulley for A.B.C line	228-229	
Pulling grip and swivel	230-231	
Q	Quickgel	162-163
R	Reducing end connector	210-221
	REMIC	174 to 181
	Repairing junction kit	164-165
	Ring connector	154 to 159
	(earth) Rods	124 to 129
S	(cable) Saddle	70-71
	Safety shoes	220-221
	Screw	76-77
	Screwdriver	233
	Seal	200-201
	Sealing end cap and cover	56 to 58 - 185
	Service anchoring and suspension	66-67
	Service cable dismountable sleeve	40-41
	Set	
	- of bars REMIC	174-175
	- of preinsulated sleeves	48-49
	Sleeve	
	- aerial sub-surface preinsulated	50-51
	- cutout	98-99
- dismountable service	40-41	
- heat-shrinkable	58-59	
- network preinsulated	42-43	
- preinsulated	44 to 51	
(heat-shrinkable) Sheath	58-59	
Short circuiting		
- device	138 to 141	
- lost end	170-171	
- system	138-139	

Alphabetical index

Désignation	Pages
Strap.....	60-61
Street light	
- connection	36 to 39
- end cap.....	39
- set	38
Suspension	
- assembly	62 to 69
- bracket	62 to 69
- clamp.....	62 to 69
Swivel.....	230-231
T	
Tape for earth system	142-143
Test probe.....	16-17
Tether	222-223
Threaded shaft.....	76-77
(cable) Tie	72-73
Toolings	232 to 237
(corrugated) Tube	78-79
U	
Underground box	
- network	160-161 166-167
- service	154 to 159
Underground junction.....	168-169
W	
Warning	
- tape	182-183
- netting	226-227
(mechanical) Winch.....	228-229
Winder for stainless steel strap	60-61
Wire-strainer.....	228-229
Wooden pole climbers.....	228-229
Wrench (toolings)	223

Web site

Discover our latest news, catalogues, products range as well as information mediums to assist you in the use of our products.

www.michaud-export.com



LinkedIn

Join us on Michaud Export's LinkedIn network to follow the company's development and to share with us.

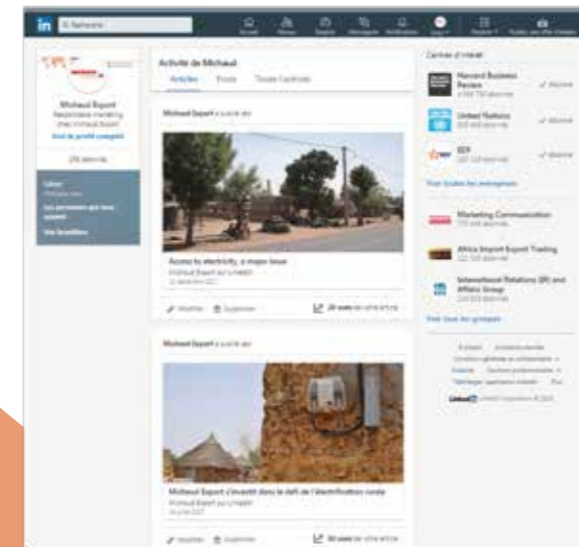

YouTube

Follow our YouTube channel in order to discover products implementation videos and this way facilitate your installations on the field.



Commercial reference index

BC	Code	Designation	Pages
	BC001	STREET LIGHT SET CAP EE2TF 6-16	38-39
BE	BE002	SHORT-CIRCUITING LOST END BPMCC 50-240	170-171
	BE004	SERVICE REPAIRING JUNCTION KIT JRB 10-50	164-165
ED	ED001	EARTH DISTRIBUTOR STRIP AL 5 TAPS	144-145
	ED002	EARTH DISTRIBUTOR STRIP AL 8 TAPS	144-145
	ED003	GROUND CUTTING BLADE AL STRIP	144-145
F	F001	CABLE TIE 9x123mm (100 pieces)	72-73
	F002	CABLE TIE 9x180mm (100 pieces)	72-73
	F003	CABLE TIE 9x265mm (100 pieces)	72-73
	F004	CABLE TIE 9x360mm (100 pieces)	72-73
	F005	CABLE TIE 9x500mm (100 pieces)	72-73
	F006	CABLE TIE 9x750mm (100 pieces)	72-73
	F009	NUMBERED SEAL WITH WIRE (100 pieces)	200-201
	F010	PLASTIC SEAL WITH UNIQUE NUMBER (100 PIECES)	200-201
	F013	IMPLEMENTATION TOOL FOR TIE	72-73
	F033	CABLE SADDLE - BRPV1	70-71
	F035	CABLE SADDLE - BRPV6	70-71
	F036	CABLE SADDLE - BRTV10	70-71
	F038	CABLE SADDLE - BRTV17	70-71
	F040	WALL TYPE STRAP SUPPORT WITH BRACKET TO STRIKE (box of 100)	72-73
	F041	WALL TYPE STRAP SUPPORT ATTACHED BY SCREW (box of 100)	72-73
	F043	CABLE SADDLE BIC 15/30 WITHOUT CABLE TIE	70-71
	F081	HANDLING GLOVES Size 10	216-217
	F100	HEAT-SHRINKABLE END E2R 10-35	58-59
	F101	HEAT-SHRINKABLE END E4R 10-35	58-59
	F102	HEAT-SHRINKABLE END E4R 50-150	58-59
	F103	HEAT-SHRINKABLE END E4R 240	58-59
	F109	HEAT-SHRINKABLE END CAP CRB 1.5-10	58-59
	F110	HEAT-SHRINKABLE END CAP CRB 10-25	58-59
	F111	HEAT-SHRINKABLE END CAP CRR 16-70	58-59
	F112	HEAT-SHRINKABLE END CAP CRR 150	58-59
	F113	HEAT-SHRINKABLE END CAP CRC 16-27	58-59
	F114	HEAT-SHRINKABLE END CAP CRC 26-48	58-59
	F115	HEAT-SHRINKABLE END CAP CRC 46-80	58-59
	F116	HEAT-SHRINKABLE END CAP CRR 240	58-59
	F119	HEAT-SHRINKABLE SHEATH GR 35-95 (10m)	58-59
F120	HEAT-SHRINKABLE SHEATH GR 10-35 (10m)	58-59	
F121	HEAT-SHRINKABLE SHEATH GR 50-150 (10m)	58-59	
F122	HEAT-SHRINKABLE SHEATH GR 240 (10m)	58-59	
F129	HEAT-SHRINKABLE SLEEVE FRM 30-150	58-59	

F	F130	HEAT-SHRINKABLE SLEEVE FRM 16-100	58-59
	F131	HEAT-SHRINKABLE SLEEVE FRM 25-100	58-59
	F132	HEAT-SHRINKABLE SLEEVE FRM 25-200	58-59
	F133	HEAT-SHRINKABLE SLEEVE FRM 30-250	58-59
	F134	HEAT-SHRINKABLE SLEEVE FRM 30-200	58-59
	F135	HEAT-SHRINKABLE SLEEVE FRM 35-150	58-59
	F136	HEAT-SHRINKABLE SLEEVE FRM 35-250	58-59
	F140	RINGED TUBE DIAMETER 16 (100m)	78-79
	F141	RINGED TUBE DIAMETER 20 (100m)	78-79
	F142	RINGED TUBE DIAMETER 25 (100m)	78-79
	F143	RINGED TUBE DIAMETER 32 (50m)	78-79
	F144	RINGED TUBE DIAMETER 40 (50m)	78-79
	F145	RINGED TUBE DIAMETER 50 (50m)	78-79
	F146	RINGED TUBE DIAMETER 63 (25m)	78-79
	F148	RINGED TUBE DIAMETER 90 (25m)	78-79
	F149	RINGED TUBE DIAMETER 110 (25m)	78-79
	F150	BIMETAL SPIN-WELDED BARE TERMINAL LUG 35mm ²	54-55
	F151	BIMETAL SPIN-WELDED BARE TERMINAL LUG 50mm ²	54-55
	F153	BIMETAL SPIN-WELDED BARE TERMINAL LUG 70mm ²	54-55
	F154	BIMETAL SPIN-WELDED BARE TERMINAL LUG 150mm ²	54-55
	F155	BIMETAL SPIN-WELDED BARE TERMINAL LUG 240mm ²	54-55
	F156	BIMETAL SPIN-WELDED BARE TERMINAL LUG 95mm ²	54-55
	F200	OPERATING STICK 2E - 1.5M (TERMINAL END U)	108-109
	F201	OPERATING STICK 2E - 2M (TERMINAL END U)	108-109
	F202	OPERATING STICK 2E - 3.2M (TERMINAL END U)	108-109
	F203	OPERATING STICK 2E - 5M (TERMINAL END U)	108-109
	F204	OPERATING STICK 3E - 4.5M (TERMINAL END U)	108-109
	F205	OPERATING STICK 3E - 5M (TERMINAL END U)	108-109
	F206	OPERATING STICK 3E - 6M (TERMINAL END U)	108-109
	F207	OPERATING STICK 1E - 1M	108-109
F208	PROTECTIVE COVER FOR OPERATING STICK	108-109	
F209	BORED TERMINAL END DISCONNECTOR / STICK	108-109	
F210	THREAD TERMINAL END DISCONNECTOR / STICK	108-109	
F213	TERMINAL END TYPE L DISCONNECTOR / STICK	108-109	
F220	DOUBLE SUSPENSION CLAMP BRACKET 12kN	64-65	
F221	EARTH ROD COPPER 254µm L = 2m DIAM 14 - 2 THREADS 5/8"	126-127	
F222	EARTH ROD COPPER 254µm L = 1.5m DIAM 14 - 2 THREADS 5/8"	126-127	
F223	EARTH ROD COPPER 50µm L = 2m DIAM 14 - 2 THREADS 5/8"	126-127	
F224	U BOLT CONNECTION CLAMP 150 ² ROD STAINLESS STEEL AND COPPER	124-125 126-127 128-129	
F226	EARTH ROD COPPER 50µm L = 1m DIAM 14	124-125	
F227	EARTH ROD COPPER 254µm L = 2m DIAM 14	124-125	
F228	SCREW FOR COUPLING FOR ROD DIAM 14 THREAD 5/8"	126-127	

Commercial reference index

	Code	Designation	Pages
F	F229	DRIVING SPIKE FOR ROD DIAM 12.7 + 14 UNTHREADED	124-125 126-127
	F230	EARTH ROD STAINLESS STEEL SELF-EXTENDABLE L = 1m DIAM 16	128-129
	F231	EARTH ROD STAINLESS STEEL SELF-EXTENDABLE L = 1.5m DIAM 16	128-129
	F232	EARTH ROD STAINLESS STEEL SELF-EXTENDABLE L = 2m DIAM 16	128-129
	F233	U BOLT CONNECTION CLAMP 50 ² ROD STAINLESS STEEL AND COPPER	124-125 126-127 128-129
	F234	CONNECTION CLAMP ROD STAINLESS STEEL AND COPPER	124-125 126-127 128-129
	F235	EARTH ROD COPPER 50 μ m L = 1.5m DIAM 14 - 2 THREADS 5/8"	126-127
	F236	THREADED COUPLING FOR ROD DIAM 14 THREAD 5/8"	126-127
	F237	DRIVING HEAD FOR ROD DIAM 14 THREADED + 17.2 UNTHREADED	124-125 126-127
	F238	DRIVING HEAD FOR ROD DIAM 12.7 + 14 UNTHREADED	124-125 126-127
	F239	DRIVING SPIKE FOR ROD DIAM 14 THREADED + 17.2 UNTHREADED	124-125 126-127
	F240	PULLEY WITH STRAP	228-229
	F241	PULLEY WITH HOOK	228-229
	F244	EARTH ROD COPPER 50 μ m L = 1.5m DIAM 14	124-125
	F245	EARTH ROD COPPER 50 μ m L = 2m DIAM 14	124-125
	F246	CONNECTION CLAMP ROD DIAM 14+17,2	124-125 126-127
	F249	EARTH ROD COPPER 254 μ m L = 1.5m DIAM 14	124-125
	F257	BARE CONDUCTOR COMEALONG 4-12mm	228-229
	F258	INSULATED CONDUCTOR COMEALONG 6-14mm	228-229
	F262	EARTH ROD COPPER 254 μ m L = 1.5m DIAM 17.2 - 2 THREADS 3/4"	126-127
	F265	THREADED COUPLING FOR ROD DIAM 17.2 THREAD 3/4"	126-127
	F269	SELF-SUPPORTED A.B.C. COMEALONG 4x95-150mm ²	228-229
	F296	EARTH ROD COPPER 50 μ m L = 1.5m DIAM 12.7 - 2 THREADS 9/16"	126-127
	F298	THREADED COUPLING FOR ROD DIAM 12.7 THREAD 9/16"	126-127
	F305	MULTIPLE ANCHORING BRACKET - CAM 25	66-67
	F311	PIGTAIL BOLT BQC 12x150 WITH 2 NUTS	74-75
	F312	PIGTAIL BOLT BQC 12x55 WITH 1 NUT	74-75
	F313	PIGTAIL BOLT BQC 12x90 WITH 2 NUTS	74-75
	F314	PIGTAIL BOLT BQC 12x110 CH WITH 1 NUT	74-75
	F315	PIGTAIL BOLT BQC 12x250 WITH 2 NUTS	74-75
	F316	PIGTAIL BOLT BQC 12x300 WITH 2 NUTS	74-75
	F317	PIGTAIL BOLT BQC 12x350 WITH 2 NUTS	74-75
	F318	PIGTAIL BOLT BQC 20x240 WITH 2 NUTS	74-75
F319	PIGTAIL BOLT BQC 20x100 WITH 2 NUTS	74-75	
F321	PIGTAIL BOLT BQC 20x250 WITH 2 NUTS	74-75	

F	F322	PIGTAIL BOLT BQC 16x250 WITH 2 NUTS	74-75	
	F323	PIGTAIL BOLT BQC 16x300 WITH 2 NUTS	74-75	
	F326	PIGTAIL BOLT BQC 20x400 WITH 2 NUTS	74-75	
	F330	NUT E12	74-75	
	F331	WASHER MG12	74-75	
	F345	ANCHORING HOOK PIGTAIL TQC 12x200	74-75	
	F400	50kN HYDRAULIC CRIMPING TOOL	238-239	
	F401	CARRYING CASE FOR 50kN HYDRAULIC CRIMPING TOOL	238-239	
	F407	60kN ELECTRO-HYDRAULIC CRIMPING TOOL	238-239	
	F408	HEXAGONAL DIE ADAPTOR	238-239	
	F409	BATTERY FOR F407	238-239	
	F420	HEXAGONAL DIE TYPE E140	238-239	
	F421	HEXAGONAL DIE TYPE E173	238-239	
	F422	HEXAGONAL DIE TYPE E215	238-239	
	F424	HEXAGONAL DIE Al/Cu	238-239	
	F432	HEXAGONAL DIE SECTIONS	238-239	
	F439	EARTH TESTER	130-131	
	F445	INSULATED RATCHET WRENCH HEXAGONAL 13/17mm	232-233	
	F448	WOOD POLE CLIMBERS 6 PEAKS DIAM	228-229	
	F450	BRUSH FOR CONDUCTOR WITH CASE	232-233	
	F460	INSULATED CROSS SPANNER 8-10-13-17mm	232-233	
	F860	WARNING NETTING 300m (width 0.1m)	182-183	
	F861	WARNING NETTING 100m (width 0.2m)	182-183	
	F862	WARNING NETTING 100m (width 0.3m)	182-183	
	F864	NETTING BARRIER	226-227	
	F865	WARNING TAPE RED/WHITE (ROLL 500m)	226-227	
	J	J041	1 BLUE 16mm ² LINKING CABLE L1200	208-209
		J042	1 BLACK 16mm ² LINKING CABLE L1200	208-209
		J045	1 BLUE 16mm ² LINKING CABLE L560	208-209
		J046	1 BLACK 16mm ² LINKING CABLE L530	208-209
		J047	1 BLUE 16mm ² LINKING CABLE L700	208-209
		J048	1 BLACK 16mm ² LINKING CABLE L700	208-209
		J132	1 BLUE 25mm ² LINKING CABLE L700	208-209
J133		1 BLACK 25mm ² LINKING CABLE L700	208-209	
J412		BLUE CABLE 16VK L 500	208-209	
J413		BLUE CABLE 16VK L 500	208-209	
J808		SET OF 2 16mm ² LINKING CABLES (1 BLUE + 1 BLACK)	208-209	
J809		SET OF 4 16mm ² LINKING CABLES (1 BLUE + 3 BLACK)	208-209	
K	K001	BLACK FLEXIBLE END CAP 10-50M	56-57 160-161	
	K002	BLACK FLEXIBLE END CAP 35-95	56-57	
	K003	BLACK FLEXIBLE END CAP 95-150	56-57	
	K004	HOLDING SPANNER CBS/RDP	232-233	

Commercial reference index

	Code	Designation	Pages
K	K005	INSULATED WEDGE SEPARATOR	232-233
	K006	EARTH SYSTEM EQUIPMENT	138-139
	K007	WEDGE SEPARATOR 200x15x9mm	154-155 156-157 158-159
	K007	INSULATED WEDGE SEPARATOR 200x15x9mm	232-233
	K008	SHORT-CIRCUITING EQUIPMENT 6 SOCKETS	138-139
	K009	SHORT-CIRCUITING EQUIPMENT 7 SOCKETS	138-139
	K010	GANG FSD EARTH SYSTEM DEVICE 3 POLES	140-141
	K012	GANG FSD EARTH SYSTEM DEVICE COPPER CABLE (2.5m / 35mm ²)	140-141
	K013	Cu CRIMPED TERMINAL LUG (E140) CPTAU 25	52-53
	K017	Cu CRIMPED TERMINAL LUG (E173) CPTAU 54	52-53
	K018	Cu CRIMPED TERMINAL LUG (E173) CPTAU 70	52-53
	K021	Cu CRIMPED TERMINAL LUG (E215) CPTAU 120	52-53
	K023	Cu CRIMPED TERMINAL LUG (E215) CPTAU 150	52-53
	K024	Cu TERMINAL LUG (E215) CPTAU 150	52-53
	K030	PREINSULATED SLEEVE (E140) MJPB 6	44-45
	K031	PREINSULATED SLEEVE (E140) MJPB 10-6	44-45
	K032	PREINSULATED SLEEVE (E140) MJPB 16-6	44-45
	K033	PREINSULATED SLEEVE (E140) MJPB 25-6	44-45
	K035	PREINSULATED SLEEVE (E140) MJPB 10	44-45
	K036	PREINSULATED SLEEVE (E140) MJPB 16-10	44-45
	K037	PREINSULATED SLEEVE (E140) MJPB 25-10	44-45
	K039	PREINSULATED SLEEVE (E140) MJPB 16	44-45
	K040	PREINSULATED SLEEVE (E140) MJPB 25-16	44-45
	K042	PREINSULATED SLEEVE (E140) MJPB 25	44-45
	K053	PREINSULATED SLEEVE (E140) MJPB 35-16	44-45
	K054	PREINSULATED SLEEVE (E140) MJPB 35-25	44-45
	K055	PREINSULATED SLEEVE (E140) MJPB 35	44-45
	K064	PREINSULATED SLEEVE (E140) MJPBAS 16-4M	50-51
	K065	PREINSULATED SLEEVE (E140) MJPBAS 16-6M	50-51
	K068	PREINSULATED SLEEVE (E140) MJPBAS 10-25M	50-51
K069	PREINSULATED SLEEVE (E140) MJPBAS 10-35M	50-51	
K070	PREINSULATED SLEEVE (E140) MJPBAS 16-16M	50-51	
K072	PREINSULATED SLEEVE (E140) MJPBAS 25-16M	50-51	
K073	PREINSULATED SLEEVE (E140) MJPBS 25M-25M	50-51	
K074	PREINSULATED SLEEVE (E140) MJPBAS 25-25M	50-51	
K075	PREINSULATED SLEEVE (E140) MJPBS 35M-35M	50-51	
K076	PREINSULATED SLEEVE (E140) MJPBAS 25-35M	50-51	
K078	PREINSULATED SLEEVE (E140) MJPBAS 16-25M	50-51	
K079	PREINSULATED SLEEVE (E140) MJPBAS 16-35M	50-51	

K	K080	PREINSULATED SLEEVE (E140) MJPBAS 16-21Cu	50-51
	K081	PREINSULATED SLEEVE (E140) MJPBAS 25-21Cu	50-51
	K082	PREINSULATED SLEEVE (E140) MJPBS 16M-21Cu	50-51
	K083	PREINSULATED SLEEVE (E140) MJPBS 25M-21Cu	50-51
	K084	PREINSULATED SLEEVE (E140) MJPBS 35M-21Cu	50-51
	K085	PREINSULATED SLEEVE (E140) MJPBS 16M-35M	50-51
	K086	PREINSULATED SLEEVE (E140) MJPBS 25M-35M	50-51
	K087	PREINSULATED SLEEVE (E140) MJPBS 21Cu-21Cu	50-51
	K091	DISMOUNTABLE SLEEVE PIERCING 4-50 / PIERCING 4-50	40-41
	K092	DISMOUNTABLE SLEEVE PIERCING 6-50M / STRIPPING 6-50M	40-41
	K096	DISMOUNTABLE SLEEVE PIERCING 6-35 / STRIPPING 4-35	40-41
	K098	DOUBLE TAP END CONNECTOR (6-35mm ²)	102-103 104-105 106-107
	K099	HSC PIERCING 6-35 / STRIPPING 4-35 / 4 BOLTS	40-41
	K101	PREINSULATED SLEEVE (E173) MJPT 16	46-47
	K103	PREINSULATED SLEEVE (E173) MJPT 25	46-47
	K106	PREINSULATED SLEEVE (E173) MJPT 35	46-47
	K108	PREINSULATED SLEEVE (E173) MJPT 50-25	46-47
	K109	PREINSULATED SLEEVE (E173) MJPT 50-35	46-47
	K110	PREINSULATED SLEEVE (E173) MJPT 50	46-47
	K114	PREINSULATED SLEEVE (E173) MJPT 54-50	46-47
	K115	PREINSULATED SLEEVE (E173) NEUTRAL MJPT 54	46-47
	K116	PREINSULATED SLEEVE (E173) NEUTRAL MJPT 70	46-47
	K117	PREINSULATED SLEEVE (E173) NEUTRAL MJPT 70-54	46-47
	K118	PREINSULATED SLEEVE (E173) MJPT 70-35	46-47
	K119	PREINSULATED SLEEVE (E173) MJPT 70-50	46-47
	K121	PREINSULATED SLEEVE (E173) MJPT 70	46-47
	K122	PREINSULATED SLEEVE (E173) MJPT 95-70	46-47
	K123	PREINSULATED SLEEVE (E173) MJPT 95	46-47
	K126	STRIPPING REDUCING END CONNECTOR 95-240	210-211
	K127	STRIPPING REDUCING END CONNECTOR 25-95	210-211
K128	STRIPPING REDUCING END CONNECTOR 6-50M	210-211	
K129	PIERCING REDUCING END CONNECTOR 6-50M PHASE L600	210-211	
K130	PIERCING REDUCING END CONNECTOR 6-50M NEUTRAL L600	210-211	
K131	PIERCING REDUCING END CONNECTOR 6-50M PHASE L300	210-211	
K132	PIERCING REDUCING END CONNECTOR 6-50M NEUTRAL L300	210-211	
K159	Cu TERMINAL LUG (E140) CPTAU 16	52-53	
K160	Cu TERMINAL LUG (E140) CPTAU 25	52-53	
K163	Cu TERMINAL LUG (E173) CPTAU 35	52-53	
K164	Cu TERMINAL LUG (E173) CPTAU 50	52-53	
K165	Cu TERMINAL LUG (E173) CPTAU 54	52-53	
K166	Cu TERMINAL LUG (E173) CPTAU 70	52-53	
K167	Cu TERMINAL LUG (E173) CPTAU 95	52-53	

Commercial reference index

	Code	Designation	Pages
K	K170	PREINSULATED SLEEVE (E215) MJPT 95	48-49
	K174	PREINSULATED SLEEVE (E215) MJPT 150-70	48-49
	K175	PREINSULATED SLEEVE (E215) MJPT 150	48-49
	K176	PREINSULATED SLEEVE (E215) MJPT 150-95	48-49
	K182	PREINSULATED SLEEVE (E215) NEUTRAL MJPT 95 FT	48-49
	K185	PREINSULATED SLEEVE (E215) NEUTRAL MJPT 150 FT	48-49
	K188	PREINSULATED SLEEVE (E215) MJPT 120	48-49
	K189	MECHANICAL PREINSULATED SLEEVE 25-95	42-43
	K191	MECHANICAL SUBSURFACE PREINSULATED SLEEVE SECTORAL 95-240	42-43
	K192	MECHANICAL SUBSURFACE PREINSULATED SLEEVE ROUND 150 / SECTORAL 240	42-43
	K193	MECHANICAL PREINSULATED SLEEVE ROUND 50-150	42-43
	K199	FUSE INSULATION PIERCING PIT CONNECTOR 100A (22x58) PERFO 6-50	100-101
	K210	FUSE SWITCH CONNECTOR 63A (22x58) PIERCING 150/35	96-97
	K219	CUTOUT SLEEVE 63A (22x58) STRIPPING 16-35	98-99
	K220	CUTOUT SLEEVE 50A (14x51) 2.5-16	98-99
	K221	CUTOUT SLEEVE 63A (22x58) PIERCING 6-35	98-99
	K223	FUSE CONNECTOR 20A (10.3x38) PIERCING 95/10	94-95
	K224	FUSE CONNECTOR 20A (10.3x38) PIERCING 95/16	94-95
	K228	FUSE CONNECTOR 20A (10.3x38) BARE Cu 95/10	94-95
	K229	FUSE CONNECTOR 20A (10.3x38) BARE Al 95/100	94-95
	K235	2 STAGES CONNECTOR RDP/CNU 95 SF	20-21
	K236	2 STAGES CONNECTOR RDP/CNA 95 SF	20-21
	K241	SPD IPC 15KA/275VAC 0.5m	134-135
	K242	SPD IPC 15KA/440VAC 0.5m	134-135
	K243	SPD SPARE PART 15KA/275VAC 0.5m	134-135
	K244	SPD SPARE PART 15KA/440VAC 0.5m	134-135
	K247	BLACK FLEXIBLE END CAP 95-240	28-29 56-57
	K250	IPC 50-157 BLL/BLX	80-81
	K251	IPC 50-241 BLL/BLX	80-81
	K254	CONNECTOR CDRSp/CN 120-70 ZF	30-31
	K257	CONNECTOR CDRSp/CN 120-150 ZF	30-31
	K258	CONNECTOR RDP/CNU 95 ZF	18-19
	K259	CONNECTOR RDP/CNA 95 ZF	18-19
	K267	FULLY SUPPORTED SUSPENSION CLAMP MOVABLE 2x16-2x25	64-65
	K270	FULLY SUPPORTED SUSPENSION CLAMP MOVABLE 4x16-4x25	64-65
	K271	FULLY SUPPORTED SUSPENSION CLAMP MOVABLE 4x120	64-65
K272	CABLE SADDLE - BRPF1	70-71	
K273	CABLE SADDLE - BRPF6	70-71	
K274	FULLY SUPPORTED SUSPENSION CLAMP MOVABLE 4x35-4x50	64-65	

K	K275	FULLY SUPPORTED SUSPENSION CLAMP MOVABLE 4x70	64-65
	K276	FULLY SUPPORTED SUSPENSION CLAMP MOVABLE 4x95	64-65
	K277	SUSPENSION ASSEMBLY [50-95] - ES 1500	62-63
	K278	ANCHORING BRACKET - CA 1500 - 1FP	62-63
	K280	SPARE PART - PS + LM 715	62-63
	K281	CABLE SADDLE - BRPF4	70-71
	K282	CABLE SADDLE - BRPF9	70-71
	K283	FUSE SUSPENSION ASSEMBLY [50-70] - ESF 715	62-63
	K288	FULLY SUPPORTED ANCHORING CLAMP 4x50-95	64-65
	K291	SINGLE PHASE FSD 100A (22x58) PIERCING 6-95	90-91
	K292	SINGLE PHASE FSD 160A (NH 00) PIERCING 6-95	92-93
	K293	TRIPLE POLE FSD 160A (NH 00) PIERCING 6-95	104-105
	K294	QUADRUPLE POLE FSD 160A (NH 00) PIERCING 6-95	106-107
	K295	PLASTIC ADAPTOR FOR SINGLE PHASE FSD BRACKET	88-89 90-91 92-93
	K296	DOUBLE TRIPLE POLE FSD 160A (NH 00) PIERCING 6-95	104-105
	K297	METAL BRACKET FOR SINGLE PHASE FSD	88-89 90-91 92-93
	K298	DOUBLE POLE FSD 160A (NH 00) PIERCING 6-95	102-103
	K300	SERVICE CABLE CLAMP 3/4 x 16-35 TYPE CLOSED EYE - PA 35	66-67
	K301	SERVICE CABLE CLAMP 3/4 x 16-35 TYPE HOOK - PA 35	66-67
	K302	FULLY SUPPORTED ANCHORING CLAMP 4x120	64-65
	K306	ANCHORING CLAMP - PA 1500	62-63
	K307	ANCHORING CLAMP WITH HANDLE - PA 25	66-67
	K308	ANCHORING BRACKET - CA 1500 - 2FP	62-63
	K309	ANCHORING CLAMP WITH ADJUSTABLE HOOK - PACR 25	66-67
	K313	CONNECTOR CDR/CS 50-95	166-167
	K314	EARTH SYSTEM CONNECTOR 50-95 / 25	166-167
	K317	CONNECTOR CBS/CS 240	160-161
	K318	CONNECTOR CBS NEUTRAL/CS	160-161
	K322	CONNECTOR CBS/CT 25 ZF - ERDF	14-15
	K323	CONNECTOR CBS/CT 70 ZF - ERDF	14-15
	K324	CONNECTOR CBS/CT 150 ZF - ERDF	14-15
	K326	CONNECTOR CES/CT 70 ZF	36-37
	K330	CONNECTOR CBS/CT 150 ZF	14-15
	K331	CONNECTOR CBS/CT 70 ZF	14-15
	K332	CONNECTOR CBS/CT 95 ZF	14-15
	K336	CONNECTOR CBS/CT 95 TEST PROBE ZF	16-17
K337	CONNECTOR CBS/CT 150 TEST PROBE ZF	16-17	
K338	CONNECTOR CBS/CT 95 TEST PROBE SF	16-17	
K342	CONNECTOR CDR/CT 2S 150-70 ZF	32-33	
K343	CONNECTOR CDR/CT 2S 150-150 ZF	32-33	
K346	PIERCING CONNECTOR CB 4p/CT 95 SF	24-25	

Commercial reference index

	Code	Designation	Pages
K	K354	CONNECTOR CDRS/CT 150-95 SF	28-29
	K355	CONNECTOR CDRS/CT 150-95 ZF	28-29
	K356	CONNECTOR CDRS/CT 150-150 ZF	28-29
	K360	CONNECTOR CDR NEUTRAL/CS 50-95	166-167
	K361	CONNECTOR CMCC/CT 95 ZF	136-137
	K362	CONNECTOR CMCC/CT 25 ZF	136-137
	K363	CONNECTOR CMCC/CT 70 ZF	136-137
	K364	CONNECTOR CMCC/CT 150 VZ	136-137
	K365	CONNECTOR CDRS/CT 95-95 ZF	28-29
	K366	CONNECTOR CDRS/CT AL 150-150 ZF	28-29
	K368	SHORT-CIRCUITING AND EARTH SYSTEM SOCKET	136-137
	K376	CONNECTOR CDR/CNA 2S 70 ZF	32-33
	K377	CONNECTOR CDR/CNA 2S 150 ZF	32-33
	K378	CONNECTOR CDR/CNU 2S 70 ZF	32-33
	K379	CONNECTOR CDR/CNU 2S 150 ZF	32-33
	K381	CONNECTOR CDRS/CT 240-240 ZF (without cap)	28-29
	K383	CONNECTOR CDR/CS 50-240	166-167
	K384	CONNECTOR CDR/CS 50-240/50-150	166-167
	K389	PIERCING CONNECTOR CB 2p/CT 150 SF	24-25
	K390	PIERCING CONNECTOR CB 2p/CT 150 ZF	24-25
	K391	STRIPPING CONNECTOR CB 2d/CT 150 ZF	24-25
	K392	PIERCING CONNECTOR CB 2p/CT 70 ZF	24-25
	K393	STRIPPING CONNECTOR CB 2d/CT 70 ZF	24-25
	K394	PIERCING CONNECTOR CB 2p/CT 95 ZF	24-25
	K396	STRIPPING CONNECTOR RDP 1d/CNU 95	22-23
	K397	PIERCING CONNECTOR CB 1d/CT 95	22-23
	K416	STREET LIGHT SET	38-39
	K419	CONNECTOR CB2p/CS 240	160-161
	K420	CONNECTOR CB2p NEUTRAL/CS	160-161
	K421	GABARIT FOR ALIGNMENT LATH	190-191
	K422	ALIGNMENT LATH (Length 3m)	190-191
	K424	SUPPORT FOR ELECTRIC METER + COVER	190-191
	K425	COVER (FOR SUPPORT FOR ELECTRIC METER)	190-191
	K434	PIERCING CONNECTOR CB 4p/CT 150 SF	24-25
	K439	CONNECTOR CES/CT 95 ZF	36-37
	K440	CONNECTOR CES/CT 95 SF	36-37
	K441	CONNECTOR CBS/CT 95 SF	14-15
	K442	CONNECTOR CBS/CT 150/1.5-25 SF	14-15
	K443	CONNECTOR CBS/CT 150/6-35 SF	14-15

K	K444	CONNECTOR CDR/CT 2S 150-150 SF	32-33
	K445	CONNECTOR CDRS/CT 95-95 SF	28-29
	K446	CONNECTOR CDRS/CT 150-150 SF	28-29
	K449	4 POLES SERVICE CONNECTOR 150 / 1x35	154-155
	K450	MULTIPOLE CONNECTOR 150 + UNDERGROUND BOX	154-155
	K451	SINGLE PHASE MCB + 2 K096	40-41
	K455	THREE PHASE MCB + 4 K096	40-41
	K459	4 POLES SERVICE CONNECTOR 240 / 2x35	156-157
	K470	CONNECTOR RDP/CNU 95 SF	18-19
	K471	CONNECTOR RDP/CNA 95 SF	18-19
	K472	CONNECTOR RDP/CNU 120-95 SF	30-31
	K473	CONNECTOR RDP/CNA 120-95 SF	30-31
	K474	CONNECTOR RDP/CNU 240-150 SF	30-31
	K475	CONNECTOR RDP/CNA 240-150 SF	30-31
	K491	SINGLE PHASE FSD 100A (22x58) PIERCING 6-35	88-89
	K492	NUMBER PLATE FOR FSD K491 / CABLE	88-89
	K503	SET OF SLEEVES (E173) EJPT 35-54.6	46-47
	K504	SET OF SLEEVES (E173) EJPT 50-54.6	46-47
	K505	SET OF SLEEVES (E173) EJPT 70-54.6	46-47
	K506	SET OF SLEEVES (E173) EJPT 70-35-54.6	46-47
	K507	SET OF SLEEVES (E173) EJPT 70-50/54.6	46-47
	K509	SET OF SLEEVES (E215) EJPT 150-70/70-54.6	48-49
	K510	SET OF SLEEVES (E215) EJPT 150-70/150-70	48-49
	K532	CONNECTOR CBS/CT 95 ZF A	14-15
	K555	CONNECTOR CDRS/CT 95-95 ZF	28-29
	K569	MECHANICAL SUBSURFACE PREINSULATED SLEEVE 150-300	42-43
	K594	PIERCING CONNECTOR CB 2p/CT 95 ZF A	24-25
	K610	CAST JUNCTION BOX 95-95 (JNC)	166-167
	K612	CAST JUNCTION BOX 240-240 (JNC)	166-167
	K630	SINGLE-OUTLET CAST BOX (SDC)	160-161
	K631	DOUBLE-OUTLET CAST BOX (DDC)	160-161
	K640	SERVICE BOX MULTI-CONNECTION INJECTED 240-35	156-157
	K642	4 POLES SERVICE CONNECTOR 300 / 2x35	158-159
	K645	SERVICE BOX MULTI-CONNECTION CAST 240-35	156-157
	K646	SERVICE BOX MULTI-CONNECTIONS CAST + CONNECTOR 300 ²	158-159
	K654	SET OF 100 EYES 25x25	60-61
	K655	SET OF 100 EYES 25x40	60-61
	K656	SET OF 100 EYES 25x60	60-61
	K699	SET OF SLEEVES (E173) EJPT 70-50/70-54.6	46-47
	K700	SET OF SLEEVES (E173) EJPT 70/70-54.6	46-47
	K701	SET OF SLEEVES (E173) EJPT 70-70	46-47
	K702	SET OF SLEEVES (E215) EJPT 150-70/70-70	48-49
	K716	AMM CONCENTRATOR DATA SUPPLY KIT + LINKING CABLE L=6m	194-195

Commercial reference index

	Code	Designation	Pages
K	K719	AMM CONCENTRATOR DATA SUPPLY KIT + LINKING CABLE L=10m	194-195
	K910-B	BLUE SEAL (box of 100 pieces)	200-201
	K910-R	RED SEAL (box of 100 pieces)	200-201
	K910-W	WHITE SEAL (box of 100 pieces)	200-201
	K920	50m CARDBOARD WINDER STAINLESS STEEL STRAP 10x0.4mm	60-61
	K921	50m CARDBOARD WINDER STAINLESS STEEL STRAP 10x0.7mm	60-61
	K922	50m CARDBOARD WINDER STAINLESS STEEL STRAP 20x0.4mm	60-61
	K923	50m CARDBOARD WINDER STAINLESS STEEL STRAP 20x0.7mm	60-61
	K930	50m WINDER STAINLESS STEEL STRAP 10x0.4mm	60-61
	K931	50m WINDER STAINLESS STEEL STRAP 10x0.7mm	60-61
	K932	50m WINDER STAINLESS STEEL STRAP 20x0.4mm	60-61
	K933	50m WINDER STAINLESS STEEL STRAP 20x0.7mm	60-61
	K951-20	SET OF 100 BUCKLES FOR 20mm STRAP	60-61
	K953	SET OF 100 REINFORCED BUCKLES FOR 10mm STRAP	60-61
	K955	SET OF 100 REINFORCED BUCKLES FOR 20mm STRAP	60-61
	K957	PROTECTION TAPE FOR 10mm STRAP (10m length)	60-61
	K958	PROTECTION TAPE FOR 20mm STRAP (10m length)	60-61
	K959	BINDING TOOL WHEEL TYPE FOR STRAP	60-61
	K960	BINDING TOOL RATCHET TYPE FOR STRAP	60-61
	K961	CUTTING TOOL FOR STRAP	60-61
K963	CARRYING CASE FOR STRAP TOOLS	60-61	
K968	STRAP FOLDING PLIER	60-61	
L	L024	CONTACTAL N190 NEUTRAL GREASE - TUBE OF 100g	232-233
	L100	CABLE SEALING END E2R RF 10-35 SILICONE	232-233
	L101	CABLE SEALING END E4R RF 10-35 SILICONE	232-233
	L102	CABLE SEALING END E4R RF 35-70 SILICONE	232-233
	L103	CABLE SEALING END E4R RF 95-240 SILICONE	232-233
	L112	SEAL CAP CRC RF 8-16	232-233
	L113	SEAL CAP CRC RF 16-27	232-233
	L114	SEAL CAP CRC RF 26-48	232-233
	L115	SEAL CAP CRC RF 46-80	232-233
	L220	EBCPAU COVER CLASS II	204-205
	L260	CONNECTOR Cu 10-70 (SF + SH)	132-133
	L261	CONNECTOR Cu 10-70 (SF)	132-133
	L277	SINGLE PHASE FSD 160A (NH 00) STRIPPING 6-120	92-93
	L278	DOUBLE POLE FSD 160A (NH 00) STRIPPING 6-120	102-103
	L281	QUADRUPLE POLE FSD 160A (NH 00) STRIPPING 6-120	106-107
	L284	TRIPLE POLE FSD 160A (NH 00) STRIPPING 6-120	104-105
	L297	FUSE CARRIER (Size 00) WITH BLOWN FUSE INDICATOR	92-93
	L298	FUSE CARRIER (Size 00) WITH DISPLAY & BLOWN FUSE INDICATORS	92-93

L	L304	FIXING CLAMP - PF 25	66-67
	L306	SCREW - M10	66-67
	L307	WHITE SHEAR HEAD SCREW FOR K099	40-41
	L311	SERVICE ANCHORING CLAMP GS - PA 25	66-67
	N	N106	GROUND CUTTING BLADE ALUMINIUM WITH BOX
N107		GROUND CUTTING BLADE BARE AL	144-145
N108		BOX FOR GROUND CUTTING BLADE	144-145
N109		BOX OF 25 LABELS AL CABLE	144-145
N273		PROTECTIVE DUCT GPT 30.30 GREY	78-79
N274		PROTECTIVE DUCT GPC 35.35 GREY	78-79
N275		PROTECTIVE DUCT GPC 60.60 GREY	78-79
N276		PROTECTIVE DUCT GPC 90.90 GREY	78-79
N277		PROTECTIVE DUCT GPC 120.120 GREY	78-79
N278		PROTECTIVE DUCT GPC 140.50 GREY	78-79
N297		METAL PROTECTIVE DUCT GPC 35.35mm	78-79
N298		METAL PROTECTIVE DUCT GPC 60.60mm	78-79
N299		METAL PROTECTIVE DUCT GPC 90.90mm	78-79
N300		METAL PROTECTIVE DUCT GPC 120.120mm	78-79
N708		QUICKGEL 125C	162-163
N709		QUICKGEL 32.5C	162-163
N710		QUICKGEL 506C	162-163
N711		QUICKGEL 516C	162-163
N712		QUICKGEL 425P	162-163
N713		QUICKGEL 525P	162-163
N714	QUICKGEL 516YC	162-163	
N715	QUICKGEL 525YC	162-163	
N716	QUICKGEL 100	162-163	
N717	QUICKGEL 500	162-163	
N718	QUICKGEL 510	162-163	
N719	QUICKGEL 520	162-163	
N733	CABLE SADDLE BIC 15/30	70-71	
N734	CABLE SADDLE BIC 30/50	70-71	
N735	CABLE SADDLE BIC 50/90	70-71	
P	P053	CUTOUT CABINET BIPOLAR 90A	198-199
	P054	CUTOUT CABINET TETRAPOLAR 60A	198-199
	P070	AMM STATION CONCENTRATOR BOARD	194-195
	P100	CUTOUT CABINET 2A NEUTRAL TUBE	198-199
	P130	FUSE CARTRIDGE NH2 125A 160mm	114-115
	P131	FUSE CARTRIDGE NH2 200A 160mm	114-115
	P132	FUSE CARTRIDGE NH2 250A 160mm	114-115
	P134	FUSE CARTRIDGE NH2 400A 160mm	114-115
	P219	EBCP 50 SECT-16 BLACK L700 CLASS II	204-205
	P220	SET OF 3 EBCP 50 SECT-16 BL/BR/GR L375	204-205

Commercial reference index

P

Code	Designation	Pages
P221	EBCP 50 SECT-16 BLUE L375 CLASS II	204-205
P222	EBCP 6-35/16 BLACK L500	202-203
P223	EBCP 6-35/16 BLUE L500	202-203
P226	EBCP P221 + YELLOW/GREEN EARTH SYSTEM L345	204-205
P227	EBCP P221 + YELLOW/GREEN EARTH SYSTEM L800	204-205
P228	EBCP 50 SECT-16 YELLOW/GREEN L800	204-205
P236	FUSE CARTRIDGE SIZE 00 100A	112-113 114-115
P237	HANDLE FOR FUSES SIZE 00 - SIZE 2	112-113 114-115
P238	NEUTRAL BLADE CONTACT NH2 115mm	114-115
P239	NEUTRAL BLADE CONTACT NH2 160mm	114-115
P240	NEUTRAL BLADE CONTACT SIZE 00	112-113
P241	FUSE CARTRIDGE SIZE 00 AD 30A	112-113
P242	FUSE CARTRIDGE SIZE 00 AD 45A	112-113
P243	FUSE CARTRIDGE SIZE 00 AD 60A	112-113
P244	FUSE CARTRIDGE SIZE 00 AD 90A	112-113
P340	AL/CU EARTH ADAPTOR 35-25	144-145
P414	STREET LIGHT END CAP EE4TF 6-16	38-39
P414	STREET LIGHT END CAP EE3TF 6-16	38-39
P419	STREET LIGHT END CAP EE5TF 6-16	38-39
P431	INSULATION PIERCING AERIAL CONNECTION BOX 3 OUTLETS	26-27
P432	STRIPPING AERIAL CONNECTION BOX 3 OUTLETS	26-27
P435	STRIPPING AERIAL CONNECTION BOX 7 OUTLETS	26-27
P446	EBCP 6-35/16 BLACK L235	202-203
P447	EBCP 6-35/16 BLUE L235	202-203
P448	EBCP 10-35/25 BLACK L190	202-203
P449	EBCP 10-35/25 BLUE L190	202-203
P474	COVER FOR METER AND CIRCUIT-BREAKER BOARD	192-193
P475	METER AND CIRCUIT-BREAKER BOARD	192-193
P620	SET OF 2 EBCD 35-25 (1 BLACK + 1 BLUE)	206-207
P621	SET OF 4 EBCD 35-25 (3 BLACK + 1 BLUE)	206-207
P641	SEALABLE SCREW COVER (2mm diameter)	200-201
P642	SEALABLE SCREW COVER + 5x30 VBA SCREW	200-201
P648	SET OF 2 EBCP 6-35/16 (1 BLACK + 1 BLUE) L235	202-203
P649	SET OF 2 EBCP 10-35/25 (1 BLACK + 1 BLUE) L190	202-203
P650	SET OF 4 EBCP 10-35/25 (3 BLACK + 1 BLUE) L190	202-203
P651	SET OF 4 EBCP 6-35/16 (3 BLACK + 1 BLUE) L235	202-203
P660	SET OF 16mm ² EBCPAU LINKING CABLE SINGLE 2 PIERCINGS	208-209
P662	SET OF 16mm ² EBCPAU LINKING CABLE THREE-PHASE 2 PIERCINGS	208-209

P

Q

R

U

P731	EBCP 50 SECT-16 BLACK L375 CLASS II	204-205
P732	EBCP 50 SECT-16 GREY L375 CLASS II	204-205
P733	EBCP 50 SECT-16 BROWN L375 CLASS II	204-205
Q591	DISTRIBUTION BOX WITH 1 MODULE	196-197
Q592	DISTRIBUTION BOX WITH 2 MODULES	196-197
Q594	DISTRIBUTION BOX WITH 4 MODULES	196-197
Q596	DISTRIBUTION BOX WITH 6 MODULES	196-197
Q599	DISTRIBUTION BOX WITH 9 MODULES	196-197
Q600	REMIC SET OF BARS SUPPORT 300	174-175
Q601	REMIC SET OF BARS SUPPORT 450	174-175
Q602	REMIC SET OF BARS SUPPORT 600	174-175
Q603	REMIC MODULE TYPE NETWORK RRD 50-240 (1 neutral + 3 phases)	178-179
Q604	REMIC 4-TYPE INSULATION BLOC MODULE	178-179
Q606	REMIC MODULE TYPE FUSE SERVICE THREE PHASE 60A RBPT	176-177
Q607	REMIC MULTITAP CONNECTION MODULE RBD (1 NEUTRAL + 3 PHASES)	176-177
Q608	REMIC MODULE TYPE FUSE SERVICE SINGLE PHASE 90A RBPM	176-177
Q609	REMIC MODULE TYPE FUSE SERVICE SINGLE PHASE 60A RBPM	176-177
Q610	REMIC MULTITAP CONNECTION MODULE SINGLE PHASE (1 NEUTRAL + 1 PHASE)	176-177
Q612	REMIC MODULE TYPE NETWORK RRD 50-150 (1 neutral + 3 phases)	178-179
Q613	REMIC MODULE RRC 400A	180-181
Q614	REMIC MODULE RRCP 400A / 200A	180-181
Q618	REMIC STANDARD S20 CABINET FRAME	174-175
Q619	REMIC STANDARD S15 CABINET FRAME	174-175
Q979	EARTH DISTRIBUTOR AL 6 TAPS	144-145
Q984	ALUMINIUM EARTH CABLE 252 100M	144-145
Q985	ALUMINIUM EARTH CABLE 352 100M	144-145
Q986	ALUMINIUM EARTH CABLE 502 50M	144-145
R041	250x550 PANEL FOR THREE PHASE METER + CIRCUIT-BREAKER WITHOUT LOGO	192-193
R043	330x330 PANEL FOR THREE PHASE METER + CIRCUIT-BREAKER WITHOUT LOGO	192-193
R092	250x550 PANEL FOR THREE PHASE METER + CIRCUIT-BREAKER + COVER	192-193
R112	COVER FOR 250x550 PANEL	192-193
R139	COVER FOR 330x330 PANEL	192-193
U001	C CONNECTOR 4-4	132-133
U002	C CONNECTOR 10-6	132-133
U003	C CONNECTOR 25-6	132-133
U004	C CONNECTOR 25-10	132-133
U005	C CONNECTOR 25-25	132-133
U006	C CONNECTOR 35-25	132-133
U007	C CONNECTOR 35-35	132-133
U008	C CONNECTOR 70-35	132-133
U009	C CONNECTOR 70-70	132-133
U010	C CONNECTOR 95-35	132-133

Commercial reference index

U

Code	Designation	Pages
U011	C CONNECTOR 95-70	132-133
U012	C CONNECTOR 95-95	132-133
U013	C CONNECTOR 120-120	132-133
U014	C CONNECTOR 185-95	132-133
U015	C CONNECTOR 150-150	132-133
U016	C CONNECTOR 185-185	132-133
U020	JUMPER CLAMP 6-16mm ²	132-133
U021	JUMPER CLAMP 10-50mm ²	132-133
U022	JUMPER CLAMP 50-70mm ²	132-133
U023	JUMPER CLAMP 70-95mm ²	132-133
U024	JUMPER CLAMP 95-150mm ²	132-133
U030	TUBULAR LUG 25-29	132-133
U031	EARTH SYSTEM DISCONNECTION KIT 25-29	132-133
U034	T SHAPE GROUND CUTTING BLADE	132-133
U035	HIGH GROUND CUTTING BLADE	132-133
U036	LOW GROUND CUTTING BLADE	132-133
U037	ALU LUG TINNED	54-55
U050	BARE COPPER CABLE 10mm ² - 500m drum	142-143
U051	BARE COPPER CABLE 16mm ² - 500m drum	142-143
U052	BARE COPPER CABLE 25mm ² - 500m drum	142-143
U053	BARE COPPER CABLE 29mm ² - 500m drum	142-143
U054	BARE COPPER CABLE 35mm ² - 500m drum	142-143
U055	BARE COPPER CABLE 50mm ² - 500m drum	142-143
U056	BARE COPPER CABLE 70mm ² - 500m drum	142-143
U057	BARE COPPER CABLE 95mm ² - 500m drum	142-143
U058	BARE COPPER CABLE 120mm ² - 500m drum	142-143
U059	BARE COPPER CABLE 150mm ² - 500m drum	142-143
U060	BARE COPPER CABLE 185mm ² - 500m drum	142-143
U061	BARE COPPER CABLE 240mm ² - 500m drum	142-143
U062	BARE COPPER CABLE 300mm ² - 500m drum	142-143
U063	INSULATED COPPER CABLE 6mm ² - 500m drum	142-143
U064	INSULATED COPPER CABLE 10mm ² - 500m drum	142-143
U065	INSULATED COPPER CABLE 16mm ² - 500m drum	142-143
U066	INSULATED COPPER CABLE 25mm ² - 500m drum	142-143
U068	INSULATED COPPER CABLE 35mm ² - 500m drum	142-143
U069	INSULATED COPPER CABLE 50mm ² - 500m drum	142-143
U070	INSULATED COPPER CABLE 70mm ² - 500m drum	142-143
U071	INSULATED COPPER CABLE 95mm ² - 500m drum	142-143
U072	INSULATED COPPER CABLE 120mm ² - 500m drum	142-143

U

U073	INSULATED COPPER CABLE 150mm ² - 500m drum	142-143
U074	INSULATED COPPER CABLE 185mm ² - 500m drum	142-143
U075	INSULATED COPPER CABLE 240mm ² - 500m drum	142-143
U076	INSULATED COPPER CABLE 300mm ² - 500m drum	142-143
U077	COPPER TAPE 20x3 L=100m	142-143
U078	COPPER TAPE 25x3	142-143
U080	COPPER BONDED STEEL TAPE 20x3 L=60m	142-143
U081	COPPER BONDED STEEL TAPE 25x3 L=40m	142-143
U082	COPPER BONDED STEEL TAPE 25x4 L=30m	142-143
U083	COPPER BONDED STEEL TAPE 30x3 L=40m	142-143
U084	COPPER BONDED STEEL TAPE 30x4 L=30m	142-143
U085	COPPER BONDED STEEL TAPE 40x4 L=20m	142-143
U086	TINNED COPPER BONDED STEEL TAPE 20x3 L=60m	142-143
U087	TINNED COPPER BONDED STEEL TAPE 25x3 L=40m	142-143
U088	TINNED COPPER BONDED STEEL TAPE 25x4 L=30m	142-143
U089	TINNED COPPER BONDED STEEL TAPE 30x3 L=40m	142-143
U090	TINNED COPPER BONDED STEEL TAPE 30x4 L=30m	142-143
U091	TINNED COPPER BONDED STEEL TAPE 40x4 L=30m	142-143
U092	STAINLESS STEEL CRUCIFORM CLAMP ROD DIAM 12.7 ET 14	142-143
U093	STAINLESS STEEL CRUCIFORM CLAMP ROD DIAM 17.2	142-143
U100-4	FEUILLARD ACIER GALVA 30x4 L=50m	142-143
U101-4	FEUILLARD ACIER GALVA 40x4 L=38m	142-143
U184	COPPER EARTH PLATE 500x500x2	130-131
U185	COPPER EARTH PLATE 500x500x3	130-131
U186	COPPER EARTH PLATE 500x1000x2	130-131
U187	COPPER EARTH PLATE 500x1000x3	130-131
U188	COPPER EARTH GRID 1000x1000x2	130-131
U189	COPPER EARTH GRID 2000x1000x2	130-131
U190	COPPER EARTH GRID 3000x1000x2	130-131
U191	CONNECTION CLAMP GALVA ROD DIAM 16	128-129
U192	CONNECTION BOLT AND NUT ROD CROSS-SHAPED	128-129
U193	CONNECTION CLAMP 25mm ² ZINC BRASS ROD CROSS-SHAPED	128-129
U194	CONNECTION CLAMP 50mm ² ZINC BRASS ROD CROSS-SHAPED	128-129
U195	EARTH ROD GALVA L = 1m DIAM 16	128-129
U196	EARTH ROD GALVA L = 1.5m DIAM 16	128-129
U197	EARTH ROD GALVA L = 2m DIAM 16	128-129
U198	EARTH ROD GALVA L = 1.5m DIM 50x50x3	128-129
U199	EARTH ROD GALVA L = 1m DIAM 25	128-129
U200	EARTH ROD GALVA L = 1.5m DIAM 25	128-129
U201	EARTH ROD GALVA L = 2m DIAM 25	128-129
U203	EARTH ROD COPPER 50µm L = 1m DIAM 12.7	124-125
U204	EARTH ROD COPPER 50µm L = 1.5m DIAM 12.7	124-125
U205	EARTH ROD COPPER 50µm L = 2m DIAM 12.7	124-125

Commercial reference index

Code	Designation	Pages
U206	EARTH ROD COPPER 254µm L = 1m DIAM 14	124-125
U207	EARTH ROD COPPER 254µm L = 3m DIAM 14	124-125
U208	EARTH ROD COPPER 254µm L = 1m DIAM 17.2	124-125
U209	EARTH ROD COPPER 254µm L = 1.5m DIAM 17.2	124-125
U210	EARTH ROD COPPER 254µm L = 2m DIAM 17.2	124-125
U211	EARTH ROD COPPER 254µm L = 3m DIAM 17.2	124-125
U212	EARTH ROD COPPER 350µm L = 1m DIAM 17.2	124-125
U213	EARTH ROD COPPER 350µm L = 1.5m DIAM 17.2	124-125
U214	EARTH ROD COPPER 350µm L = 2m DIAM 17.2	124-125
U215	EARTH ROD COPPER 50µm L = 1m DIAM 12.7 - 2 THREADS 9/16"	126-127
U216	EARTH ROD COPPER 50µm L = 2m DIAM 12.7 - 2 THREADS 9/16"	126-127
U217	EARTH ROD COPPER 50µm L = 1m DIAM 14 - 2 THREADS 5/8"	126-127
U218	EARTH ROD COPPER 254µm L = 1m DIAM 14 - 2 THREADS 5/8"	126-127
U219	EARTH ROD COPPER 254µm L = 3m DIAM 14 - 2 THREADS 5/8"	126-127
U220	EARTH ROD COPPER 254µm L = 1m DIAM 17.2 - 2 THREADS 3/4"	126-127
U221	EARTH ROD COPPER 254µm L = 2m DIAM 17.2 - 2 THREADS 3/4"	126-127
U222	EARTH ROD COPPER 254µm L = 3m DIAM 17.2 - 2 THREADS 3/4"	126-127
U223	EARTH ROD COPPER 350µm L = 1m DIAM 17.2 - 2 THREADS 3/4"	126-127
U224	EARTH ROD COPPER 350µm L = 1.5m DIAM 17.2 - 2 THREADS 3/4"	126-127
U225	EARTH ROD COPPER 350µm L = 2m DIAM 17.2 - 2 THREADS 3/4"	126-127
U226	DRIVING SPIKE FOR ROD DIAM 17.2 THREADED	126-127
U227	DRIVING HEAD FOR ROD DIAM 17.2 THREADED	126-127
U228	SCREW FOR COUPLING FOR ROD DIAM 12.7 THREAD 9/16"	126-127
U229	SCREW FOR COUPLING FOR ROD DIAM 17.2 THREAD 3/4"	126-127
U250	FUSE CARTRIDGE NH1 63A 115mm	114-115
U251	FUSE CARTRIDGE NH1 80A 115mm	114-115
U252	FUSE CARTRIDGE NH1 100A 115mm	114-115
U253	FUSE CARTRIDGE NH1 125A 115mm	114-115
U254	FUSE CARTRIDGE NH1 160A 115mm	114-115
U255	FUSE CARTRIDGE NH1 200A 115mm	114-115
U256	FUSE CARTRIDGE NH1 250A 115mm	114-115
U257	FUSE CARTRIDGE NH2 125A 115mm	114-115
U258	FUSE CARTRIDGE NH2 200A 115mm	114-115
U259	FUSE CARTRIDGE NH2 250A 115mm	114-115
U260	FUSE CARTRIDGE NH2 315A 115mm	114-115
U261	FUSE CARTRIDGE NH2 400A 115mm	114-115
U351	WIRE-STRAINER (600KG)	228-229
U352	WIRE-STRAINER (800KG)	228-229
U353	WIRE-STRAINER (400KG)	228-229
U354	MECHANICAL WINCH 500	228-229

Code	Designation	Pages
U355	MECHANICAL WINCH 1 000	228-229
U356	OVERHEAD SWIVEL	230-231
U357	OVERHEAD PULLING GRIP SINGLE EYE	230-231
U358	OVERHEAD PULLING GRIP DOUBLE EYE	230-231
U434	GALVANISED LAG SCREW DIN 571 DIAMETER x LENGTH	76-77
U435	BOLTS BH	76-77
U437	FLAT WASHERS	76-77
U438	NUTS	76-77
U439	THREADED SHAFTS TF	76-77
U479	PIGTAIL BOLT BQC	74-75
U510	ANCHORING CLAMP WITH MOVABLE HANDLE (NUT) 2x10-25	68-69
U511	ANCHORING CLAMP WITH MOVABLE HANDLE (NUT) 4x10-25	68-69
U512	ANCHORING CLAMP WITH CLOSED HANDLE 2x16-35	68-69
U513	ANCHORING CLAMP WITH CLOSED HANDLE 4x16-35	68-69
U514	FULLY SUPPORTED ANCHORING CLAMP OPENED HANDLE 4x25-50 EC	68-69
U515	FULLY SUPPORTED ANCHORING CLAMP OPENED HANDLE 4x50-95 EC	68-69
U516	FULLY SUPPORTED ANCHORING CLAMP CLOSED HANDLE 4x35-70 EC	68-69
U517	FULLY SUPPORTED ANCHORING CLAMP CLOSED HANDLE 4x70-120 EC	68-69
U518	FULLY SUPPORTED SUSPENSION CLAMP 4x10-120	68-69
U520	BRACKET WITH HOOK DIAM 16 6 POLE TYPE	68-69
U521	BRACKET WITH HOOK DIAM 16 6 UNIVERSAL	68-69
U522	HOOK BOLT DIAM 16 -250	68-69
U523	HOOK BOLT DIAM 20 -250	68-69
U524	HOOK NUT DIAM 16	68-69
U525	HOOK NUT DIAM 20	68-69
U526	BRACKET WITH SUSPENSION HOOK DIAM 16 -1800 daN	68-69
U527	BRACKET WITH SUSPENSION HOOK DIAM 16 -2000 daN	68-69
U550	MECHANICAL TIGHTENING SLEEVE 2 SCREWS	168-169
U551	MECHANICAL TIGHTENING SLEEVE 4 SCREWS	168-169
U558	PARALLEL GROOVE JAW BARE AI	34-35
U559	PARALLEL GROOVE JAW BARE AI/Cu	34-35
U560	JUNCTION 1KV HEAT-SHRINKABLE CABLE 4 C	168-169
U580	EJAS 95 - 50/70-54	172-173
U581	EJAS 95 - 50/70-70N	172-173
U582	EJAS 95 - 50/150-70N	172-173
U583	EJAS 95 - 70/70-54	172-173
U584	EJAS 150 - 70/70-70N	172-173
U585	EJAS 150 - 70/150-70N	172-173
U586	EJAS 240 - 95/70-54	172-173
U587	EJAS 240 - 95/70-70N	172-173
U588	EJAS 240 - 95/150-70N	172-173
U591	PROTECTION PLATE ROLL (width 160mm)	182-183
U592	PROTECTION PLATE ROLL (width 180mm)	182-183

Commercial reference index

	Code	Designation	Pages
U	U593	PROTECTION PLATE ROLL (width 240mm)	182-183
	U594	PROTECTION PLATE ROLL (width 300mm)	182-183
	U605	CUTOUT CABINET 30A BIPOLAR	198-199
	U606	CUTOUT CABINET 30A TETRAPOLAR	198-199
	U607	CUTOUT CABINET 60A BIPOLAR	198-199
	U608	CUTOUT CABINET 60A TETRAPOLAR	198-199
	U610	FUSE CARTRIDGE 22x58 AD 15A	112-113
	U611	FUSE CARTRIDGE 22x58 AD 30A	112-113
	U612	FUSE CARTRIDGE 22x58 AD 45A	112-113
	U613	FUSE CARTRIDGE 22x58 AD 60A	112-113
	U614	FUSE CARTRIDGE 22x58 AD 90A	112-113
	U615	FUSE CARTRIDGE 14x51 AD 15A	112-113
	U616	FUSE CARTRIDGE 14x51 AD 30A	112-113
	U617	FUSE CARTRIDGE 14x51 AD 45A	112-113
	U620	NEUTRAL TUBE 10.3x38	112-113
	U621	NEUTRAL TUBE 14x51	112-113
	U622	NEUTRAL TUBE 22x58	112-113
	U623	FUSE CARTRIDGE 10.3x38 AD 15A	112-113
	U635	INTEGRATED MODULAR BOX - 8 MODULES	196-197
	U636	INTEGRATED MODULAR BOX - 12 MODULES	196-197
	U637	INTEGRATED MODULAR BOX - 24 MODULES (12x2)	196-197
	U638	INTEGRATED MODULAR BOX - 36 MODULES (12x3)	196-197
	U640	FUSE CARTRIDGE 22x58 gG 2A	110-111
	U641	FUSE CARTRIDGE 22x58 gG 4A	110-111
	U642	FUSE CARTRIDGE 22x58 gG 6A	110-111
	U643	FUSE CARTRIDGE 22x58 gG 8A	110-111
	U644	FUSE CARTRIDGE 22x58 gG 10A	110-111
	U645	FUSE CARTRIDGE 22x58 gG 12A	110-111
	U646	FUSE CARTRIDGE 22x58 gG 16A	110-111
	U647	FUSE CARTRIDGE 22x58 gG 20A	110-111
	U648	FUSE CARTRIDGE 22x58 gG 25A	110-111
	U649	FUSE CARTRIDGE 22x58 gG 32A	110-111
	U650	FUSE CARTRIDGE 22x58 gG 40A	110-111
U651	FUSE CARTRIDGE 22x58 gG 50A	110-111	
U652	FUSE CARTRIDGE 22x58 gG 63A	110-111	
U653	FUSE CARTRIDGE 22x58 gG 80A	110-111	
U654	FUSE CARTRIDGE 22x58 gG 100A	110-111	
U655	FUSE CARTRIDGE 22x58 gG 125A	110-111	
U660	FUSE CARTRIDGE 14x51	110-111	
U661	FUSE CARTRIDGE 10.3x38	110-111	

	Code	Designation	Pages
U	U704	STAINLESS STEEL TIE 4.6	72-73
	U705	STAINLESS STEEL TIE 7.9	72-73
	U744-6	TUBULAR LUG 10 ² -6	54-55
	U745-6	TUBULAR LUG 16 ² -6	54-55
	U746-10	TUBULAR LUG 25 ² -10	54-55
	U747-10	TUBULAR LUG 35 ² -8	54-55
	U747-12	TUBULAR LUG 35 ² -10	54-55
	U747-8	TUBULAR LUG 35 ² -12	54-55
	U748-10	TUBULAR LUG 50 ² -8	54-55
	U748-12	TUBULAR LUG 50 ² -10	54-55
	U748-8	TUBULAR LUG 50 ² -12	54-55
	U749-10	TUBULAR LUG 70 ² -8	54-55
	U749-12	TUBULAR LUG 70 ² -10	54-55
	U749-8	TUBULAR LUG 70 ² -12	54-55
	U750-10	TUBULAR LUG 95 ² -8	54-55
	U750-12	TUBULAR LUG 95 ² -10	54-55
	U750-8	TUBULAR LUG 95 ² -12	54-55
	U752-12	TUBULAR LUG 150 ² -12	54-55
	U752-14	TUBULAR LUG 150 ² -14	54-55
	U754-12	TUBULAR LUG 240 ² -12	54-55
	U754-14	TUBULAR LUG 240 ² -14	54-55
	U755-16	TUBULAR LUG 300 ² -16	54-55
	U810-1	UNIVERSAL PLIER L=165mm 1000V	234-235
	U810-10	PLIER FOR INSULATED TERMINALS	234-235
	U810-11	WATER PUMP PLIER	234-235
	U810-12	SET OF 3 PLIERS 1000V	234-235
	U810-2	UNIVERSAL PLIER L=180mm 1000V	234-235
	U810-3	UNIVERSAL PLIER L=200mm 1000V	234-235
	U810-4	UNIVERSAL PLIER L=210mm 1000V	234-235
	U810-5	PHONE PLIER 1000V	234-235
	U810-6	CURVED PHONE PLIER 1000V	234-235
	U810-7	DIAGONAL CUTTING PLIER 1000V	234-235
	U810-8	STRENGTHENED CUTTING PLIER 1000V	234-235
U810-9	STRIPPING PLIER 1000V	234-235	
U811-1	CABLE CUTTER 1000V	234-235	
U811-2	CABLE CUTTER WITH PAWL DIAM 32 1000V	234-235	
U811-3	CABLE CUTTER WITH PAWL DIAM 52 1000V	234-235	
U811-4	CABLE CUTTER WITH PAWL DIAM 70 1000V	234-235	
U811-5	BIG BREACH SCISSORS 1000V	234-235	
U811-6	ANGLED KNIFE 1000V	234-235	
U811-7	CUTTING PLIER FOR PLASTIC SADDLES	234-235	
U811-8	PLASTIC PIPE CUTTER 1000V	234-235	
U812-1	ELECTRICIAN SET 17 PCS 1000V	236-237	

Commercial reference index

	Code	Designation	Pages
U	U812-2	ELECTRICIAN SET 26 PCS 1000V	236-237
	U812-3	ELECTRICIAN SET 37 PCS 1000V	236-237
	U812-4	ELECTRICIAN TOOLINGS SET 5 PCS 1000V	236-237
	U812-5	WRENCH SOCKETS SET 1/2" 1000V	236-237
	U813-1	DIGITAL MULTIMETER	236-237
	U813-2	CLAMP AMMETER	236-237
	U813-3	DIGITAL TESTER 220V	236-237
	U814-1	MONKEY WRENCH 10" 1000V	232-233
	U814-2	MONKEY WRENCH 12" 1000V	232-233
	U814-3	SET OF 10 SPHERICAL HEAD HEX KEYS	232-233
	U815-1	SET OF 6 SCREWDRIVERS 1000V	232-233
	U815-2	SET OF 6 SCREWDRIVERS	232-233
	U815-3	SET OF 7 SCREWDRIVERS TORX	232-233
	U820	INSULATING GLOVES CLASS 00 (500V)	216-217
	U821	INSULATING GLOVES CLASS 0 (1 000V)	216-217
	U822	INSULATING GLOVES CLASS 1 (7 500V)	216-217
	U823	INSULATING GLOVES CLASS 2 (17 000V)	216-217
	U824	INSULATING GLOVES CLASS 3 (26 500V)	216-217
	U825	INSULATING GLOVES CLASS 4 (36 000V)	216-217
	U826	HIGH SAFETY SHOES - DIELECTRICAL AND MECHANICAL PROTECTION	220-221
	U827	SHORT SAFETY SHOES - DIELECTRICAL AND MECHANICAL PROTECTION	220-221
	U828	HIGH SAFETY SHOES - MECHANICAL PROTECTION	220-221
	U829	SHORT SAFETY SHOES - MECHANICAL PROTECTION	220-221
	U830-1	BASIC HELMET	218-219
	U830-2	HELMET WITH TOOTH WHEEL	218-219
	U830-3	CHIN STRAP WITHOUT CHIN REST	218-219
	U830-4	CHIN STRAP WITH CHIN REST	218-219
	U831-1	PROTECTION GLASSES	218-219
	U831-2	PROTECTION GLASSES TINTED - UV FILTER	218-219
	U831-3	PROTECTION OVER GLASSES	218-219
	U831-4	PROTECTION MASK	218-219
	U831-5	FACE SHIELD - IMPACT PROTECTION	218-219
	U831-6	FACE SHIELD - ELECTRIC ARC PROTECTION	218-219
	U832-1	FILTERING HALF MASK WITHOUT VALVE - FFP1	218-219
	U832-2	FILTERING HALF MASK WITH VALVE - FFP2	218-219
	U833-1	PROTECTIVE NITRILE GLOVES	216-217
	U833-2	PROTECTIVE LEATHER GLOVES	216-217
	U834-1	BASIC HARNESS KIT (HARNESS + TETHER + 2 CARABINERS + BAG)	222-223
	U834-2	HARNESS 1 ANCHORING POINT	222-223
	U834-3	HARNESS 2 ANCHORING POINT	222-223

U	U834-4	HARNESS 4 ANCHORING POINT	222-223
	U834-5	HARNESS 2 ANCHORING POINT - DIELECTRICAL	222-223
	U834-6	WAIST HARNESS	222-223
	U835-1	WORK POSITIONNING BELT	222-223
	U835-2	WORK POSITIONNING BELT (BELT + ROPE + CARABINER)	222-223
	U836-1	POLYAMIDE ROPE - 10 METERS	222-223
	U836-2	POLYAMIDE ROPE - 20 METERS	222-223
	U836-3	GUIDED TYPE FALL ARRESTERS	222-223
	U836-4	CARABINER	222-223
	U837-1	Y TETHER WITH CARABINERS AND ENERGY ABSORBER	222-223
	U837-2	SIMPLE TETHER WITH CARABINERS AND ENERGY ABSORBER	222-223
	U837-3	SIMPLE TETHER WITH CARABINERS AND ENERGY ABSORBER - DIELECTRICAL	222-223
	U837-4	Y TETHER WITH CARABINERS	222-223
	U837-5	SIMPLE TETHER WITH CARABINERS	222-223
	U837-6	SIMPLE TETHER	222-223
	U837-7	SIMPLE ADJUSTABLE TETHER	222-223
	U837-8	SIMPLE ADJUSTABLE TETHER WITH CARABINERS - DIELECTRICAL	222-223
	U838-1	TIE-OFF	222-223
	U838-2	TIE-OFF - DIELECTRICAL	222-223
	U838-3	ANCHORING POINT	222-223
	U838-4	HANGING RING	222-223
	U839-1	SIMPLE TOOL BELT	236-237
	U839-2	DOUBLE TOOL BELT	236-237
	U840	INSULATING MAT	224-225
	U841	INSULATING LADDER	224-225



Creator of electrical equipment



Discover our Web Site
and make your own
customized catalogue !

International expert in electrical distribution, **Michaud Export** designs, develops and implements reliable systems reducing maintenance operations on distribution networks.

As the architect of your solution, the company focuses on on-going innovation and leverages on the worldwide renowned expertise of the 250 employees at **Michaud Group**, leader in the industry for systems and connection fittings for electrical installations.

Michaud Export

499, Rue du Revermont

ZAC La Cambuse

01440 Viriat

France

Tel +33 (0)9 70 75 50 24

contact@michaud-export.com

www.michaud-export.com



Implementation

These products must be implemented and used in **compliance with the applicable regulations** with a skilled, qualified professional undertaking to do so following the generally accepted rules of the trade.

For **live-line** implementation or handling, the electrician must comply with the requirements for live-line work conditions and must be equipped with the necessary personal protection equipment. The implementation temperature limits are: -10°C to +40°C.

Live-line work is carried out under the responsibility of the ordering customer in compliance with the applicable rules.

Before powering up the equipment, all the required verifications must be carried out.

Tools

The product should be installed and used with **suitable tools**.

The screw heads should be tightened with the appropriate tool: **Spanner** for hexagonal cap screws, **flat screwdriver** for slotted screw heads of the right size, **Phillips screwdriver** for cruciform screw heads, **HSHC screw head (awls)** for hollow hexagonal screw heads, etc. The screw heads with no torque-limiting device must be tightened to the recommended torque and must not be tightened again.

For further information:
www.michaud-export.com



Recommendations for use

The installation instructions must be read carefully before using the product.

The product must be used and implemented in compliance with these recommendations for use and installation instructions. It must be used for the applications for which it was defined by the operator/manager of the network and on an electrical installation that is compliant and compatible with the product.

Never exceed the capacities indicated on the device and in the instructions sheet.

Unless explicitly indicated, products are designed for no-load connection.



Environment

Please group your waste together and follow the recycling and destruction instructions before leaving the worksite.

1. APPLICATION OF CONDITIONS:

Purchaser make himself acquainted with these general selling conditions which shall lay down the Parties law, except purchaser's written denunciation ratified by MICHAUD EXPORT and despite opposite clauses that could be included in the purchaser's general conditions. Possible renunciation of one or few clauses herein does not interfere with the validity of the other clauses.

Except any formal and express derogation made by MICHAUD EXPORT, all purchaser's orders carry off his full and entire consent to the present General Selling Conditions which prevail over any Purchasing Conditions. All particular purchasing clauses or conditions aiming to modify the present conditions must not be contrary to the seller's ones.

2. ORDER:

Any order shall not constitute a contract unless accepted in writing by MICHAUD EXPORT.

3. PRICE LIST:

3.1 Unless otherwise stated by MICHAUD EXPORT, price lists and commercial offers are established in Euro €, excluding any other currency, even Euro indexed currencies, and is governed by Incoterms 2010 to be defined with the purchaser in the particular conditions.

3.2 The price list is established for standard items with specific given technical characteristics. Any technical changes on products to adapt them to other specifications or standards may lead to extra unit costs and price revision.

3.3 Unless otherwise stated by MICHAUD EXPORT, MICHAUD EXPORT reserves the right to gather purchaser's orders and to deal with according to a minimum invoice amount of 800 € excluding tax and freight charges (according to general price list in due force on the order date). Any order which amount is lower than 1 500 € shall result in the invoicing of a fixed sum of 150 € meant to cover administrative fees.

3.4 Unless otherwise stated and written by MICHAUD EXPORT, validity of the price list is one month starting when given to the purchaser.

3.5 The price list is subject to alteration without notice.

4. DELIVERY TIME:

4.1 The delivery time is defined as the case may be according to the commercial relationships established with the purchaser. MICHAUD EXPORT use their best endeavours to deliver the goods by the time fixed for delivery, however, in case of delay, they will not be responsible for any loss or damage thereby caused to the purchaser unless expressly accepted in writing by MICHAUD EXPORT.

4.2 Should partial or delayed deliveries occur, it does not justify any cancellation of purchaser's orders, and MICHAUD EXPORT shall not be liable and responsible for any actual or potential, direct or indirect, or consequential damages caused to the purchaser through delay or by failing on deliveries.

5. DISPATCH:

5.1 MICHAUD EXPORT use their best endeavours to select appropriate method of delivery with no responsibility on it. Choice shall be made freely unless purchaser's contrary notice who then support following additional cost that may follow.

5.2 Ex-works delivery is considered as an effective delivery, notably regarding modalities and payment terms.

5.3 Partial loss or damage during in transit must be reported to the carrier and to MICHAUD EXPORT in writing by registered letter with proof of delivery within three days after receipt of the goods by the purchaser. If these conditions are not complied with, the purchaser will be responsible for any loss or damage that may occur during transit.

The purchaser commits to return to MICHAUD EXPORT at his own costs and risks the products he rejected during his check-up for due investigation. The purchaser agrees that MICHAUD EXPORT shall return the products at the purchaser's cost and risks after examination or any possible repair or replacement.

6. USE OF THE PRODUCTS:

The purchaser has to follow imperatively the laws, current prescriptions in due force and custom rules regarding instruction procedures and use of the products. MICHAUD EXPORT shall not be responsible in case of wrong use of the products according to the specifications and prescriptions of use advised by MICHAUD EXPORT.

7. TESTING AND INSPECTION:

When testing and/or inspection is required by the purchaser, tests shall be carried out at MICHAUD SA's facilities, and relevant costs shall be covered by the purchaser, unless any exemption agreed and approved by MICHAUD EXPORT.

8. WARRANTY:

8.1 MICHAUD EXPORT guarantees the purchaser against latent defect of the goods according to the conditions driven by the law. Once a guaranteed shortcoming is stated by the buyer, it is up to him to send his reclamation to MICHAUD EXPORT with a registered letter with proof of delivery within a time limit of three months starting from the fault's appearance. This reclamation has to be accompanied by a detailed description of the fault's nature.

After this period of time the goods delivered shall be deemed as in good condition and the purchaser is no longer entitled to make a complaint about any defect on the products.

8.2 MICHAUD EXPORT guarantees its products for a period of one year after delivery or shifting from our facilities.

In case of fault, defect, non-conformity proved or admitted by MICHAUD EXPORT, MICHAUD EXPORT undertakes to replace the products admitted defective in reasonable time. In order to be replaced, rejected products shall be returned. No other prejudice of damage shall be required by the purchaser.

8.3 The guarantee is excluding the followings:

- If the product has been repaired or modified by the buyer or by third parties chosen by him ; or
- If it concerns items that have been made by sub-contractors or MICHAUD EXPORT

suppliers to whom the normal producer or Subcontractor guaranty applies ; or
- If the defect is coming from the buyer's negligence, or recklessness ; or
- If the defect is the result of a force majeure or of an external event.

9. TAKING BACK OF THE PRODUCTS:

In case the purchaser renounces to the ordered and delivered products, no taking back will be considered unless expressly accepted in writing by MICHAUD EXPORT. Rejected goods shall be sent back to the French plant defined by MICHAUD EXPORT. Credit of the sent back goods will be registered after receipt in the warehouse. Taking back value will systematically take into consideration a reduction to be defined for administrative and check-up cost as well as a reduction for restoration of the product and packaging if necessary.

10. PAYMENT:

10.1 Payment terms are defined with the purchaser in the particular conditions. All goods shall be paid to the MICHAUD EXPORT head office located in Viriat France whatever the payment terms used. Invoice date shall be the starting point of the settlement period.

10.2 Legal property transfer of the goods shall be retained until full payment of the whole sold goods. MICHAUD EXPORT keep the property of the goods until full payment of their price, sending bank drafts or any other bond notes building payment obligation not constituting a payment.

10.3 Any unpaid draft or invoice being at maturity will produce due interest, without giving notice. Applicable penalties shall be equivalent to three times the legal interest rate at the payment date located on the invoice. Payment of any other sums owed by the failing debtor shall be immediately payable, even if they are accepted draft. Any full or partial non-execution by the Customer of the payment obligations or any delay in payment shall, without prejudice to any damages and interests, lead to the payment of fees of 40 € for collection charges set down by decret made pursuant to the section 121 of this act. Moreover, MICHAUD EXPORT keep the right, in that case, to suspend or cancel fulfilment of the contracts and pending orders and demand cash in advance payment of any other delivery, whatsoever past conditions agreed for such delivery.

10.4 Any change in the purchaser situation regarding sale or other party's investment in the business, decease, incompetence, suspension of payment, official recovery, official receivership, temporary proceedings suspension, dissolution or form modification, even after partial fulfilment of the contracts or pending orders entails application of the same conditions as the ones described in case of unpaid invoice.

11. FORCE MAJEURE:

Neither MICHAUD EXPORT nor the buyer can be held responsible for a possible delay or lack in their obligations' execution, if this delay or lack is the result of a force majeure. A force majeure exists notably in the following situations, if they present certain characteristics of a force majeure, this means if the event was irresistible, unforeseeable, and externally provoked. This non-exhaustive list enumerates some situations which constitute a force majeure: explosions, fires, incidents, destruction of machinery, factories and equipment, natural disasters, acts by governmental authorities (refusing or cancellation of a license ...), wars, or any acts of war, flooding, riots, or social conflicts.

The party that faces such a circumstance which responds to the above given definition must immediately inform in writing the other party of this intervention and when this circumstance possibly ends. In the case of absence of information, the concerned party can not prevail over, unless in the case of intervening circumstances, which also prevent any communication.

Where a force majeure case which responds to the above definition intervenes, the time for the contract's execution is prolonged for a period of time corresponding to the event's duration. This does not include any payment of damages and interest or a penalty for the delay.

However if the above mentioned circumstances do persist for a period of time of 6 months, each party can cancel the contract without any payment of damages and interest.

12. CANCELLATION:

The contract is cancelled by law, without the need of any judicial formality where there are serious shortcomings by one of the parties concerning essential obligations. Cancellation would become effective within one month after the mailing of a registered letter with proof of delivery of an earlier made formal notice which stayed unfruitful.

The essential obligations, which the parties have to fulfill, notably consist of the due payment by the buyer or the merchandise's non-delivery by MICHAUD EXPORT. In case of a serious shortcoming to the contract's essential obligations, the sale will be cancelled in good law without prejudice of damages and interest that can be claimed.

Any tolerance that one party allows the other not to prevail immediately over one of its rights, will not prejudice the party's rights to prevail over them later, except in case of a contrary convention or stipulation to the present conditions.

13. JURISDICTION ATTRIBUTION:

These General Selling Conditions shall be ruled and governed by the French Law as followed by the courts. Any dispute deriving from these General Selling Conditions, after failure of a previous conciliation procedure shall be of the exclusive French jurisdiction of the competent Commercial Court of Lyon located in France. Each party accepts to bear any costs and expenses it would have exposed.

14. OFFICIAL LANGUAGE:

The French version of these general selling conditions, available upon enquiry, is the only legally acceptable version.